

WISH YOU EVERY SUCCESS WITH YOUR NEW DRUM KIT...

This leaflet is intended as a guide to assembling, tuning and positioning your Drum Kit.

HOW TO ASSEMBLE THE DRUM KIT

1 Put to one side all the cymbals. (If included with the Drum Kit).

Fig.1a

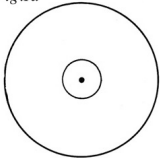

BOTTOM
HI-HAT CYMBAL

Fig.1b

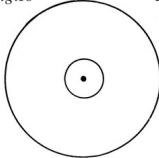

TOP
HI-HAT CYMBAL

Fig.1c

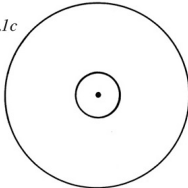

CYMBAL

2 Put to one side the already assembled Snare Drum.

Fig.2

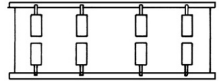

SNARE DRUM

3 Put to one side all the Drums that are unassembled.

Fig.3a

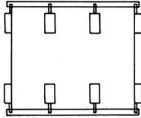

SMALL HANGING TOM TOM

Fig.3b

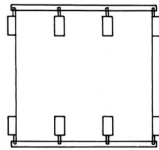

LARGE HANGING TOM TOM

Fig.3c

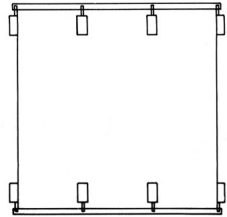

FLOOR TOM TOM

4 Put to one side the Bass Drum Pedal, Beater, Spring & Hook.

Fig.4a

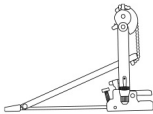

BASS DRUM PEDAL

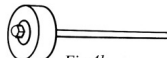

Fig.4b

BASS DRUM BEATER



Fig.4c

SPRING



Fig.4d

HOOK

5 Put to one side the Snare Drum Stand, Hi-Hat Stand, Cymbal Boom Stand and the Drum Stool. (If included with the drum kit).

Fig.5a



SNARE DRUM STAND

Fig.5b



HI-HAT STAND

Fig.5c

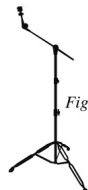

CYMBAL BOOM STAND

Fig.5d

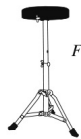

DRUM STOOL

- 6** Put to one side the box(es) containing all the small parts. This/these box(es) contain items such as shown in the following illustrations (All kits do not necessarily have all these parts).

HANGING TOM TOM HOLDER POST(S)

This/these post(s) will eventually enable you to fit the Tom Tom(s) to the Bass Drum. (Some kits have just one post).

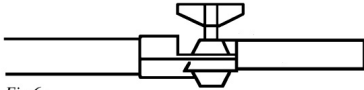

Fig.6a

3 x FLOOR TOM TOM LEGS

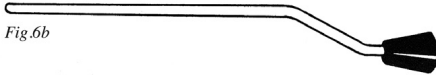

Fig.6b

2 x BASS DRUM LEGS (SPURS)

These will eventually enable the Bass Drum to stay upright. (Bass Drum Spurs may already be attached to the Bass Drum).

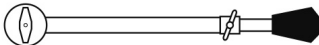

Fig.6c

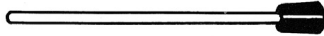

Fig.6d

Also put to one side the Drum Heads (skins), Bass Drum Hoops, Floor Tom Tom Heads & Hanging Tom Tom Heads (if unassembled).



Fig.6k

2 x 22" BASS DRUM HEADS

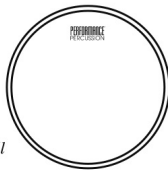

Fig.6l

2 x 16" FLOOR TOM TOM HEADS



Fig.6m

2 x 13" TOM TOM HEADS



Fig.6n

2 x 12" TOM TOM HEADS

BASS DRUM TENSION RODS
Tension Rods will come in full or mixed sets of either style, 6e or 6f.



Fig.6e

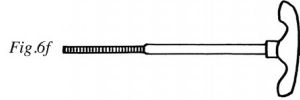

Fig.6f

BASS DRUM TENSION ROD BRACKETS

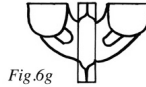

Fig.6g

TOM TOM TENSION RODS



Fig.6h

1 x PAIR OF DRUM STICKS

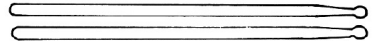

Fig.6i

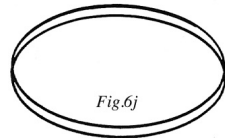

Fig.6j

2 x BASS DRUM HOOPS

- 7** Now take the Bass Drum (largest Drum) and position one Bass Drum Head (fig. 6k) on to the Drum. Place the Bass Drum Hoop (fig.6j) on top of the Drum Head. Insert the Bass Drum Tension Rods (fig.6e/6f) into the Bass Drum Tension Rod Brackets (fig.6g) and then clip the Brackets over the Hoop. Screw the Tension Rods into the Bass Drum Lugs.

DO NOT FULLY TIGHTEN. See 26 for tuning information.

To enable you to tighten the Tension Rods a Drum Key has been provided.

Now repeat on the other side of the Bass Drum.

NOTE: The edge of the Drum closest to the spurs is the front of the Bass Drum. The Drum Head with the Performance Percussion logo is the front head (Usually black with a white logo).

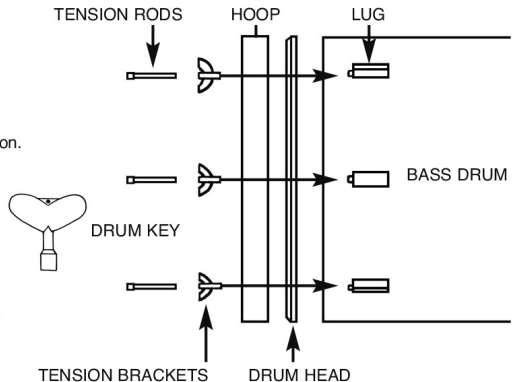

- 8** Now take the two Bass Drum Legs (fig.6c/6d) and fit these into the Bass Drum Leg Brackets. (These will keep the Bass Drum upright and stable).

(Some drum kits have the Bass Drum Legs (Spurs) pre-fitted).

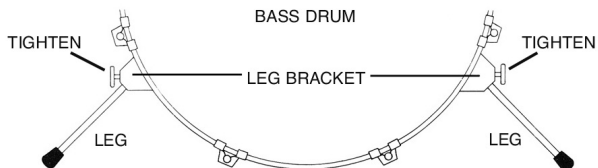

- 9** Now take the two 12" Tom Tom Heads (fig.6n) and fit them on to the Small Hanging Tom Tom (fig.3a), take the two 13" Heads (fig.6m) and fit them to the Large Hanging Tom Tom (fig.3b) using the Tom Tom Tension Rods (fig.6h).

DO NOT FULLY TIGHTEN.

NOTE: Tom Tom Hoops are sometimes attached to the Tom Tom Drums by 2 or 3 Tension Rods for transportation purposes only. Remove the hoops completely before fitting the Drum Heads.

To enable you to tighten the Tension Rods a Drum Key was provided.

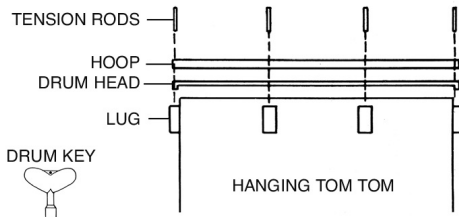

- 10** Now take the assembled Bass Drum and fit the Hanging Tom Tom Holder(s) (fig.6a) into the Holder bracket on top of the Bass Drum.

(Some drum kits only have one Tom Tom Holder Post)

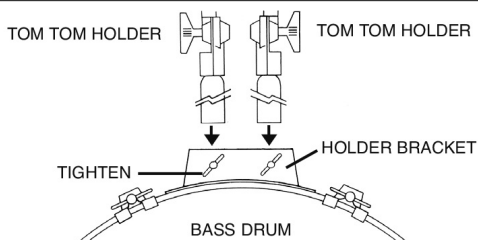

- 11** Now take the Hanging Tom Tom(s) (fig.3a & fig.3b) and attach these to the Hanging Tom Tom Holders or Holder and tighten the wingnut.

NOTE: Some Tom Toms may arrive without the Drum Heads fitted. If so, follow the instructions 9.

Some drum kits have slot-on holders. Slide on the Tom Tom(s) using the bracket(s) provided on the side of the drum(s).

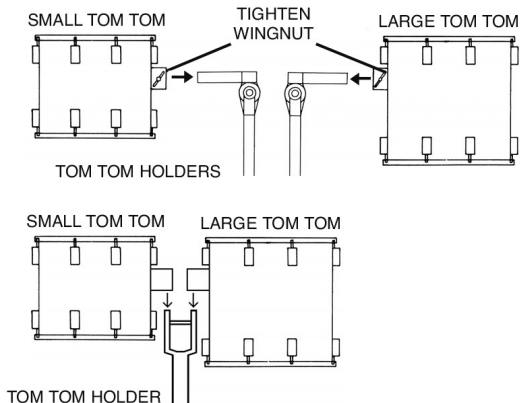

- 12** Now take the Hook (fig.4d) and fit it to the Spring (fig.4c).

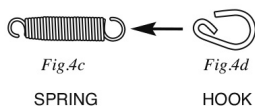

- 13** Now take the Spring & Hook and fit it to the Bass Drum Pedal (fig. 4a).

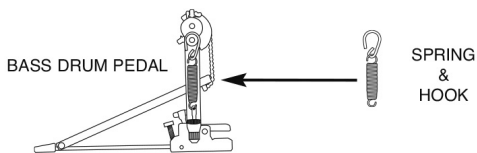

- 14** Now take the Bass Drum Pedal (fig.4a) and fit the Beater (fig.4b) into the Pedal. Now insert the Foot Pedal Rod(s) into the holes on the Bass Plate.

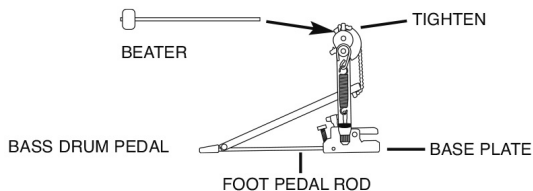

- 15** Now take the assembled Bass Drum Pedal and clamp it on to the rear Bass Drum Hoop.

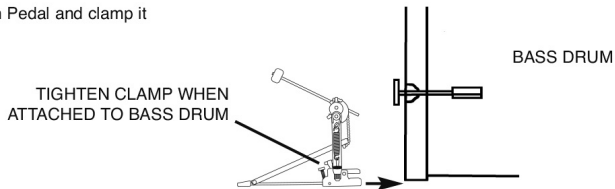

- 16** Now take the two Floor Tom Tom Heads (fig.6l) and fit them on to the Floor Tom Tom (fig.3c) using the Tom Tom Tension Rods (fig.6h). This procedure is the same as fitting the Hanging Tom Tom Heads therefore please see 9 and follow the instructions.

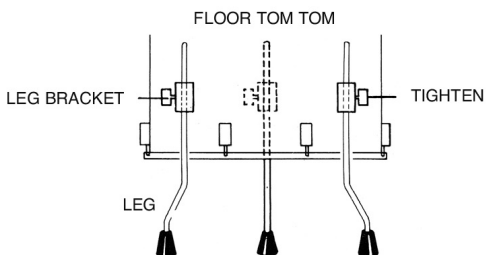

- 18** Now take the Snare Drum Stand (fig.5a) and assemble as per the illustration.

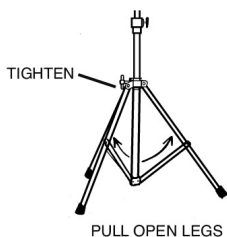

Place the Snare Drum (fig.2) on the basket and tighten so the Drum is held firmly.

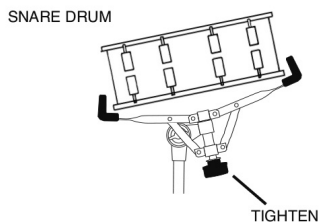
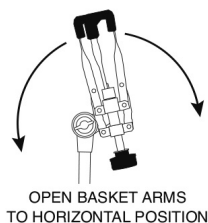

- 19** Now take the Cymbal Boom Stand (fig.5c) and assemble.

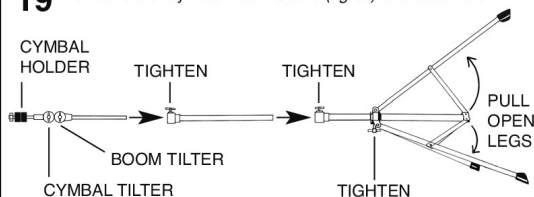

- 20** The Cymbal Boom Arm is sometimes located for transportation inside the top stem of the cymbal stand.

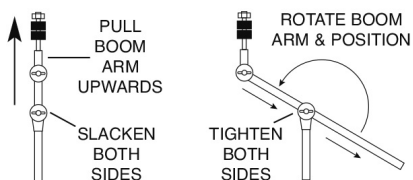

- 21** Take the Cymbal (*fig. 1c*) and put it on the Cymbal Boom Stand (*fig. 5c*).

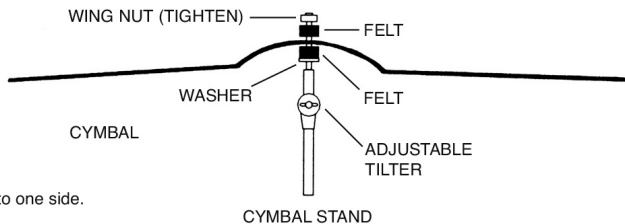

Place the assembled Cymbal Boom Stand to one side.

- 22** Now take the Hi-Hat Stand (*fig. 5b*) and assemble as per illustration.

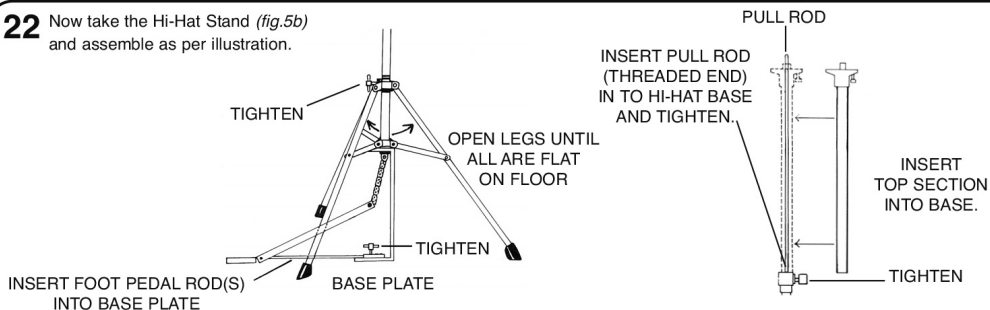

- 23** Now take the bottom Hi-Hat Cymbal (*fig. 1a*) and place on the Hi-Hat Stand

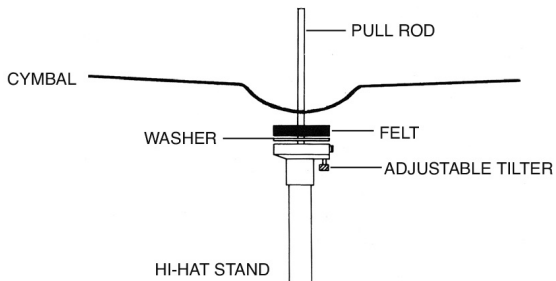

- 24** Now take the top Hi-Hat Cymbal (*fig. 1b*) and fit to the Hi-Hat Clutch, tightening the Bottom Nut.

Now fit the Hi-Hat Cymbal on to the Hi-Hat Pull Rod, tightening the Clutch to the Pull Rod.

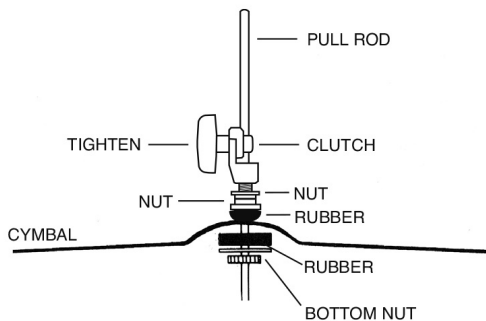

- 25** Now take the Drum Throne (*fig. 5d*) and assemble.

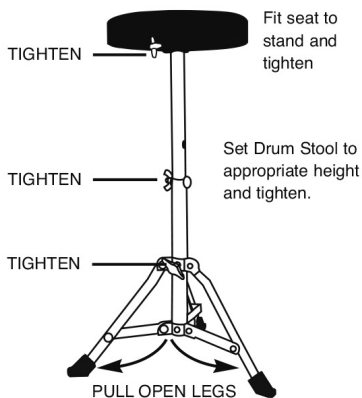

26 TUNING YOUR DRUMS

By now you will have already put all the Drum Heads on to each Drum. The next step is to tune each individual Drum in the following method.

THE METHOD OF TUNING. (except Snare Drum)

- 1 Tune your Drums in order of size. From the smallest to the largest (with the exception of the Snare Drum) so the pitch of each Drum gets lower as the Drum gets larger.
- 2 Tune the bottom head first. Tighten all the Tension Rods with your fingers until they begin to bite. Then take the Drum Tension Key and apply a three quarter turn to each Tension Rod in the following diametrical order:

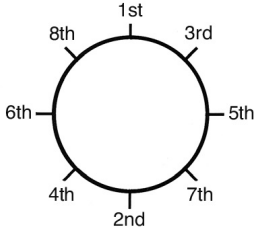

(This system works for any Drum with an even amount of Tension Rods)

Repeat the procedure until the Drum Head is fairly tight and in-tune. You can check this by tapping the Drum Head about an inch in from the hoop. If it is in-tune the note will remain the same all round the Drum.

- 3 Repeat No.1 for the top Drum Head. When the Drum is in-tune you will then be able to slightly lower or higher the pitch of the Drum by turning each Tension Rod a quarter of a turn.
- 4 The Snare Drum. This Drum is tuned in the same way as the other Drums, but with the Snare action lowered. When tuned, raise the snare action and adjust the snares tension across the bottom head by turning the fine tuning knob located above the snare action lever.

NOTE: If the top Drum Head is slack it will produce a dead, flat sound, while a tight head will sound crisp and bright.

If the bottom head is slack it will create less Snare buzz with a deeper tone. A tight bottom head produces a crisp, brittle sound.

27 Having now tuned the Drums place the Drum Kit in the following position for playing.

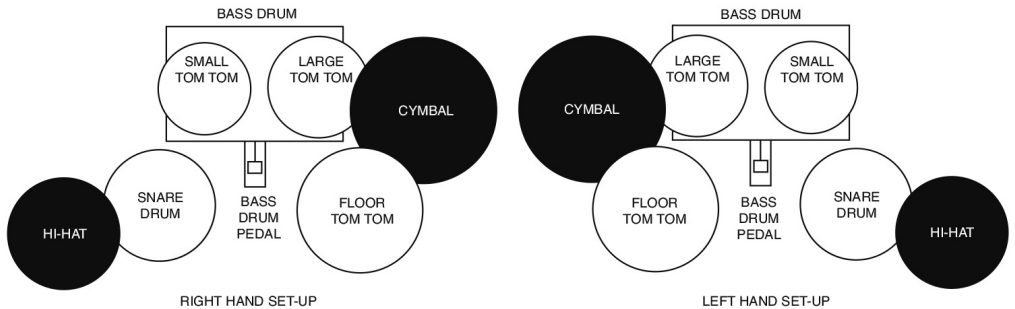

DRUM KIT HELPLINE: 0113 232 0082



Worldwide Trade Distributor
John Hornby Skewes & Co. Ltd.,
Salem House, Parkinson Approach, Garforth, Leeds LS25 2HR, U.K.
www.jhs.co.uk