

Mont Marte

Cross hatch a black cockatoo with fineliners



I can create

www.montmarte.net



© Mont Marte International Pty Ltd
ACN 101 589 897

Mont Marte

Materials List

MMPM0025 Mont Marte Graphic Fineliners Set 7pc

MSB0054 Mont Marte Sketch Pad 150gsm 25 sheet A3

From your studio:

6B and HB Pencils

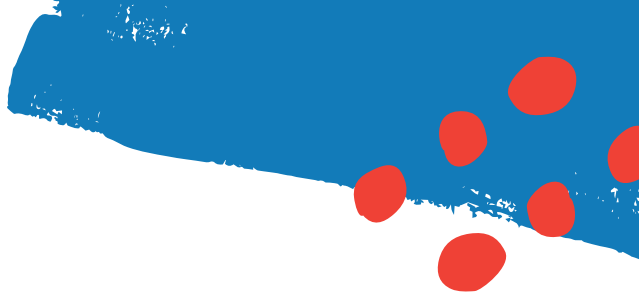

1

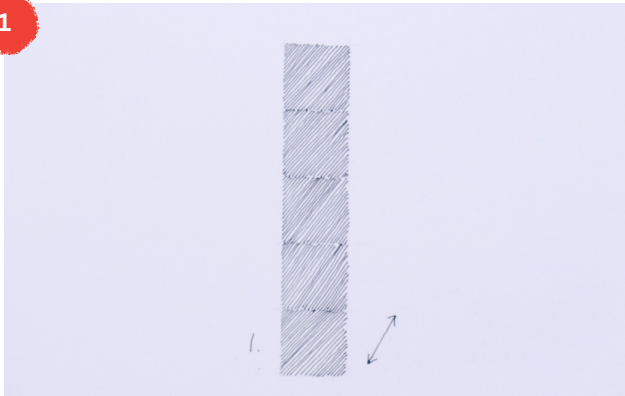

1. Creating a tonal scale for reference

Crosshatching is a technique that uses intersecting lines to create shadow.

This project uses 5 varying weights of tone.

The lightest tone is laid in with 45 degree lines.

The second tone can be laid in with vertical lines over the previous lines.

For the third tone, lay 45 degree lines in the other direction over the previous lines to create the third tone followed by horizontal lines.

The fourth tone is created by drawing lines at a 60 degree angle over the previous.

The fifth, darkest tone can be created by drawing the lines at an alternative 60 degrees over the top.

So lets get started!

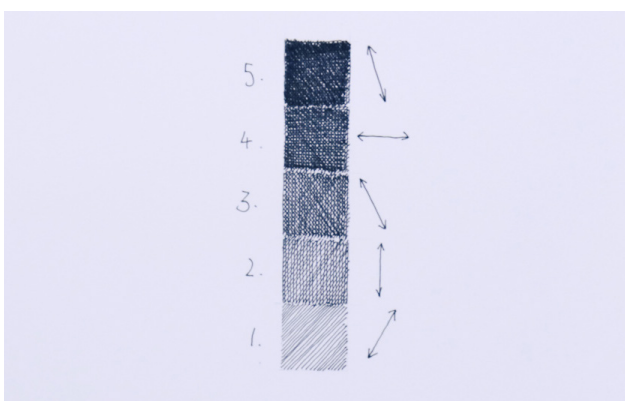
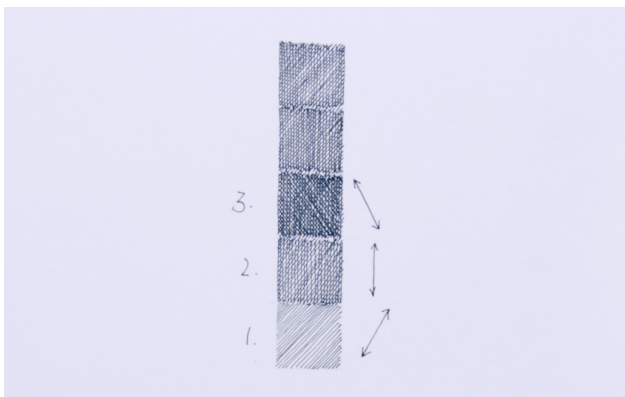



2



2. Transferring the outline

To transfer the outline, shade the back side of the supplied outline with a 6B pencil, flip it over, tape it onto a sheet of paper, and transfer the outline of the bird with a sharp 2H pencil. You can do this by tracing the outline of the bird.

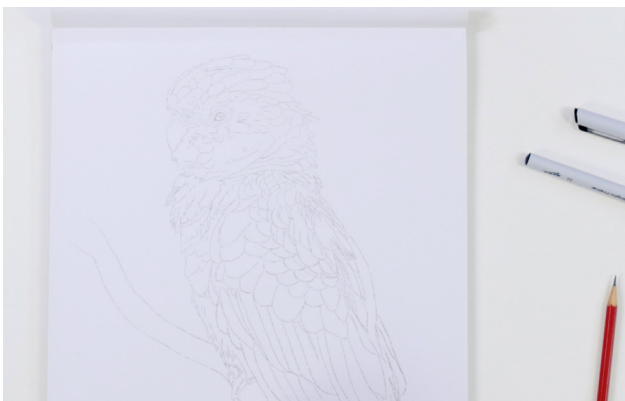

3

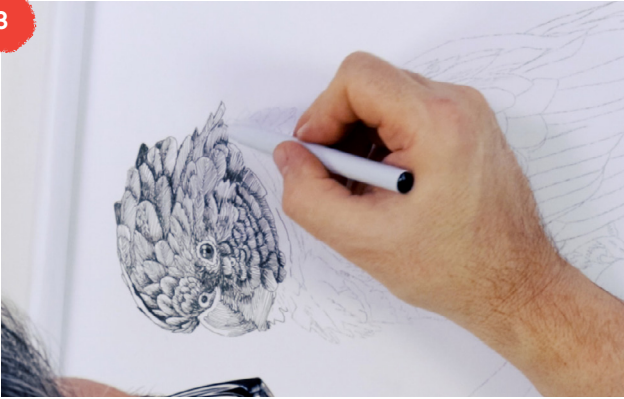

3. Shading the bird

The best way to start is from the head and move down the page. This way you can minimise the risk of smudging.

Draw the outline first and then fill the area in. Use the finished work as reference for what tone to draw where.

Use the 0.5 pen for most of the outlines and the finer 0.1 and 0.05 pens for the hatching. This allows precision with the lines.



Have fun and don't forget to #montmarteart to share your project with us!



