

Precision and productivity for the panel processing
Everything from a single source. Everything 100%!

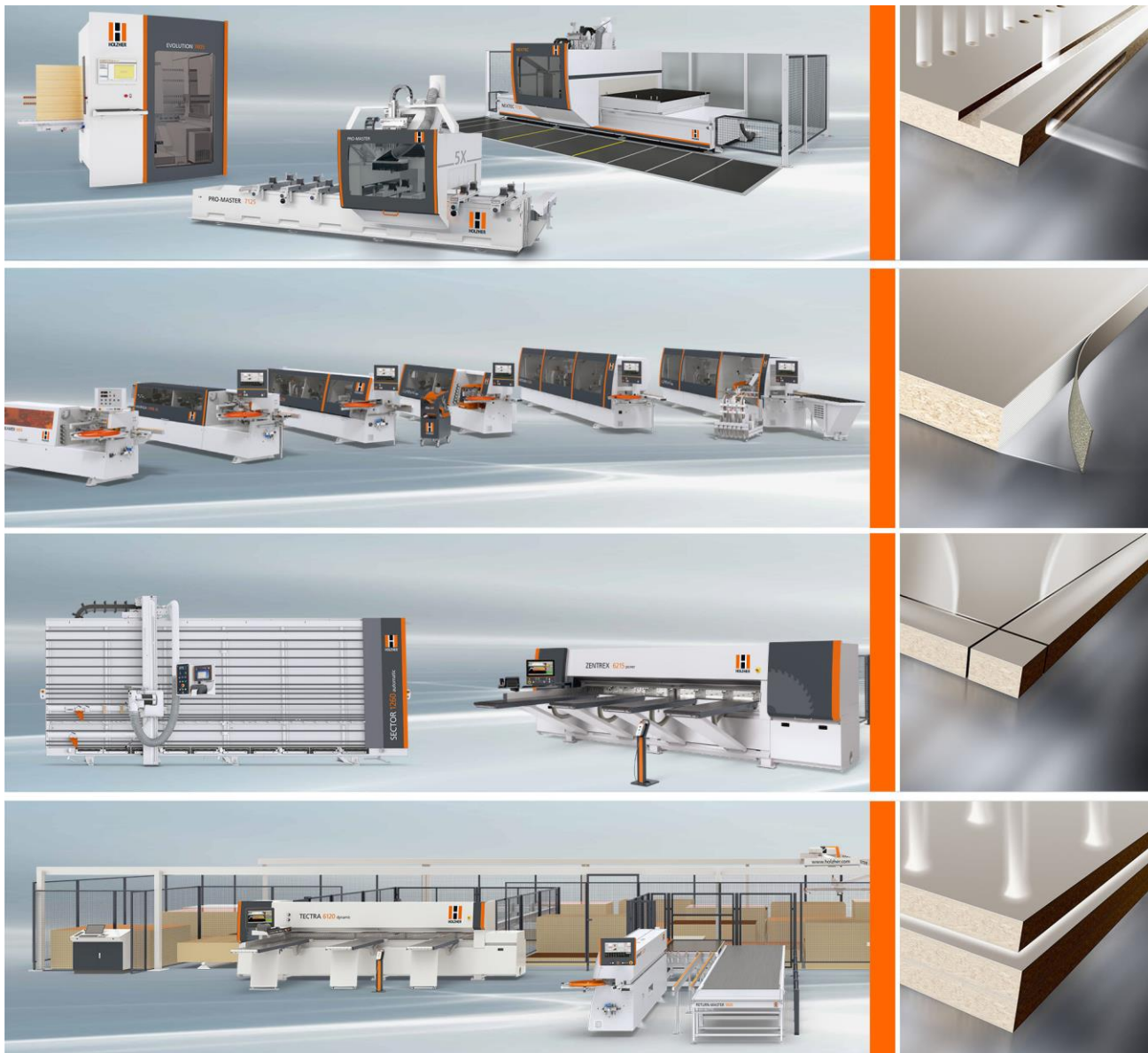

Proposal

HOLZ-HER Edgebander SPRINT 1327 PUR Door

(pictured with optional front hood)



Michael Weinig (UK) Limited

5 Blacklands Way, Abingdon Business Park, Abingdon, Oxon OX14 1DY. Tel: (01235) 557600

File:

Offer

Michael Weinig (UK) Ltd
Abingdon Business Park
Abingdon
OXON OX14 1DY
Tel: 01235 557 600
Fax: 01235 538 070

Date	23.02.2021	Mr Mark Howard Bailey
Our Ref	QH2562/CB/OK	Email
Contact	Aaron Hoyle - Calderbrook	Phone (Mob)
Mob	01706 873344	

Your benefit at a glance

SPRINT Series

user friendliness, productivity, accuracy and reliability for years due to torsion-free, welded machine base, conveyor chain with intelligent transport rail lubrication, pneumatic **lock at machine infeed for shortest workpiece distance**, electric pressure bridge adjustment, variable **feed rate 10 - 18 m/min.**

Controls and operation

With rotating and swiveling control panel, dust proof.
Comprehensive program memory, cpl. recording of all operational data, service messages in plain text. Fully automatic operation of processing units on **NC servo axes.**

Glu Jet hybrid technology

Highly flexible adhesive application by **patented nozzle technology** for **invisible glue lines.**
EVA and PUR adhesives are processed as standard without extensive and expensive additional equipment.
Glue processed in the form of cartridges and granules.
Neutral or colored glue is changed in an instant.
Lowest energy costs due to **short heat-up in 3 minutes.**
Automatic cleaning of the glue system at your fingertips.

Aggregat technology

Modern and solid processing units, continuously developed based on our 50 years of experience in edgebanding, ensure the high quality processing of your edges and ensure highest quality of the finished furniture.

Tool Technology

Diamond tipped milling tools, state of the art technology with an integrated chip disposal and patented Pro Lock keyless chuck, each matched to your application.

Accessories

The extensive range of accessories ranging from energy saving ECO mode to an electronically controlled spraying unit that eliminates unnecessary rework and cleaning. Upgrading of the accessories is easily accomplished thanks to the modular machine design.

Technical Specification

HOLZ-HER Edgebander SPRINT 1327 PUR Door
(pictured with optional front hood)



BASIC MACHINE

Base frame for highly rigid welded design
Stable pressure bridge with twin-row rubberized pressure rollers.
Surface hardened round steel guide with direct drive for adjusting pressure bridge

Motor-driven height adjustment for pressure bridge
Integrated control cabinet, easily accessible
Integrated chip collector box at end of machine

Rotating and tilting control panel located ergonomically at eye height
Roller-mounted pull-out workpiece support

Manual lubrication nipples for intelligent transport chain lubrication
Pneumatic locking roller for the minimum workpiece interval at machine entry
Light barrier for workpiece recognition

Machining area covered by large, space-saving, noise-insulated safety cover with large hood opening.
Powerful drive motor for shock-free transport of workpieces by workpiece chain
Transport chain runs on precision half-round flat guides, chain pads on transport chain with high lug for perfect grip on workpieces

KPT 1786308*

BASIC MACHINE SPRINT 1327 PUR Door
motorical pressure beam adjustment

MACHINE ELECTRICAL SYSTEM

*

Electric for variable feed 400 V / 50 Hz, 2.2 KW

TECHNICAL SPECIFICATIONS

SPRINT 1327 PUR Door (UK Edition)

Edgebander for edging and post-processing plate-shaped materials

Edging thickness coiled edging: 0,4 - 3 mm

Edging thickness of cut-length edging:

max. 15 mm

(cross section material depending)

Edge height: max. 65 mm

Workpiece thickness: 8 - 60 mm

Workpiece width: min. 60 mm

Workpiece length: min. 160 mm

Feed speed: variable 10 - 18 m/min.

MACHINE OPERATION

*



Edge Control 19

with 18.5" 16:9 color touchscreen

High performance controls for extremely simple machine operation for **efficient machine setup and conversion.**

Rotating and tilting control panel at eye level with Windows-like user interface, all information is displayed in plain text and/or graphics, with extensive program memory.

External USB interface



ECO MODE

This power-saving mode is an automatic **stand-by mode**, which puts all drives out of operation as soon as no workpiece is entered into the machine. The motors correspond to the new energy efficiency class IE 3. If a workpiece is not entered into the machine over a longer time period (6 minutes) the heater of the glue application system automatically shuts down. No more energy is consumed by the machine.

EQUIPMENT VARIANTS AND ACCESSORIES



Automatic lubrication of the transport chain

Intelligent automatic transport chain lubrication. Sensor-controlled unit, for metering lubricate to match load.



Infrared heater ZH701

The workpiece edge is warmed up before the adhesive application for a better adhesion.



iTronic - Adaptive pressure and glue quantity control
automatic, program controlled fine adjustment for optimum adjustment to edge thickness, edge materials and glue types which guarantees best process results.

Automatic package consists of:

- automatic glue quantity control
 - adaptive guillotine
 - automatic pressure section
- incl. monitoring of remaining glue quantity
incl. automatic PUR purge system



Second workpiece support incl. connection kit

connection kit: 502.8953
add. workpiece support for 1327/1375: 502.7875

INFEEED AREA



Infeed fence 1350 mm long

Extended infeed fence for exact feeding of very long workpieces to the pre-milling unit, simply adjustable for the regulation of the chip dropping during milling

PRE-MILLING UNIT

*



Pre-milling unit 1802 (2 x 2.0 kW, 200 Hz, 12000 min⁻¹)
with 2 cutter units for joining the panel edge
1x counter clockwise run, 1x clockwise run
max. joint thickness: 3 mm

Advantage AirStream Technology:

Low-noise operation in use and idling -3 dB(A)

Chip capture rate up to 99% through AirStream technology.
This means significantly less double cutting, longer tool life and less cleaning effort.

35° axis angle ensures excellent cutting quality.

Resharpener zone = 1.5 mm diamond,
up to 3 - 4 re-sharpenable (depending on material)

*

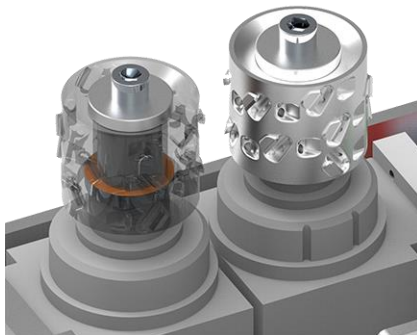

Diamond cutter Ø 70 x 64 x 30 mm, **2+2 teeth, left hand**
Air Stream System (HOLZ-HER / LEUCO patent)
For pre-milling unit **1802 / FG201**

*

Diamond cutter, dia. 70 x 64 x 30 mm, **2+2 teeth, right hand**
Air Stream System (HOLZ-HER / LEUCO Patent)
For pre-milling unit **1802 / FG201**

EDGE FEEDER

*

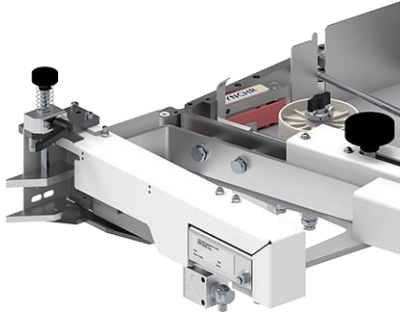

Edge feeder 1901 SYNCHRO

automatic transport of roll and strip products

max. load capacity: 150 mm

Synchronous drive with adjustable edge protrusion for cut length edging

for coils: max. edge thickness 3 mm (material dependent)

forward cut up to max. 65 mm (material dependent)

max cross section 135 mm² (material dependent)

support table for coils Ø 820 mm

GLUE APPLICATION

*

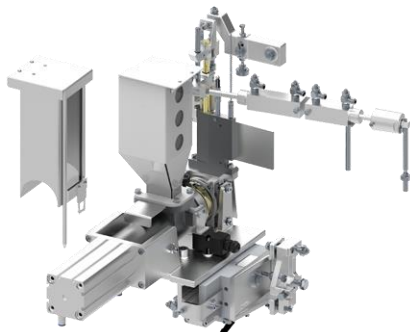

Glue application system Glu Jet GJ301 automatic

(2,3 kW, 50 Hz)

Automatic adjustment of gluing height (tracing nozzle)

Glu Jet hybrid technology

Processing of EVA and PUR adhesives

Adhesive in cartridge or granules form

Processing of neutral and coloured adhesives

Glue applied by means of nozzle technology

Heat-up time: 3 minutes

Incl. hopper for cartridges: 4 cartridges (approx. 1,4 kg)

Incl. hopper for glue granules: (approx. 1,5 kg)

Incl. automatic reloading of glue

Incl. automatic rinse function directly at the control panel through separate rinse channel

Automatic glue temperature reduction according to time



GLU JET rinse hopper
to collect glue residues during rinse procedure
incl. parting agent

PRESSURE UNIT

*



Pressure section DW501 MOT
first roller driven, 2 support pressure rollers
motorical with pneum. control of the pressure rollers
PLC-controlled adjustment of edge thickness via NC servo-drive

END TRIMMING UNIT

5058122 **End-trimming KA702 pneumatic**
 (2 x 0.75 kW, 200 Hz, 12,000 min⁻¹)
Pneumatic pivoting feature 0/10° for coils and strips:
 max. edge thickness: 20mm
 (depending on material and feed speed),
 hardened and precision-ground linear guides each, incl.
 2 noise reduced TC-sawblades altern. teeth, Ø 120 mm,
 Z 22, incl. 2 extraction hoods

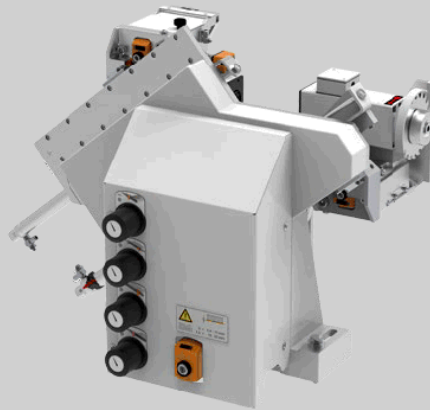

FLUSH TRIMMING

*



Trimming unit BF501 (2 x 1.1 kW, 200 Hz, 12,000 min⁻¹)
for flush trimming up to 15 mm thickness
 max. panel thickness: 60 mm, for flush trimming, HW-knives with
 CM-technology (System Leuco), Ø 70 mm,
Air Stream System,
 cutting width 16 mm, Z = 4, patented ProLock screw-in clamping
 system for rapid tool change, with integrated chip removal, incl.
 blow nozzles

FLUSH TRIMMING

*



Trimming unit BF501 (2 x 1.1 kW, 200 Hz, 12,000 min-1)
for flush trimming up to 15 mm thickness
 max. panel thickness: 60 mm, for flush trimming, HW-knives with CM-technology (System Leuco), Ø 70 mm,
Air Stream System,
 cutting width 16 mm, Z = 4, patented ProLock screw-in clamping system for rapid tool change, with integrated chip removal, incl. blow nozzles

GUARANTEE

Glu Jet - 3 year warranty

On all mechanical and electrical parts.
 Excluded are damages to the system due to improper operation and/or due to insufficient cleaning and maintenance. The extended warranty is limited to single shift work or a maximum workload of 200.000 meters /year.

****Attention when using certain adhesives****

During our regular long-term product monitoring and the associated product improvement measures, we have noticed the PUR adhesive **JOWTHERM- Reaktant types 608.00 and 608.01** can clog the Holz-Her gluing station.

This can lead to a complete malfunction of the system.

We therefore advise against using this adhesive.

The warranty may be invalidated if the use of this adhesive is proven. This applies to both the granulate and cartridge versions.

Additional

"Track Blowers"

HIAB Delivery

Weinig UK HIAB delivery and positioning service for all machines. A professional team of machine movers deliver the machine to your site on a craned vehicle. The machine is unloaded, removed from all transport packaging and positioned where required. This expert service includes insurance against damage of the machine and is able to be scheduled to meet your requirements.

Price**(VAT to be charged at the standard rate ruling)****Optional Items****EQUIPMENT VARIANTS AND ACCESSORIES**

LED-Lamps (3 pc) for the infeed area / post-processing area
Moderne LED technique with tempered, break-proof glass
including LED workpiece sequence display

£ 669.60

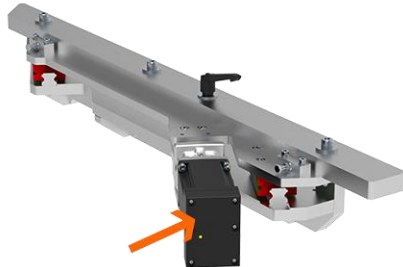
INFEEED AREA

Motorical adjustment of long infeed fence
automatically adjustable through the control panel
to adjust depth of cut

£ 897.45

AIR CUSHIONED TABLE

+



**Air cushioned table BS701 (230 V / 400 V, 50 Hz)
incl. long infeed fence**

£ 3,608.40

table with air cushions for an easy and gentle movement of the material at the infeed area of the machine

Fan control via control panel

length: 1800 mm, **width:** 600 mm
with height adjustable frame base for alignment to the infeed height of the machine (880 - 900 mm)

FLUSH TRIMMING

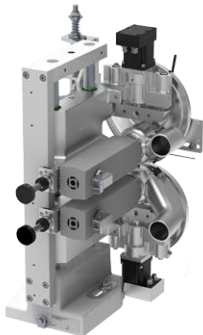

**Trimming unit BF501 MOT2 (2 x 1.1 kW, 200 Hz, 12,000 min-1)
motor-driven adjustment for vertical sensing rollers for cutting**

£ 883.50

extending longitudinal edges for flush trimming up to 15 mm thickness, max. panel thickness: 60 mm, HW-knives with CM-technology (system Leuco), Ø 70 mm,

Air Stream System,

cutting width 16 mm, Z = 4, patented ProLock screw-in clamping system for rapid tool change with integrated chip removal.

Payment Terms

Our standard payment terms are 20% of the agreed purchase price as a deposit with order and 80% of the agreed purchase price prior to delivery. Both payments will have to be sent electronically to the bank account of Michael Weinig (UK) Ltd on presentation of the invoices. Invoices will be required to be settled in the currency of the contract.

In the event of cancellation of an order after the equipment has been ordered from our supplier then Michael Weinig (UK) Ltd reserves the right to retain a proportion of the deposit paid to cover costs incurred.

Delivery Date

Currently this is approximately 12-14 weeks from placement of official order. Please note machines are not ordered on our suppliers until the deposit payment is received and therefore indicated delivery dates are only indications.

Validity of Offer

This offer is valid for 30 days from the date of the proposal.

Your Warranty

The warranty period for this machine begins on date of delivery and is 12 months for single shift operation, 6 months for two-shift operation and 3 months for more than 2 shifts.

The warranty terms are described in our terms and conditions for the supply of goods and services.

For the full text of our terms and conditions for the supply of goods and services please either request one from our office or visit our website www.weinig.co.uk.

Annex

Detailed description of machine control
Edge Control 19
18.5" touch screen with 16:9 format.
Network compatible.
LED display for equipment selection.
Program list with program names and numbers.
External USB port.

Individual selection of units with functions as basic setting options for desired values, path points and tool corrections as well as fixed path points.
Central and clear fine adjustment for unit set-up processes and axis settings (depending on equipment).
Interval display for minimum interval between workpieces.
Integrated path control - general or program-specific control of path points.

Clear and complete acquisition of all operating data.
Service reports in clear text.
Diagnostic system.
Integrated synchronous bus system for maximum unit control accuracy.

Individual user management for up to ten users, with password protection.
Barcode interface (optional).