

A heavy duty glasswasher, the Prime Line glasswasher ensures every glass is given a thorough cleaning thanks to a rinse arm configuration that reaches every point. No blind spots, no left over residue. No worries.

The PB34 features 4 wash cycles and durable double skinned stainless steel door.

STANDARD FEATURES

- Full stainless steel frame, tank and panels
- Colour coded status indicators - Green means Ready to start, Blue means cycle started, Red means alarm/check fault
- Soft start - cycle begins slowly to prevent glasses and crockery moving and possible breakage
- Digital temperature display
- Drain pump
- Adjustable feet supplied standard
- 1 piece deep drawn wash tank
- Inlet and waste hoses included
- Detergent dispenser & rinse aid dispenser
- Guaranteed rinse cycle only when water reaches set temperature
- Micro filter on wash pump which delivers better wash results
- Accessories include: 2 flatware racks, 1 insert for cup dishes and 1 cutlery container
- WRIS2+ Wash and Rinse Arm. Smart design delivers 25% reduction in rinse water consumption



DIMENSIONS

Dishwasher: 460W x 521D x 673H mm

Clearance: 270 mm

Rack size: 400mm x 400mm / 14" x 17"

WASH CYCLE

4 Cycles - Eco Fast (90 sec) / Glasses (90 sec) / Dishes (120 sec) / Intensive (240 seconds)

POWER SUPPLY

240 Volts, 15A single phase with plug

TECHNICAL DATA

Energy Consumption: 2.66 kW

Water Temp. Supply: 45°-55°C

Water Connection: 2-4 bar, 3/4"

Drainage: Hose provided 2m Long - Max drainage height 800mm

Water Consumption: 2.5L per cycle/rack

Noise: 61 dBA

Weight: 37 kg

Control Panel: Digital

SPECIFICATIONS ARE SUBJECT TO CHANGE WITHOUT NOTICE.

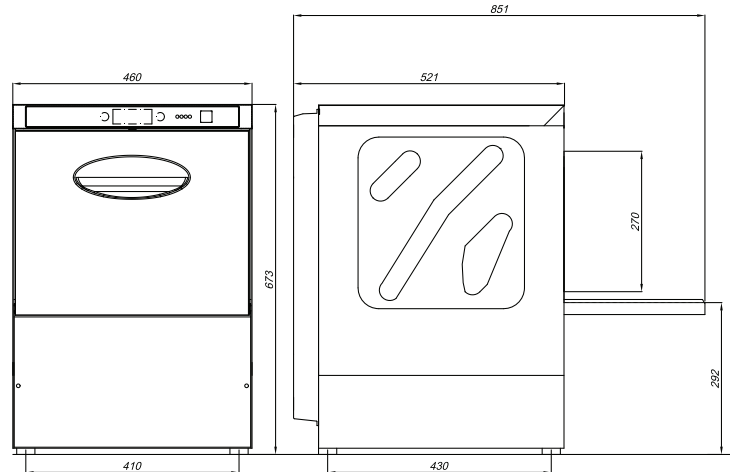

- A TANK DRAIN
- C ELECTRICAL CONNECTION
- D WATER INLET -2/4BAR 3/4"

