

LC1T

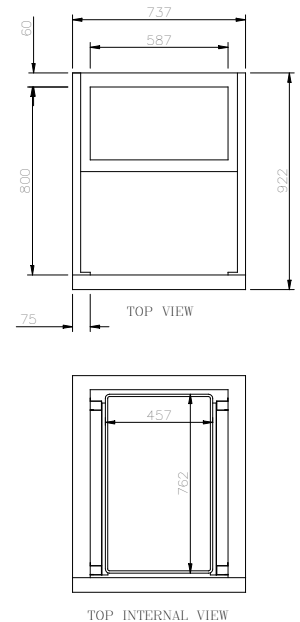

CATEGORY	FOODSERVICE UPRIGHTS
RANGE	Crystal
UNIT	FREEZER
TYPE	SELF CONTAINED
DOORS	1

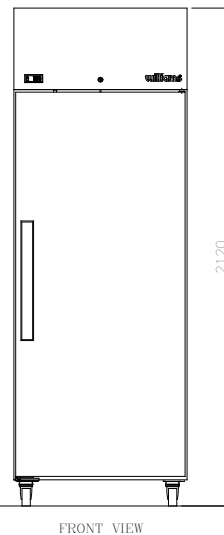
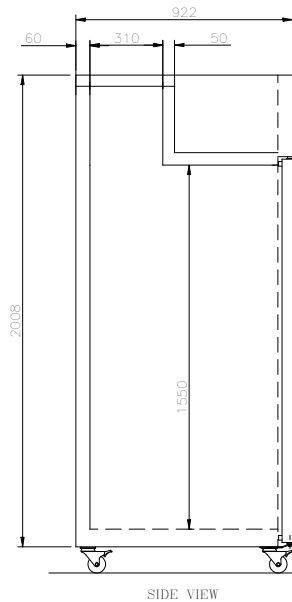

SPECIFICATIONS

CAPACITY LITRES	730
TEMPERATURE	-18°C / -22°C
DIMENSIONS - W X D X H (ON CASTORS) MM	737 W x 922 D x 2120 H
WEIGHT UNPACKED (KG)	160

STANDARD INCLUSIONS ***

DOOR TYPE	Standard: SD (Solid Door)
FINISH (INTERIOR & EXTERIOR EXCLUDING REAR & UNDER)	SS (Stainless Steel) CB (White)
TRAY SLIDES PER DOOR (NO TRAYS OR SHELVES SUPPLIED) (ACCOMMODATES 18" OR 16" TRAYS)	20

ELECTRICAL

POWER SUPPLY	10 amp	
FREEZER MODELS	RUNNING AMPS	4.5

GAS TYPE

REFRIGERANT	FREEZER MODELS	R404a
-------------	----------------	-------

REFRIGERATION WATTAGES FOR OPTIONAL REMOTE UNITS

FREEZER MODELS - SOLID DOORS	700 @ -30°C SST
------------------------------	-----------------

*** For **OPTIONS** refer to the current Williams Price Guide