



HOSHIZAKI

HFE-127B-AHD-ML

Pillarless Upright Freezer

PRODUCT FEATURES

- With no centre pillar you can use trays and containers of varying sizes.
- This Pillar Less range is perfect for kitchens looking to maximise their food storage.
- Standard with 8 shelves / 4 Split doors.
- Programmable electronic controller and display.
- 2 years parts and labour warranty.
- Comes standard with 4 x lockable (115 mm) castors (not legs).
- Optional Adjustable legs 150 - 180mm (Sold separately)

TECHNICAL DRAWING

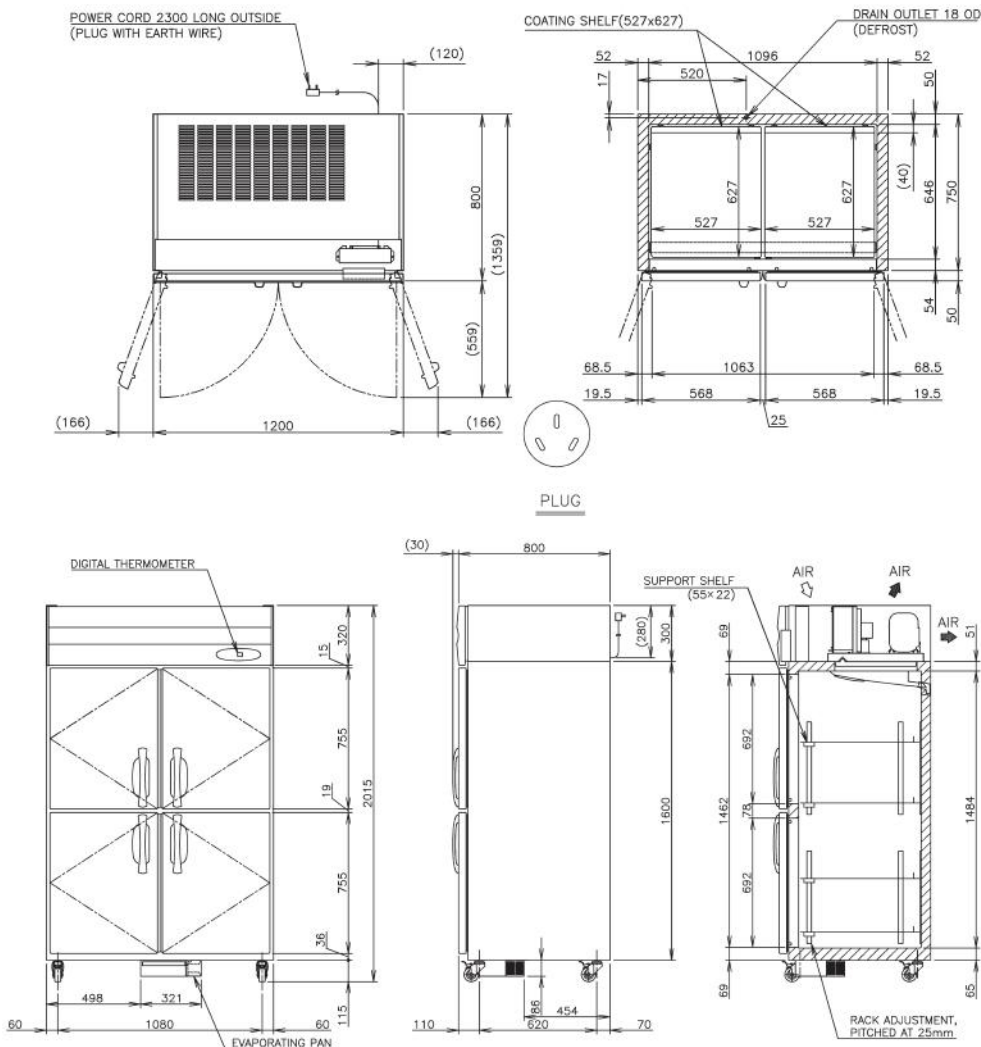

PRODUCT SPECIFICATION

Exterior	Stainless Steel, Galvanized Steel (Rear /Bottom)
Interior	Stainless Steel, ABS Plastic
Max Storage Capacity	1102L
Temperature Control	Microprocessor controlled Adjustable from -25 to -7°C
Evaporator	Fin & Tube type
Outside Dimensions	1200mm (W) x 800mm (D) x 2015mm (H)
Inside Dimensions:	1096mm (W) x 646mm (D) x 1484mm (H)
Refrigeration System	Forced Air Circulation
Weight Net/Gross (kg)	159 / 187
AC Supply Voltage	1 PHASE 220 - 240V 50Hz /10amp Plug
Amperage	Rated: 4.3A Starting: 20.0A
Refrigerant	R404A
Operating Conditions	Ambient Temp.: 5-43°C Voltage Range: Rated Voltage ±6%



Descriptions and specifications are subject to change at any time, without notice. Illustrations for demonstration purposes.

Copyright © 2020 Hoshizaki Lancer Pty Ltd. All right reserved. E&OE Date: Sept2020