

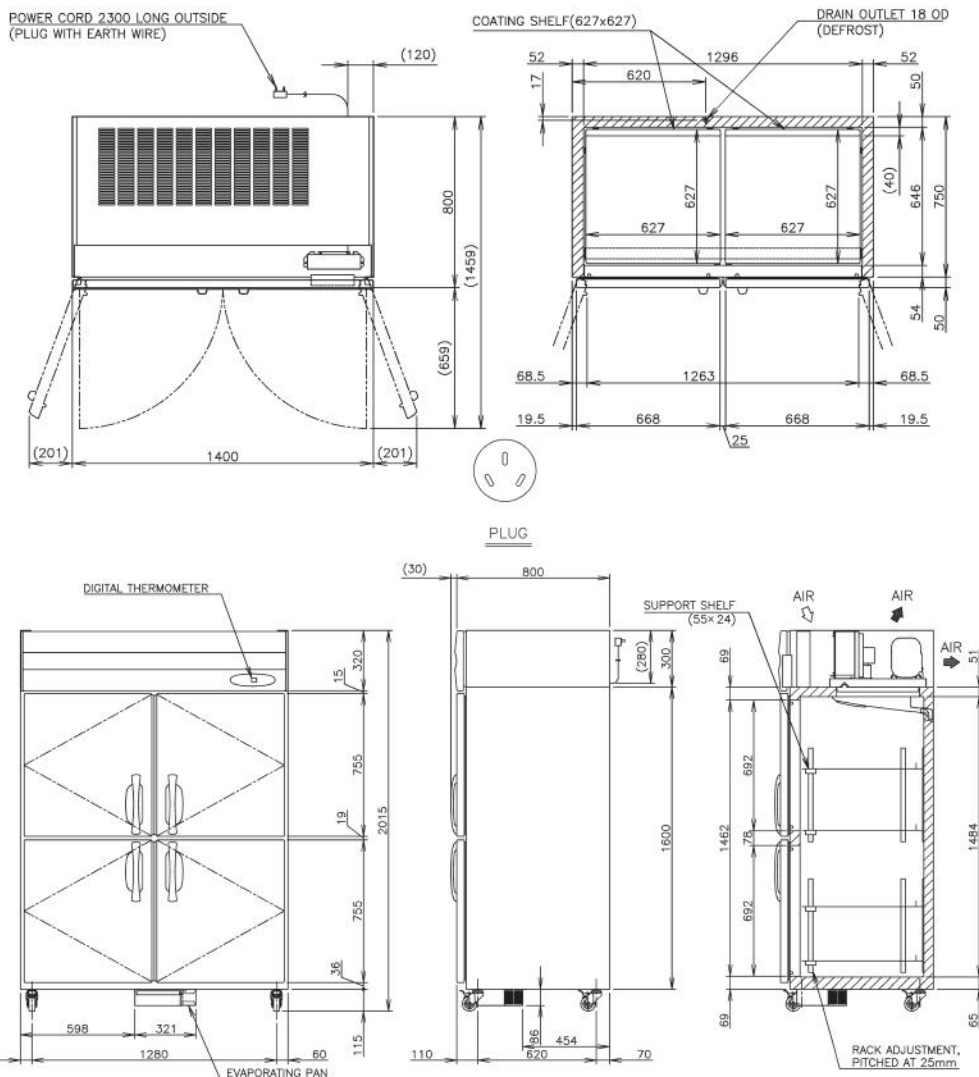

PRODUCT FEATURES

TECHNICAL DRAWING

- With no centre pillar you can use trays and containers of varying sizes.
- This Pillar Less range is perfect for kitchens looking to maximise their food storage.
- Standard with 8 shelves / 4 Split doors.
- Programmable electronic controller and display.
- 2 years parts and labour warranty.
- Comes standard with 4 x lockable (115 mm) castors (not legs).
- Optional Adjustable legs 150 - 180mm (Sold separately)



PRODUCT SPECIFICATION

Exterior	Stainless Steel, Galvanized Steel (Rear /Bottom)
Interior	Stainless Steel, ABS Plastic
Max Storage Capacity	1218L
Temperature Control	Microprocessor controlled Adjustable from -6 to 12°C
Evaporator	Fin & Tube type
Outside Dimensions	1400mm (W) x 800mm (D) x 2015mm (H)
Inside Dimensions	1296mm (W) x 646mm (D) x 1484mm (H)
Refrigeration System	Forced Air Circulation
Weight Net/Gross (kg)	167 / 202
AC Supply Voltage	1 PHASE 220 - 240V 50Hz /10amp Plug
Amperage	Rated: 4.0A Starting: 14.8A
Refrigerant	R404A
Operating Conditions	Ambient Temp.: 5-43°C Voltage Range: Rated Voltage ±6%



Descriptions and specifications are subject to change at any time, without notice. Illustrations for demonstration purposes.

Copyright © 2020 Hoshizaki Lancer Pty Ltd. All right reserved. E&OE Date: Sept 2020