

NECK FINISH: M24 SP415					HELIX < 2° 34'	
THREAD ROTATIONS: 3.0			T.P.I.: 8		CUTTER DIA: .375	
	"T"	"E"	"H"	"S"	"L"	"I"
MAXIMUM	.940	.856	.972	.061	.576	
MINIMUM	.924	.840	.942	.031	.546	.516
MEAN	.932	.848	.957	.046	.561	
OVERFLOW CAPACITY: 13.08 FL.OZ. (386.89ml)						

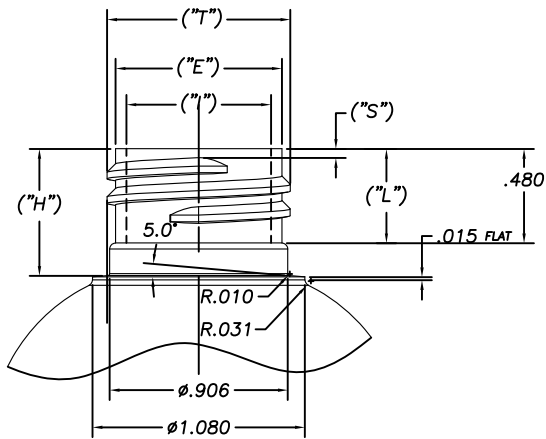

NECK FINISH: M24 SP410					HELIX < 2° 34'	
THREAD ROTATIONS: 2.0			T.P.I.: 8		CUTTER DIA: .375	
	"T"	"E"	"H"	"S"	"L"	"I"
MAXIMUM	.940	.856	.661	.061	.495	
MINIMUM	.924	.840	.631	.031	.465	.516
MEAN	.932	.848	.646	.046	.480	
FILL POINT CAPACITY: 12.00 FL.OZ. (354.95ml)						
OVERFLOW CAPACITY: 12.84 FL.OZ. ±.51 (379.70ml ±15.09)						
GRAM WEIGHT: 28.0 GRAMS ±2.0						
PRODUCT MATERIAL: H.D.P.E.						

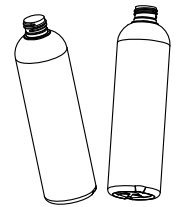
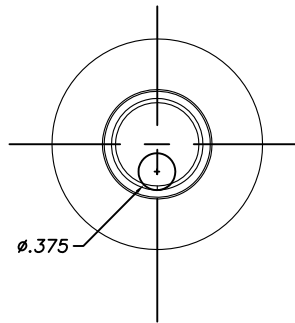

SCALE 4 : 1

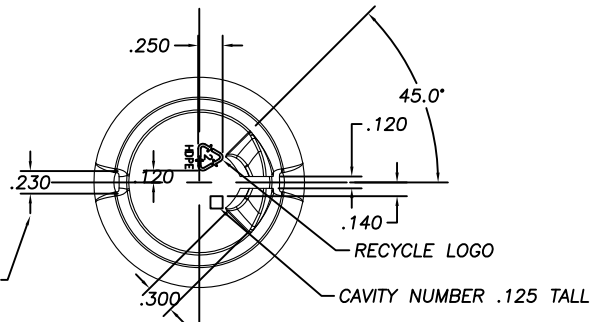
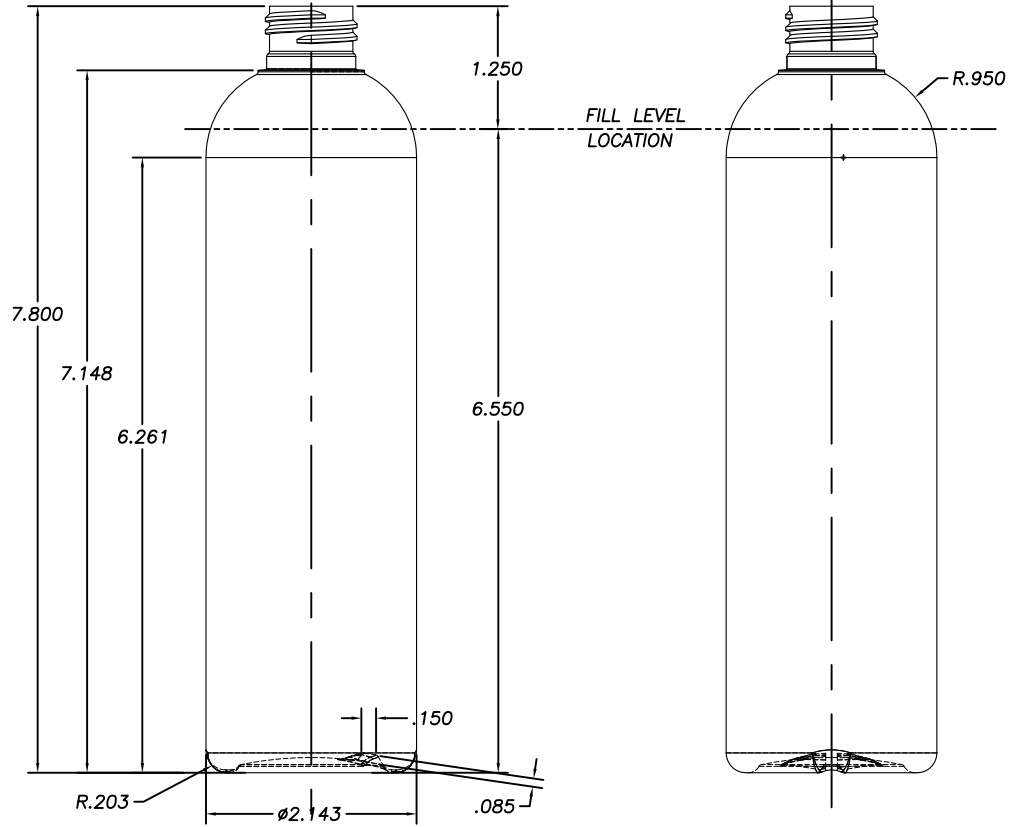

DO NOT SCALE DRAWING



PB1801

PRODUCT NAME: 12 oz BULLET ROUND

DRAWN BY:	DATE:	SCALE: 1 : 1
REVISION: 5	PAPER SIZE: C	JOB NO.