



Self-contained ice maker - Sprayer system Daily production up to 75 kg

Hotel	████████████████████
Restaurant	██████████████████
Fast food	██████████████
Bar	██████████████████
Disco	██████████████████
Fish market	██████████████
Supermarket	██████████████
Medical & SPA	██████████████
Industry	██████████████

► Position n°



► Features & Plus

- Compact and crystal cube
- AISI 304 SS Scotch Brite finish
- Tropical class +43°C
- Adjustable Stainless Steel feet
- Removable and cleanable air filter
- Air or water cooling system
- Easy cleanable internal rounded surfaces
- HCFC-Free insulated storage
- RoHS Free
- Disappearing insulated door
- Electromechanical operation
- ON-OFF rocker switch
- Standard and special voltages



AISI 304 SS Scotch Brite finish



Adjustable Stainless Steel feet



Removable and cleanable air filter



Disappearing insulated door

► Available ice cube size

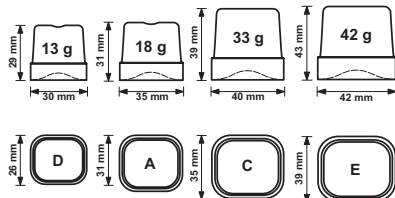

► Prod. 24h

Air temp.	Water temp.	kg	lbs		
		10° C	50° F	7° C	45° F
21° C	70° F	15° C	60° F	67	148

2 Years Warranty
subject to limitations

► Certifications available for this model





Ice Cube

CB 674



Self-contained ice maker - Sprayer system Daily production up to 75 kg

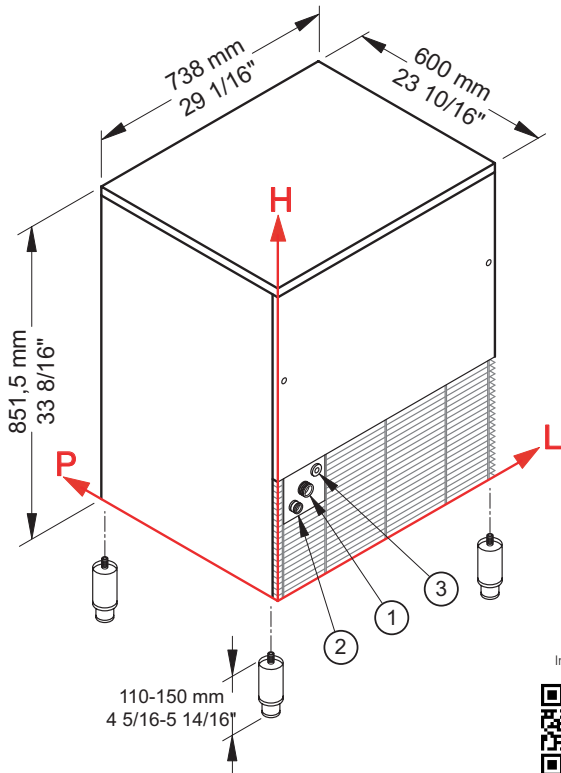

► Working conditions

- Location: **Indoor**

	Min	Max
Ambient temperature	+10° C / +50° F	+43° C / 110° F
Water temperature	+3° C / +37° F	+32° C / +90° F
Voltage	-10%	+10%
Water inlet pressure	1bar (14 psi)	6bar (84 psi)

► Performances

	Air temperature	Water temperature	Water temperature					
			7° C	45° F	15° C	60° F	21° C	70° F
	10° C	75 kg						
	50° F	165 lbs						
	21° C		67 kg					
	70° F			148 lbs				
	32° C				56 kg			
	90° F					123 lbs		

► Connections

All measures are referred to the rear bottom-left corner (L-H-Ø)

- ① Water in.: 116 mm / 4 9/16" - 220 mm / 8 11/16" - 3/4" ② Water out.: 54 mm / 2 2/16" - 180 mm / 7 1/16" - 24 mm / 15/16"
- ③ Electrical connections: 161 mm / 6 5/16" - 256 mm / 10 1/16"

► Technical information

Production in 24h	67 kg / 148 lbs
Store capacity, up to	40 kg / 88 lbs
Cooling system	A - W
Kind of cube	A-18g, C-33g, D-13g, E-42g
Refrigerant	R452A
Standard voltage	220-240 V ~ 50 Hz
Average power consumption	650 W
Fuse	10 A
Finish	AISI 304 stainless steel, scotch brite

Water consumption	A: 2,8 l/kg - 33,6 gal/100 lbs
	W: 12,8 l/kg - 153,4 gal/100 lbs
Sizes (L-P-H mm)	738 - 600 - 851,5
(L-P-H in)	29 1/16 - 23 10/16 - 33 8/16
Sizes with pack (L-P-H mm)	780 - 640 - 1015
(L-P-H in)	30 11/16 - 25 3/16 - 39 15/16
Net weight	72 kg / 159 lbs
Gross weight	84 kg / 185 lbs

All the technical information need to be considered at the following conditions:

- Standard Cube (18 g)
- Ambient temperature +21° C
- Water temperature +15° C
- Average power consumption at +43° C (standard voltage)

Models and specifications are subject to change without notice

Rev. 00 - Issued March 2021



www.bremaice.it
info@bremaice.it

We are Brema

