

### James Bar Cart

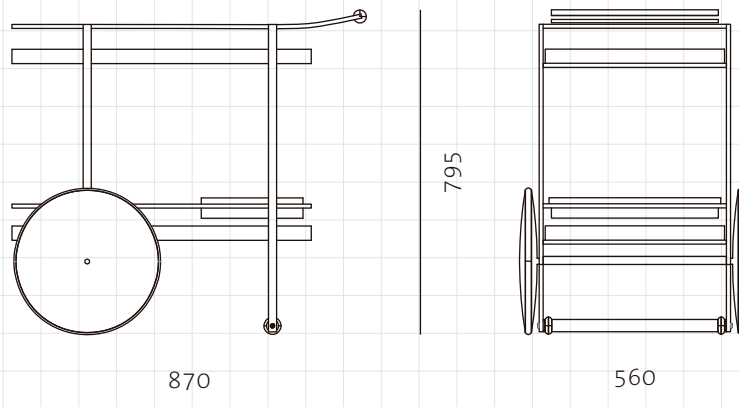

**CODE**

JA-CA110

**DIMENSIONS**

W870 x D560 x H795mm

**NET WEIGHT**

27.5 kg

**ENVIRONMENT**

Indoor

**MATERIALS**

Powder coated steel frame, veneer laminate panels, solid walnut

\*Please refer to website or contact your local representative for complete material swatches.

**SHIPPING**

<b>Package</b>	Assembled		
<b>Package Qty</b>	1 pcs/box		
<b>Packaging</b>	<b>Measurement (mm)</b>	<b>Volume (cbm)</b>	<b>Gross Weight (kg)</b>
<b>FCL</b>	W935 x D625 x H880	0.51	34.33
<b>LCL/AIR</b>	W955 x D645 x H975	0.60	41.49