

MÜN
BY OEO STUDIO

Mün Rechargeable Lantern

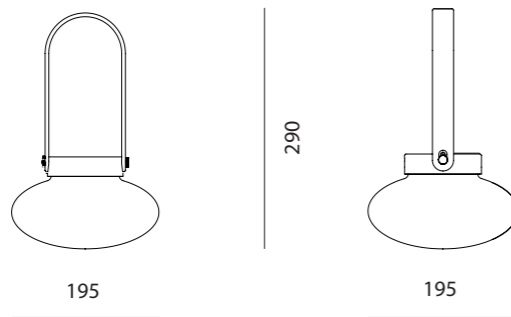

CODE	MN-R110																
DIMENSIONS	Ø195 x H290mm																
NET WEIGHT	0.70 kg																
ENVIRONMENT	Outdoor																
MATERIALS	Powder coated steel frame, silicone handle, glass shade *Please refer to website or contact your local representative for complete material swatches.																
LIGHT SOURCE	LED integrated, 2.1w / 130lm																
DIMMING	3 level touch dimmer 100% – 33% – 10 %																
COLOR TEMPERATURE	2700k																
CERTIFICATIONS	ETL (DC 25V) CE (DC 5V)																
SHIPPING	<table><tr><td>Package</td><td>Assembled</td><td></td><td></td></tr><tr><td>Package Qty</td><td>6 pcs/box</td><td></td><td></td></tr><tr><td>Packaging</td><td>Measurement (mm)</td><td>Volume (cbm)</td><td>Gross Weight (kg)</td></tr><tr><td>FCL/LCL/AIR</td><td>W585 x D415 x H585</td><td>0.14</td><td>8.60</td></tr></table>	Package	Assembled			Package Qty	6 pcs/box			Packaging	Measurement (mm)	Volume (cbm)	Gross Weight (kg)	FCL/LCL/AIR	W585 x D415 x H585	0.14	8.60
Package	Assembled																
Package Qty	6 pcs/box																
Packaging	Measurement (mm)	Volume (cbm)	Gross Weight (kg)														
FCL/LCL/AIR	W585 x D415 x H585	0.14	8.60														

