

MÜN
BY OEO STUDIO

Mün Pendant Large

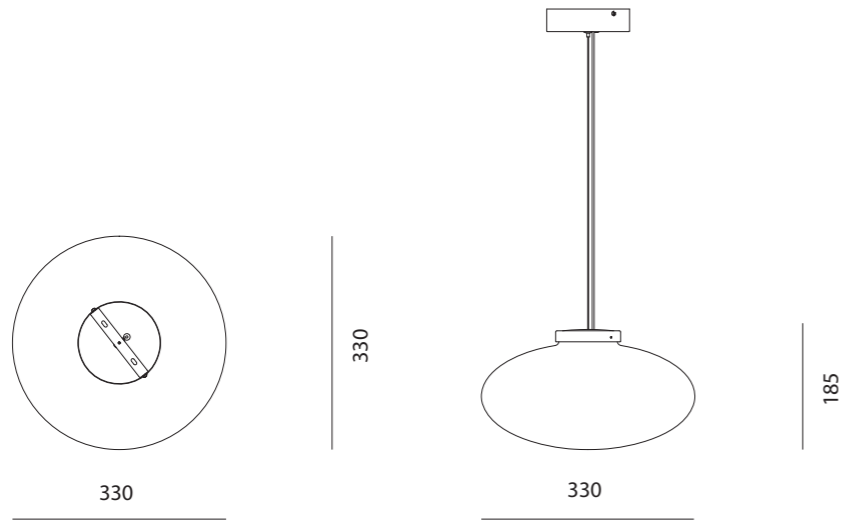

| | |
|--------------------------|--|
| CODE | MN-P110-L |
| DIMENSIONS | Ø330 x H185mm |
| NET WEIGHT | 2.35 kg |
| ENVIRONMENT | Indoor |
| MATERIALS | Powder coated steel frame, glass shade <small>*Please refer to website or contact your local representative for complete material swatches.</small> |
| LIGHT SOURCE | LED integrated, 20w / 1600lm |
| DIMMING | 1-10V dimming, and the dimmer need to be prepared by the user |
| COLOR TEMPERATURE | 2700k |
| CABLE LENGTH | 3m |
| CERTIFICATIONS | ETL (110-120V~60Hz) CE (DC 110-240V~50Hz) CCC (DC 220-240V~50Hz) |
| SHIPPING | |
| Package | Assembled |
| Package Qty | 1 pcs/box |
| Packaging | Measurement (mm) Volume (cbm) Gross Weight (kg) |
| FCL/LCL/AIR | W400 x D400 x H340 0.05 3.72 |

