

HARO  
BY SPACE COPENHAGEN

Haro Pendant

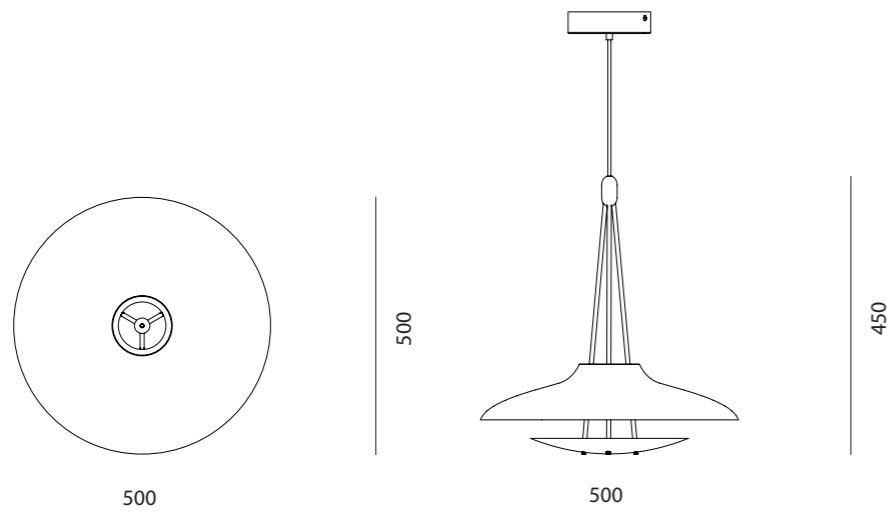

CODE  
DIMENSIONS

HA-P110  
Ø500 x H450mm

NET WEIGHT  
ENVIRONMENT  
MATERIALS

3.0 kg  
Indoor  
Powder coated steel shade, brass plated stainless steel structure  
\*Please refer to website or contact your local representative for complete material swatches.

LIGHT SOURCE  
DIMMING  
COLOR TEMPERATURE  
CABLE LENGTH  
CERTIFICATIONS

LED integrated, 12w non-dimmable LED / 1075lm  
12W non-dimmable LED  
2700k  
3m  
ETL (24VDC, 0.67A) | CE (24VDC, 0.67A) | CCC (24VDC, 0.67A)

SHIPPING

<b>Package</b>	Assembled		
<b>Package Qty</b>	1 pcs/box		
<b>Packaging</b>	<b>Measurement (mm)</b>	<b>Volume (cbm)</b>	<b>Gross Weight (kg)</b>
<b>FCL/LCL/AIR</b>	W580 x D580 x H575	0.19	3.14

