

## PG200HF

SKOPE Pegasus Horizontal 2/1  
INTEGRAL 1 Door Freezer (JK1301)

### CABINET DIMENSIONS

|                    | External           | Internal |
|--------------------|--------------------|----------|
| <b>Height:</b>     | 771mm*             | 565mm    |
| <b>Width:</b>      | 1065mm             | 565mm    |
| <b>Depth:</b>      | 828mm              | 650mm    |
| <b>Floor area:</b> | 0.88m <sup>2</sup> |          |

\* Height includes plinth and worktop (excludes castors and adjustable legs).

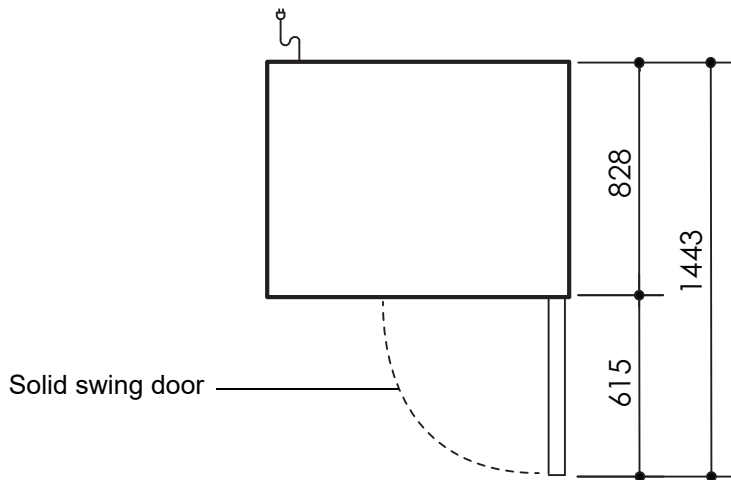

**Dimensional tolerances**  
Before installing this cabinet allow the following dimensional tolerances:

| Linear dimensions | Overall cabinet dimensions | Length of multiple cabinets |                  |
|-------------------|----------------------------|-----------------------------|------------------|
|                   |                            | At each joint               | At each end wall |
| Less than 1 metre | ±5mm                       | ±5mm                        | +15mm            |
| More than 1 metre | -5mm to +10mm              | -5mm to +10mm               | +15mm            |

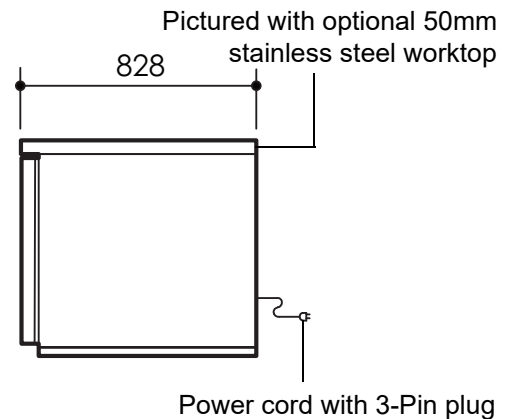
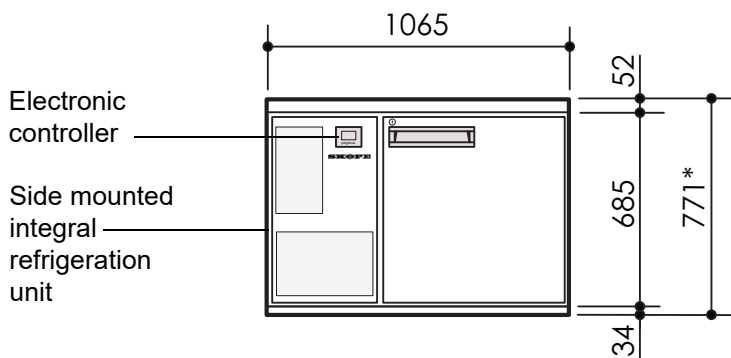

Copyright © 2012 SKOPE Industries Limited

### CABINET SPECIFICATIONS

|                                    |   |
|------------------------------------|---|
| <b>Refrigeration system:</b>       | Electronic controlled, side mounted, integral refrigeration unit      |
| <b>Refrigerant:</b>                | R452A / 750g  |
| <b>Nominal capacity:</b>           | 180 Watts @ -30°C SST   |
| <b>Cabinet internal volume:</b>    | 210 litres  |
| <b>Insulation:</b>                 | 60mm thick, high density cyclo-isopentane polyurethane foam           |
| <b>Cabinet temperature range:</b>  | -18°C to -21°C up to 43°C ambient                                     |
| <b>Drainage:</b>                   | No plumbing required  |
| <b>Electrical:</b>                 | 230-240 Volts a.c. 50 Hz, 3.00 Amps                                   |
| <b>Internal lighting:</b>          | n.a.  |
| <b>Internal door opening size:</b> | 1 door opening: 565mm high x 565mm wide                               |
| <b>Door:</b>                       | Solid stainless steel, self-closing door (with key lock) - RH hinged  |
| <b>Worktop (optional):</b>         | Optional 50mm square edged stainless steel worktop                    |
| <b>Shelves:</b>                    | Two levels of non-tip, adjustable tray slides and/or shelves per door |
| <b>Weight:</b>                     | 132 kg  |

SKOPE Industries Limited reserve the right to alter specifications without notice.

PSS0295 Rev 2.2 Nov. 2019



**SKOPE INDUSTRIES LIMITED**



New Zealand Freephone: 0800 947 5673, Fax: (03) 983 3896. Australian Freephone: 1800 121 535, Freefax: 1800 121 533

Email: enquiry@skope.co.nz Website: www.skope.co.nz