

PINNACLE SERIES

STAINLESS STEEL 3 BURNER PATIO GAS BRAAI

ASSEMBLY & OPERATING INSTRUCTIONS



This instructions manual contains important information necessary for the proper assembly and safe use of the appliance.

Read these instructions and warnings carefully so as to familiarize yourself with the appliance before connecting it to its gas container.

Keep this manual for future reference.

megamaster[™]
TOGETHER, MADE BETTER[™]

MODEL NO. 720-0925SD



Questions, problems, missing parts?
Before returning to your retailer, call our Customer Service Department at Tel: +27 (12) 802 1515, CAT, Monday – Thursday 07:30 – 17:00 Friday 07:30 – 14:00
Or send us an E-mail at service@megagroup.co.za. Visit us online at: www.megamaster.co.za

19001107A0

THIS MANUAL IS DESIGNED TO FIT INTO THE BOTTOM DRAWER.

BUT THAT'S NOT WHERE IT BELONGS

We get it. You've just unboxed your Megamaster Pinnacle 3 Burner Patio Gas Braai and you can't wait to fire it up. Those steaks, fish, vegetables and everything else you could possibly imagine certainly aren't going to braai themselves.

At Megamaster, we believe anything worth doing is worth doing well. That's why, as with all of our products, we've put a lot of thought and effort into this user manual. It really is the first step towards making your time with friends, family and flavour truly better.

Manufactured in China. Distributed by Megamaster
+27 (0)12 802 1515 PO Box 15, Woodlands, 072, South Africa

www.megamaster.co.za

megamaster[™]
TOGETHER, MADE BETTER[™]

TABLE OF CONENTS



Safety Warnings	3	Leak Test Instructions	25
Braai Clearance Information	4	Ignition Instructions	27
Operation Warnings	6	Care and Maintenance.	29
LP Gas Supply Safety	7	Troubleshooting Guide	30
Package Parts List	9	Burner Replacement	31
Assembly Instructions	11	Parts Diagram	32
Gas Hookup Instructions.	24	Warranty	34

SAFETY WARNINGS



⚠ DANGER

If you smell gas:

1. Shut off gas to the appliance.
2. Extinguish any open flame.
3. Open lid.
4. If odour continues, keep away from the appliance and immediately call your gas supplier or your fire department.

⚠ WARNING

1. Do not store or use petrol or other flammable liquids or vapour in the vicinity of this or any other appliance.
2. Do not store spare LP gas cylinders or butane cartridges in the vicinity of the braai or other appliances.

⚠ WARNING

1. To reduce the risk of fire, burn hazard or other injury, read the manual carefully and completely before using your braai.
2. Your braai will get very hot. Never lean over the cooking area while using your braai. Do not touch cooking surfaces, braai housing, lid or any other braai parts while the braai is hot and in operation, or until the gas braai has cooled down after use.
3. Failure to comply with these instructions may result in serious bodily injury / death.
4. DO NOT LEAVE THE BRAAI UNATTENDED WHILE COOKING.
5. FOR OUTDOOR USE ONLY.

⚠ DANGER

1. Never use your gas braai in a garage, porch, shed, or any other enclosed area.
2. **DO NOT** use this appliance under overhead combustible surfaces.
3. Do not install this unit in combustible enclosures.
4. The minimum air space clearance from sides and back of unit to combustible construction is 36 in. (91cm) from the sides and 36 in. (91cm) from the back.
5. Never operate this appliance within 10 ft. (3 m) of any structure, combustible material or other LP gas cylinder.
6. Never operate this appliance within 25 ft. (7.5 m) of any flammable substance.
7. This braai is not intended to be installed in or on recreational vehicles and/or boats..
8. **DO NOT USE ALUMINUM FOIL TO LINE THE BRAAI RACKS OR BRAAI BOTTOM.**
This can severely upset combustion air flow or trap excessive heat in the control area.

ELECTRICAL WARNINGS

⚠ WARNING

1. To ensure continued protection against risk of electric shock, connect to properly grounded outlets only. To reduce the risk of electric shock, keep extension cord connection dry and off the ground.
2. If an external electrical source is utilized for lights or rotisserie motors: The outdoor cooking gas appliance, when installed, must be electrically grounded in accordance with local building regulations.
3. Keep any electrical supply cord and the fuel supply hose away from any heated surfaces.

⚠ WARNING

1. Do not try lighting this appliance without reading the “LIGHTING INSTRUCTIONS” section of this manual.

BRAAI INSTALLATION

1. Check your local building codes for the proper method of installation. In the absence of local codes, this unit should be installed in accordance with the South African National Standard 1539, Storage and Handling of Liquefied Petroleum Gases, Correct LP Gas Cylinder Use.
2. LP gas braai models are designed for use with a standard 9kg LP Gas cylinder, not included with braai. Never connect your gas braai to an LP gas cylinder that exceeds this capacity. Keep a spray bottle of soapy water near the gas supply valve and check the connections before each use.

NOTE: The normal flow of gas through the regulator and hose assembly can create a humming noise. A low volume of noise is perfectly normal and will not interfere with operation of the braai. If humming noise is loud and excessive you may need to purge air from the gas line or reset the regulator excess gas flow device. This purging procedure should be done every time a new LP gas cylinder is connected to your braai.

SPIDER WARNINGS

CAUTION: Beware of Burn-Back

CAUTION: Spiders and small insects occasionally spin webs or make nests in the braai burner tubes during transit and warehousing. These webs can lead to gas flow obstruction, which could result in a fire in and around burner tubes. This type of fire is known as “BURN-BACK” and can cause serious damage to your braai and create an unsafe operating condition for the user.

Although an obstructed burner tube is not the only cause of “BURN-BACK”, it is the most common cause.

In the event of “BURN-BACK”, where the flame burns back to the jet, immediately turn off the gas supply at the burner control valve.

After ensuring that the flame is extinguished, re-light the appliance as described below. Should the appliance again “BURN-BACK”, close the valves and examine the mixing tube or burner for any obstructions. If there are no obstructions and the burn back still occurs, call a technician to examine the appliance and make any necessary repairs.

Do not make any adjustments or modifications to this braai, a qualified LP gas technician should do any adjustments.

To reduce the chance of “BURN-BACK”, you must clean the burner tubes before assembling your braai, and at least once a month for maintenance. Also perform this burner tube cleaning procedure if your braai has not been used for an extended period of time. A clogged tube can lead to a fire beneath the braai.

SAFETY PRACTICES TO AVOID PERSONAL INJURY

When properly cared for your braai will provide safe, reliable service for many years. However, extreme care must be used as the braai produces intense heat that can increase risk of injury. When using this appliance basic safety practices must be followed, including the following:

- Do not repair or replace any part of the braai unless specifically recommended in this manual. All other services should be referred to a qualified technician.
- Children and pets should not be left alone or unattended in an area where the braai is being used. Do not allow them to sit, stand or play in or around the braai at any time.
- Do not store items of interest to children around the braai.
- Do not permit clothing, pot holders or other flammable materials to come in contact with or too close to any grate, burner or hot surface of the braai until it has cooled down completely. The fabric could ignite and cause personal injury.
- Loose fitting garments or sleeves should never be worn while using this appliance. Some synthetic fabrics are highly flammable and should not be worn while cooking.
- Only certain types of glass, heat-proof glass ceramic, earthenware, or other glazed utensils are suitable for use on the braai. These materials may break with sudden temperature changes. Use only on low or medium heat settings in accordance with the manufacturer's guidelines.
- Do not heat unopened food containers on the braai. A build-up of pressure may cause the containers to burst.
- Ensure that your hand is covered with protective gear when opening the braai lid. Never lean over an open braai.
- When lighting a burner, pay close attention to what you are doing. Make certain you are aware of which burner you are lighting, so your body and clothing remain clear of open flames.
- When using the braai, do not touch the braai rack, burner grate or immediate surroundings as these areas become extremely hot and could cause injury. Use only dry potholders. Moist or damp potholders on hot surfaces may cause steam burns. Do not use a towel or bulky cloth in place of potholders. Do not allow potholders to touch hot portions of the braai rack.
- Grease is flammable. Let hot grease cool before attempting to handle it. Do not allow grease deposits to collect in the grease tray at the bottom of the braai's firebox. Clean the grease tray after each use.
- Do not use aluminum foil to line the braai racks or braai bottom. This can severely upset combustion air flow or trap excessive heat in the control area. For proper lighting and performance of the burners keep the burner ports clean. It is necessary to clean them periodically for optimum performance. The burners will only operate in one position and must be mounted correctly for safe operation.
- Clean the braai with caution. To avoid steam burns, do not use a wet sponge or cloth to clean the braai while it is hot. Some cleaners produce toxic fumes or can ignite if applied to a hot surface.
- Turn off braai controls and make certain the braai is cool before using any type of aerosol cleaner on or around it. The chemical that produces the spraying action could, in the presence of heat, ignite or cause metal parts to corrode.
- Do not use the braai to cook excessively fatty meats or other products which promote flare – ups.
- Keep the area surrounding the braai free from combustible materials including, fluids, trash and vapours such as gasoline or charcoal lighter fluid. Do not obstruct the flow of combustion and ventilation air.

- If this information is not followed exactly, a fire resulting in death or serious injury could occur.
- A Gas cylinder of maximum 9kg are to be used with this braai.
- The gas cylinder to be used must be constructed and marked in accordance with the specifications for gas cylinders in RSA.
- The cylinder supply system must be arranged for vapour withdrawal.
- **Never** connect an unregulated gas cylinder to your gas braai.
- This outdoor cooking gas appliance is equipped with a high capacity hose/regulator assembly for connection to a gas cylinder of 9kg and with a valve.
- Do not store a spare LP gas cylinder in the vicinity of this appliance.
- Do not store or use gasoline or other flammable vapours and liquids in the vicinity of this or any other appliance.
- Storage of an outdoor cooking gas appliance indoors is permissible only if the cylinder is disconnected and removed from the outdoor cooking gas appliance.
- When your gas braai is not in use the gas must be turned off at LP gas cylinder.
- The gas must be turned off at the supply cylinder when the outdoor cooking gas appliance is not in use.
- Do not obstruct the flow of ventilation air around the gas braai housing. Only use the regulator and the hose assembly supplied with your gas braai. Replacement regulators and hose assemblies must be those specified in this manual.
- While igniting the braai, keep your face and hands as far away from the braai as possible.
- The regulator and hose assembly must be inspected before each use of the braai. If there is excessive abrasion or wear or if the hose is cut or damaged, it must be replaced prior to the braai being operated. The replacement hose assembly shall be that specified by the manufacturer.
- Pressure regulator and hose assembly supplied with the outdoor cooking gas appliance must be used. Never substitute other types of regulators. Contact customer service for manufacturer specified replacement parts.
- This outdoor cooking gas appliance is equipped with a pressure regulator that complies with the standard for LP gas products in South Africa National Standards 1237.
- The braai is designed for optimum performance without the use of briquettes, charcoal or wood. Do not place briquettes, charcoal or wood on the radiant as this will block off the area for the braai burners to vent. Adding briquettes can damage ignition components and knobs, and void the warranty.
- Keep the back and sides of the cart free and clear from debris. Keep any electrical supply cords, or the rotisserie motor cord away from the heated areas of the braai.
- Never use the braai in extremely windy conditions. If located in a consistently windy area (oceanfront, mountaintop, etc.) a wind shield will be required. Always adhere to the specified clearance area of 61 cm.
- Never use a dented or rusty gas cylinder.
- Keep any electrical supply cords and the fuel supply hose away from any heated surfaces.

**NOW THAT WE
GOT ALL THE
SAFETY
INFORMATION
OUT OF THE WAY,
LET'S START
WITH SOME
ELBOW GREASE!**

PACKAGE PARTS LIST



1



2

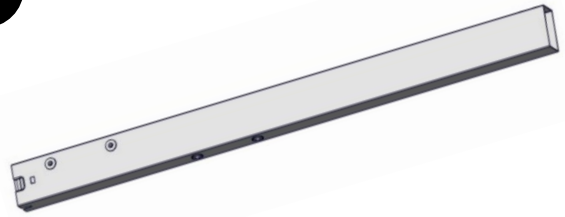

3

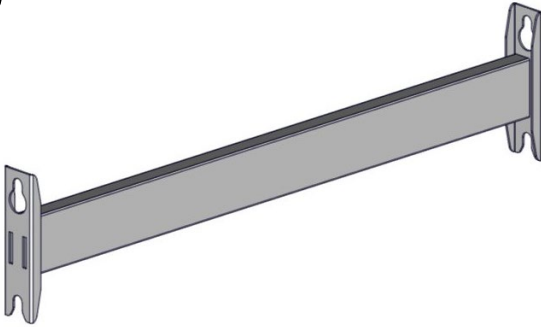

4

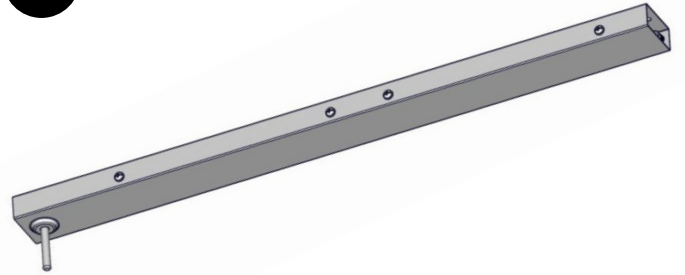

5

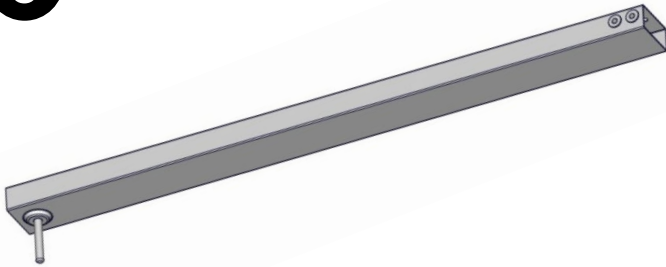

6

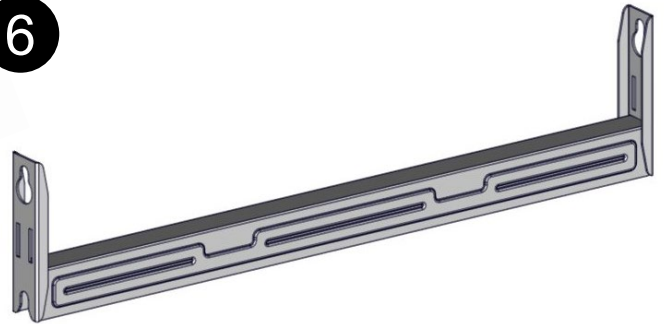

7

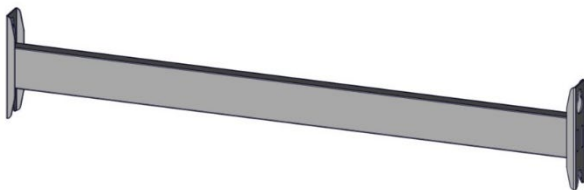

8

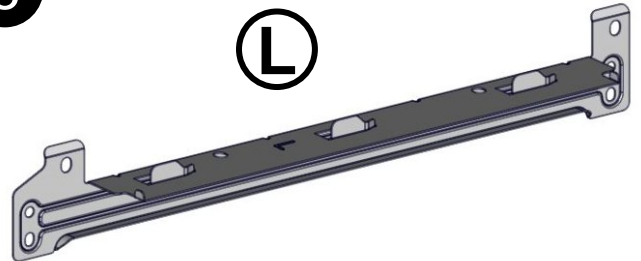

9

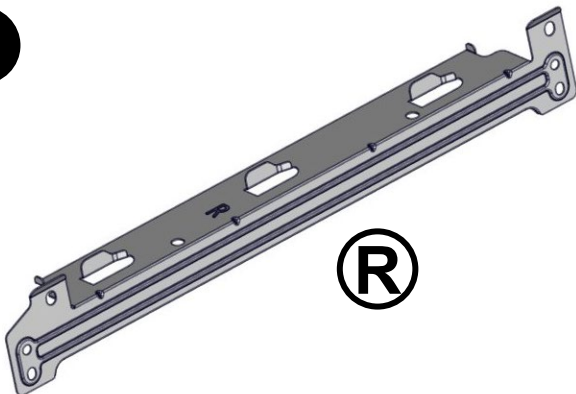

10

x2



PACKAGE PARTS LIST



11

x2

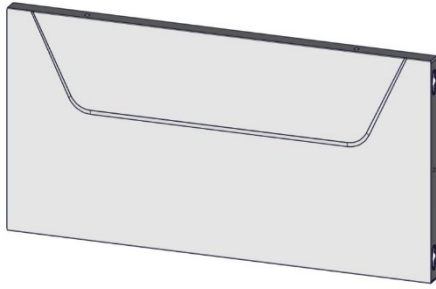

12

x2



13

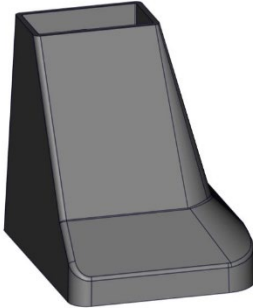

14

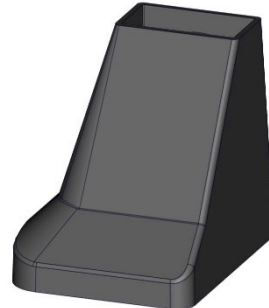

15

x2

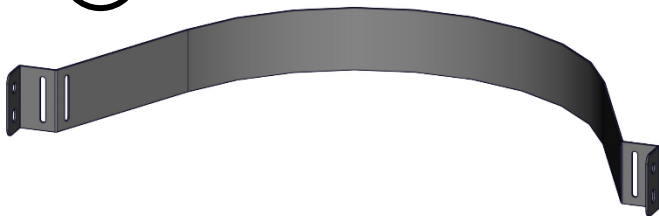

16

x2

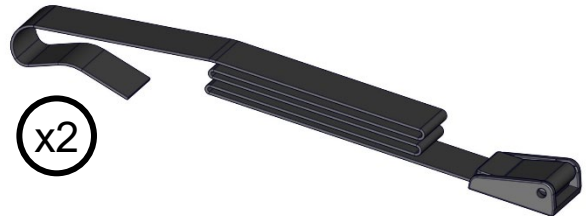

17

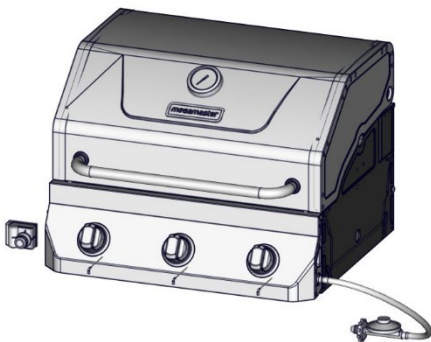

18

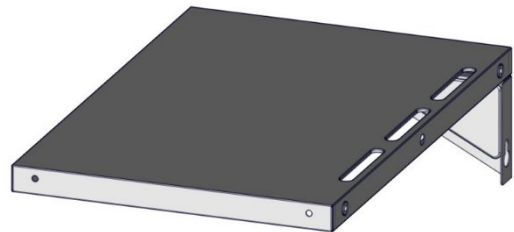

19

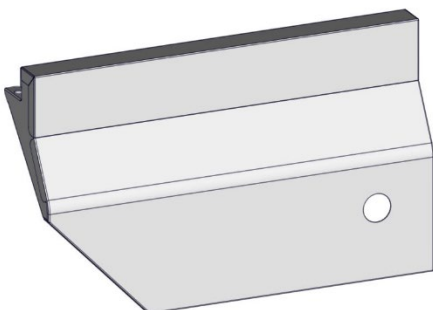

20

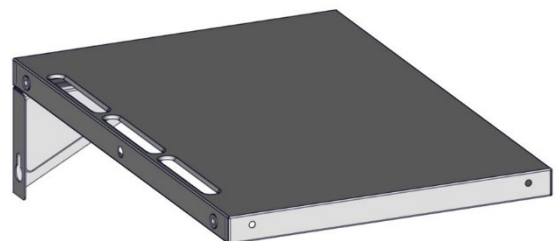

PACKAGE PARTS LIST



21

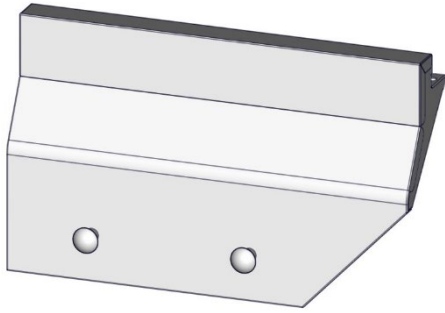

22

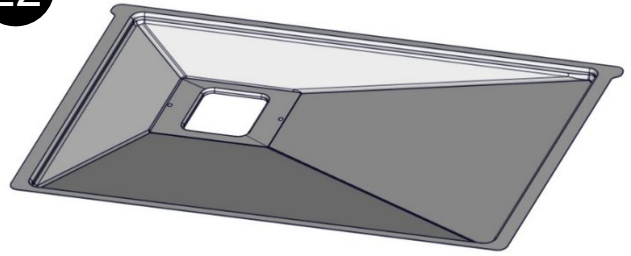

23

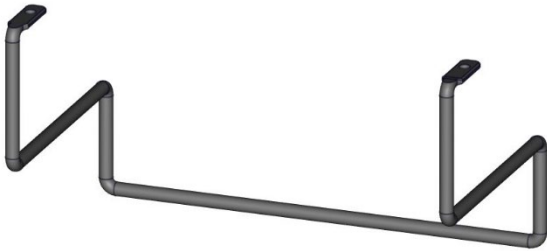

24

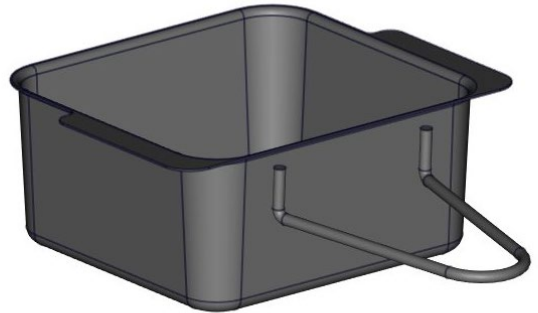

25

x3

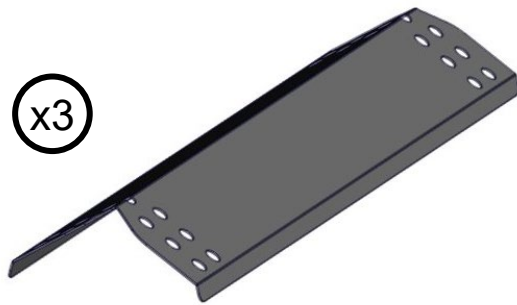

26

x2

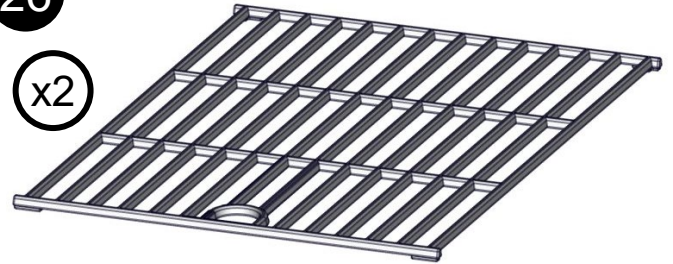

27

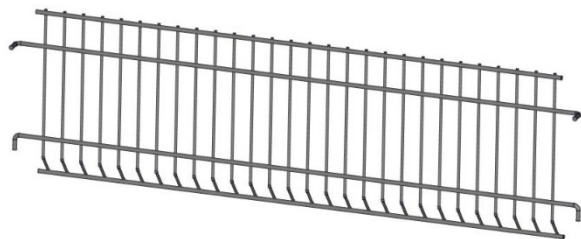

28

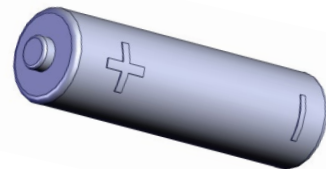

29

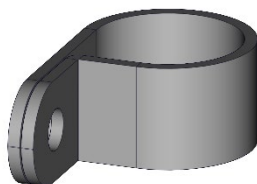

TOOLS NEEDED

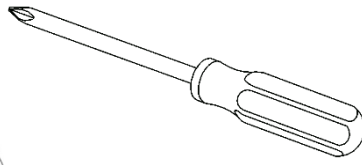
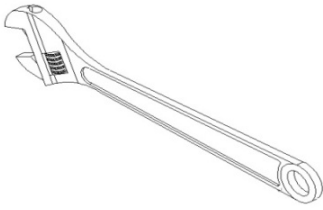

Some parts come with
Screws pre-installed.
Loosen and tighten for final
assembly.

HARDWARE PACKAGE LIST



Truss head screw
(Black)
1/4-20X1/2"

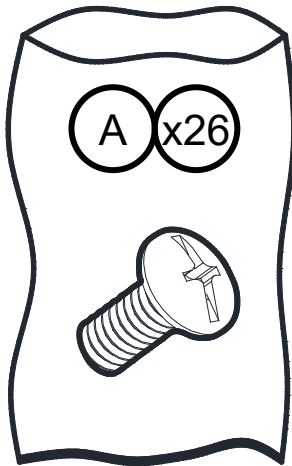

Truss head screw
(Black)
5/32-32 x 2/5"

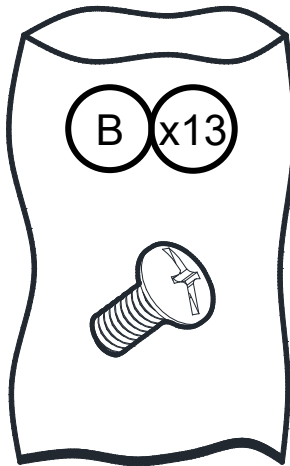

Flat Washer
1/4"

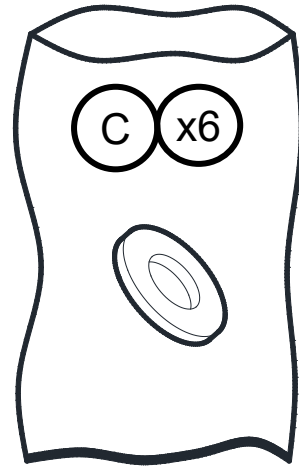

Flat Washer
5/32"

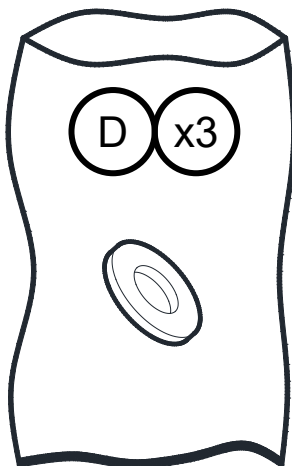

Wheel Nut
5/16"

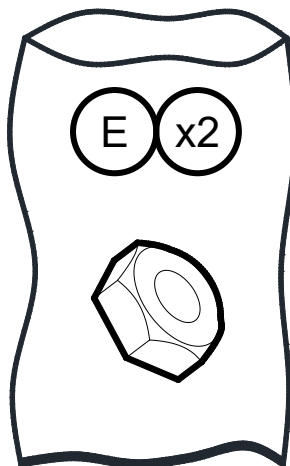

EXPLODED VIEW

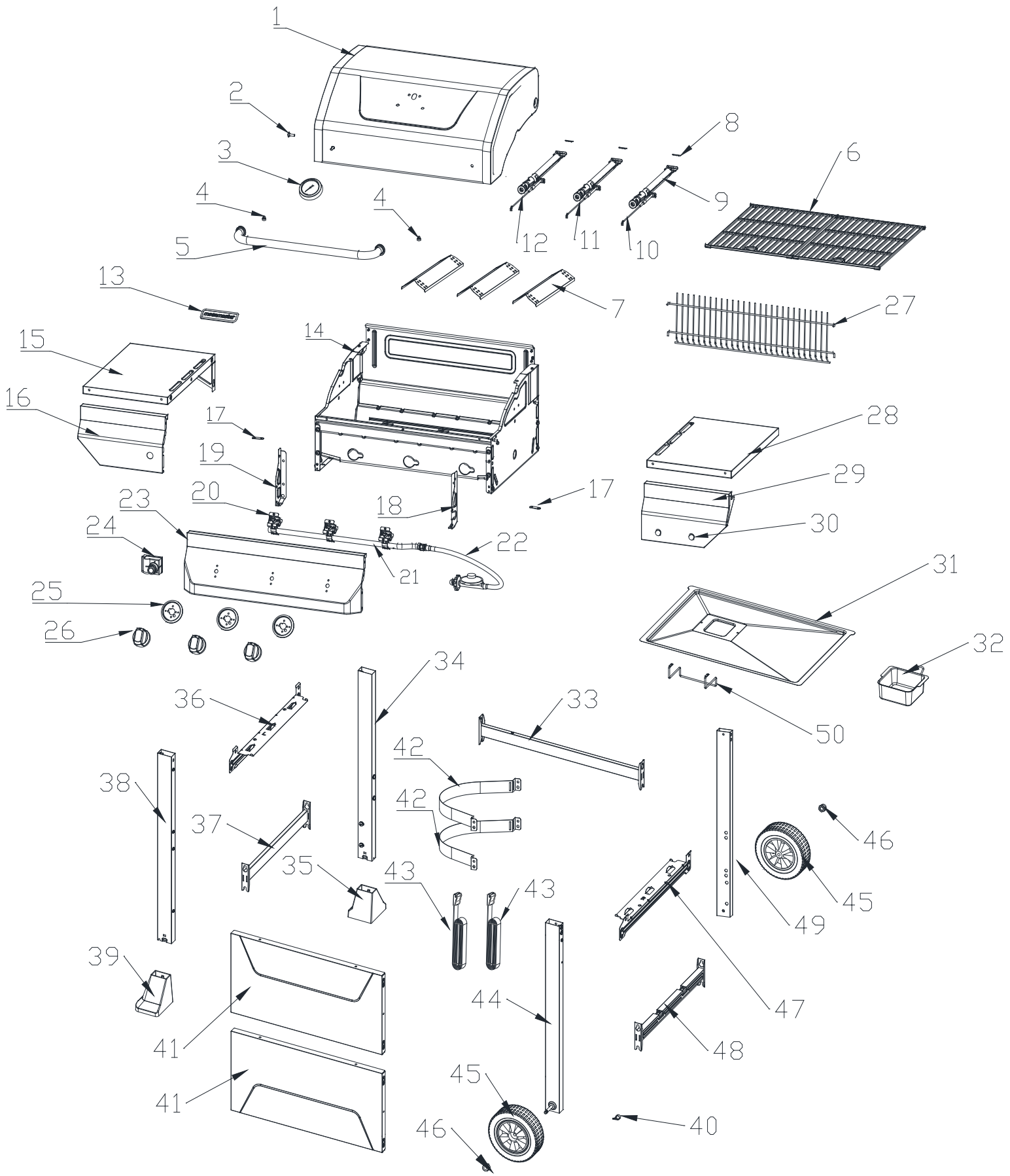

PART LIST



No.	Part (Description)	QTY	No.	Part (Description)	QTY
1	Main lid	1	28	Side shelf, right	1
2	Main lid screw assembly	2	29	Side shelf control panel, right	1
3	Temperature gauge	1	30	Tool hook	2
4	Hood buffer	2	31	Grease tray assembly	1
5	Main lid handle	1	32	Grease cup	1
6	Cooking grid	2	33	Rear cart frame	1
7	Flame tamer	3	34	Cart leg rear, left	1
8	R pin	3	35	Cart foot rear, left	1
9	Main burner	3	36	Cart frame top, left	1
10	Main burner igniter A	1	37	Cart frame bottom, left	1
11	Main burner igniter B	1	38	Cart leg front, left	1
12	Main burner igniter C	1	39	Cart foot front, left	1
13	Logo	1	40	Valve pipe nylon buckle	1
14	Firebox assembly	1	41	Cart front panel	2
15	Side shelf, Left	1	42	Gas tank bracket	2
16	Side shelf control panel, Left	1	43	Gas tank bind	2
17	Connect plate	2	44	Cart leg front, right	1
18	Right panel of main control panel	1	45	Wheel	2
19	Left panel of main control panel	1	46	Wheel screw assembly	2
20	Main gas valve	3	47	Cart frame top, right	1
21	Main manifold	1	48	Cart frame bottom, right	1
22	LP regulator with hose	1	49	Cart leg rear, right	1
23	Main control panel	1	50	Grease cup bracket	1
24	Pulse igniter module	1	51		
25	Bezel	3	52		
26	Control knob	3	53		
27	Warming rack	1	54		

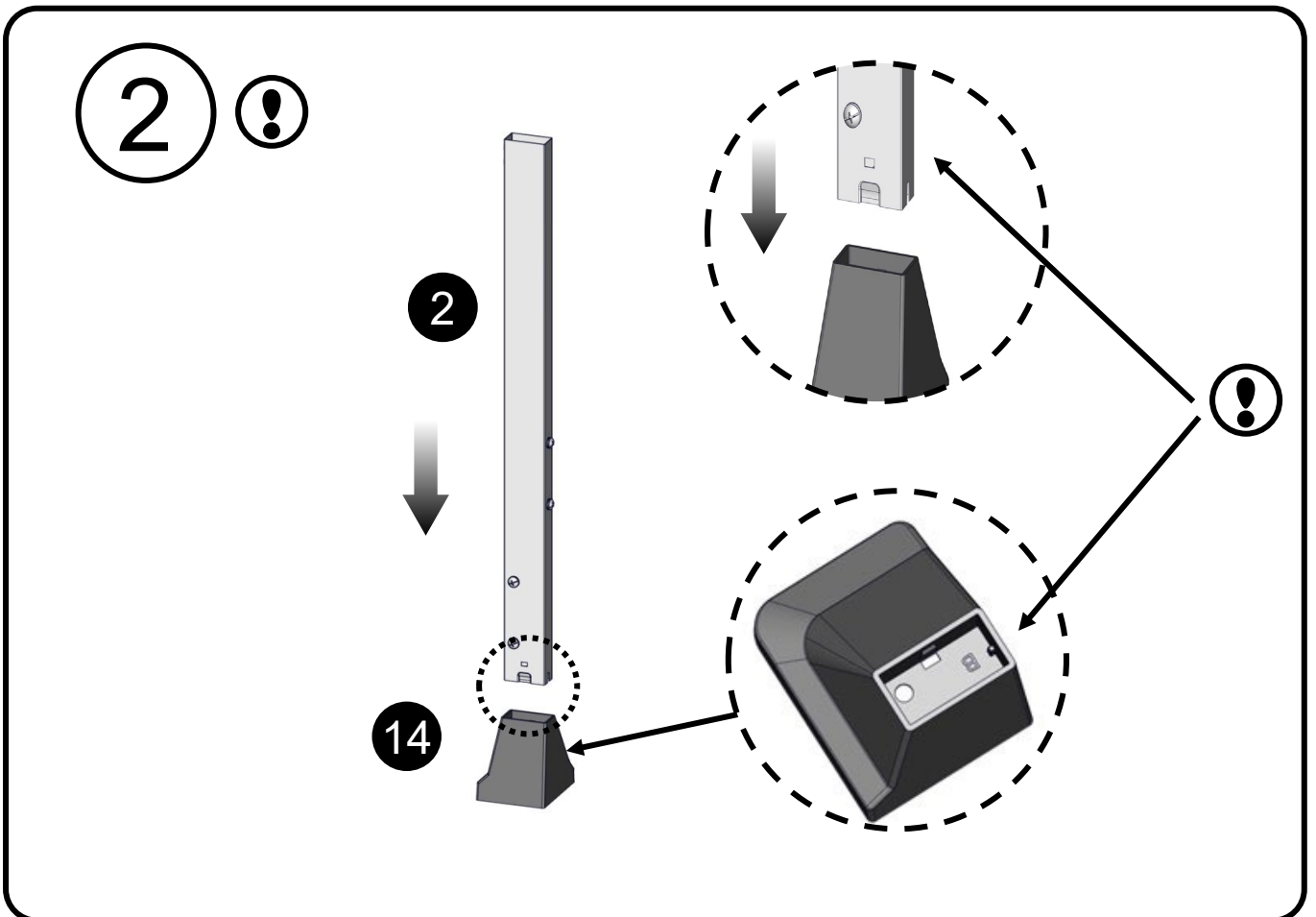
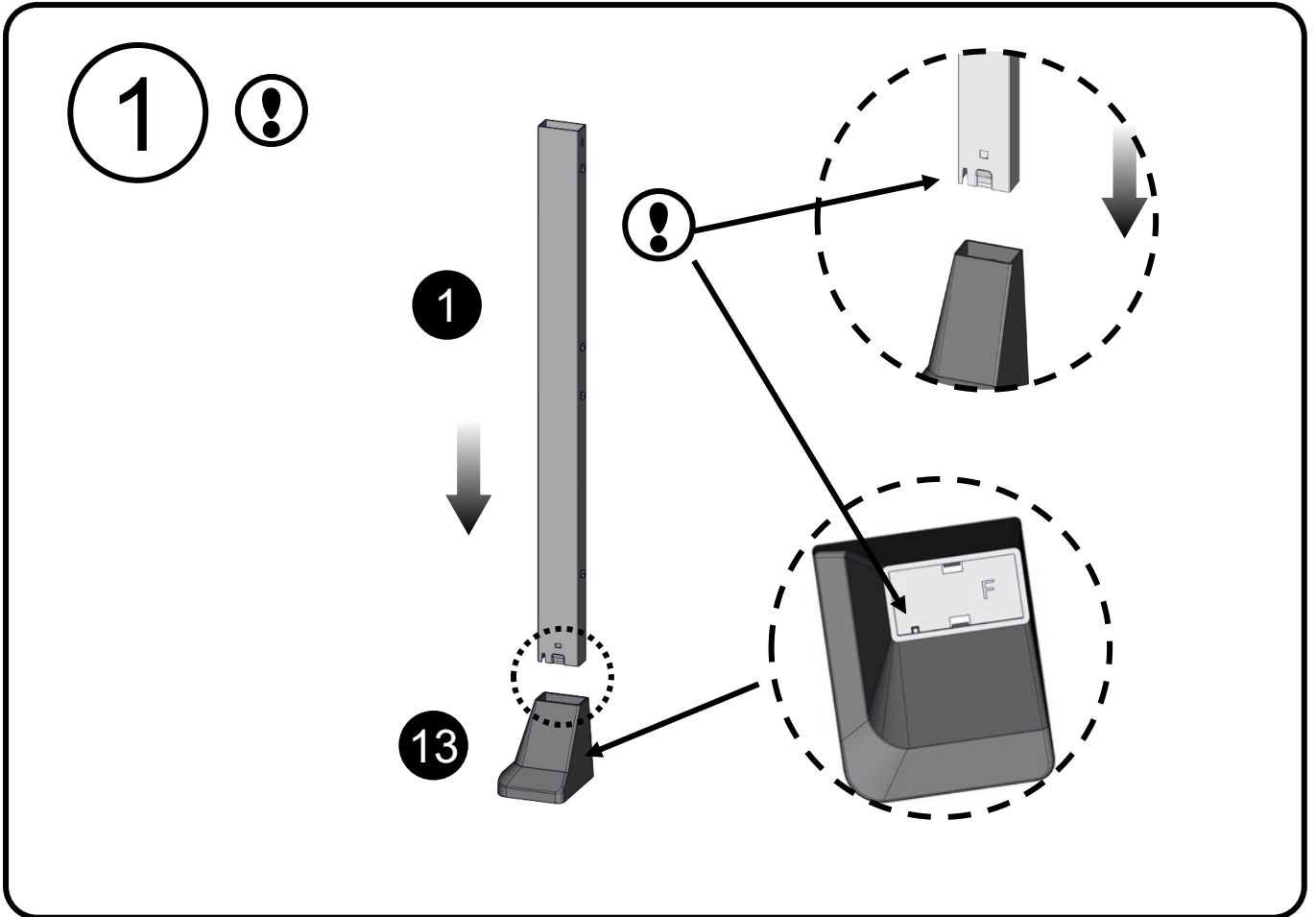

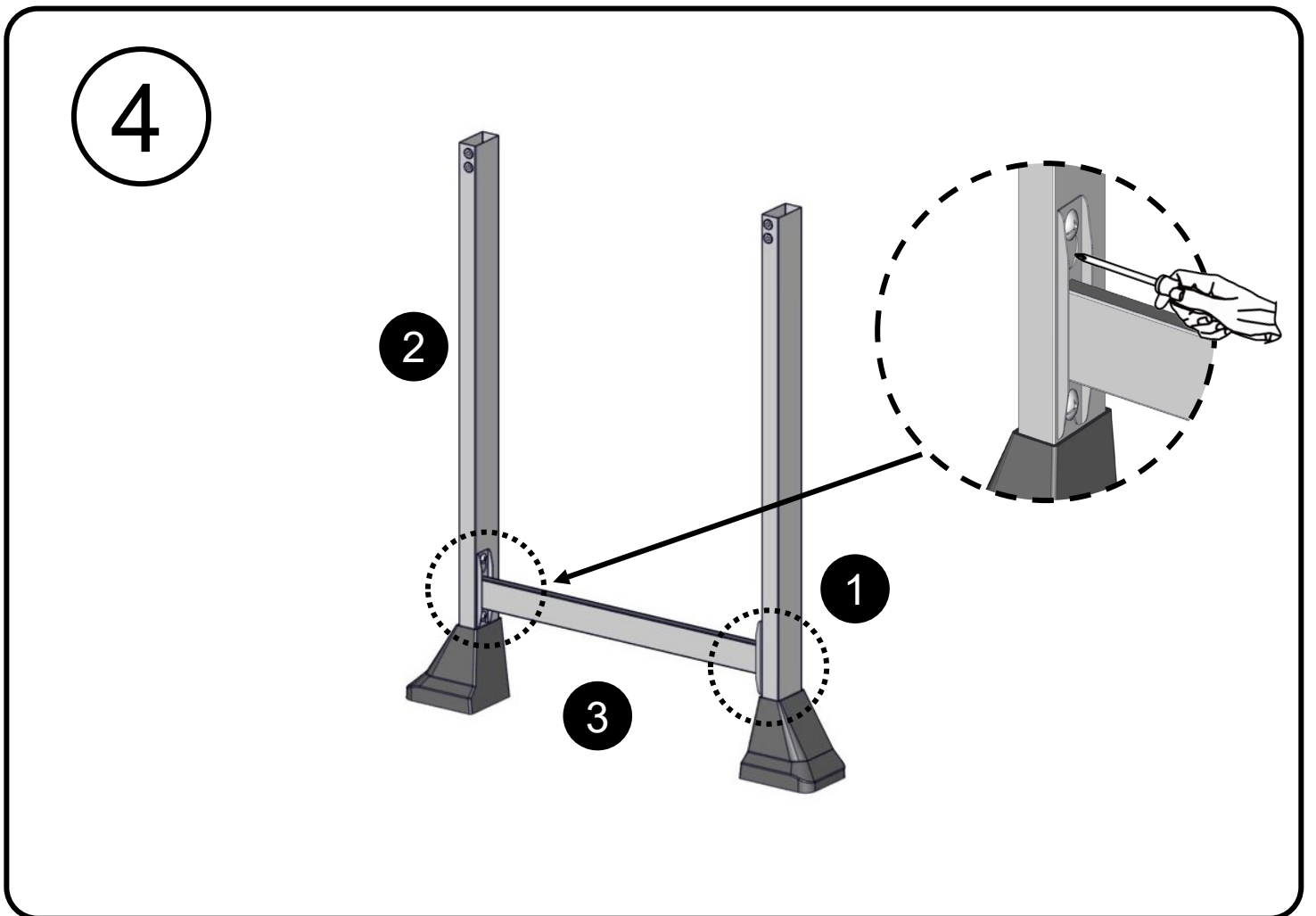
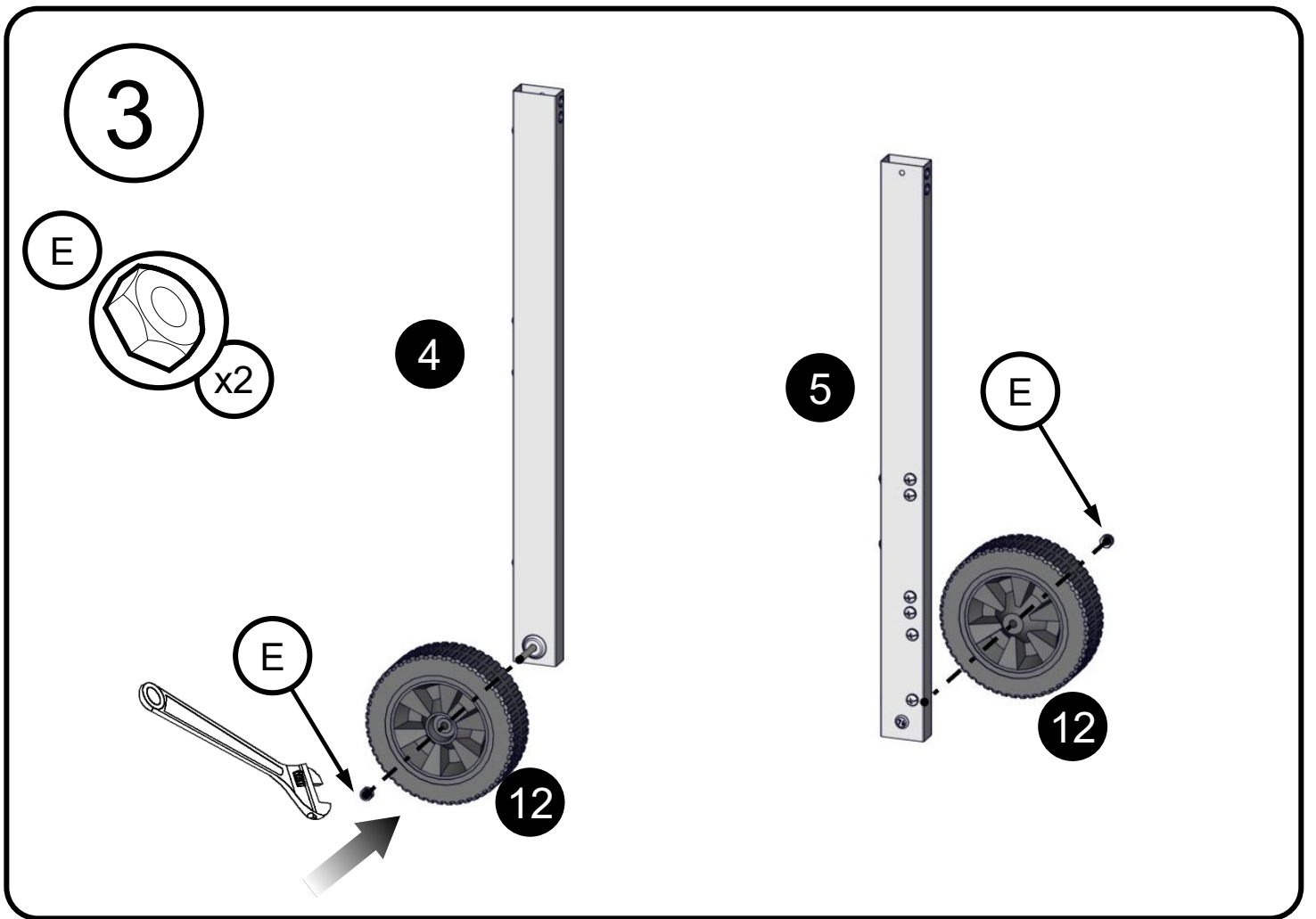

5 !

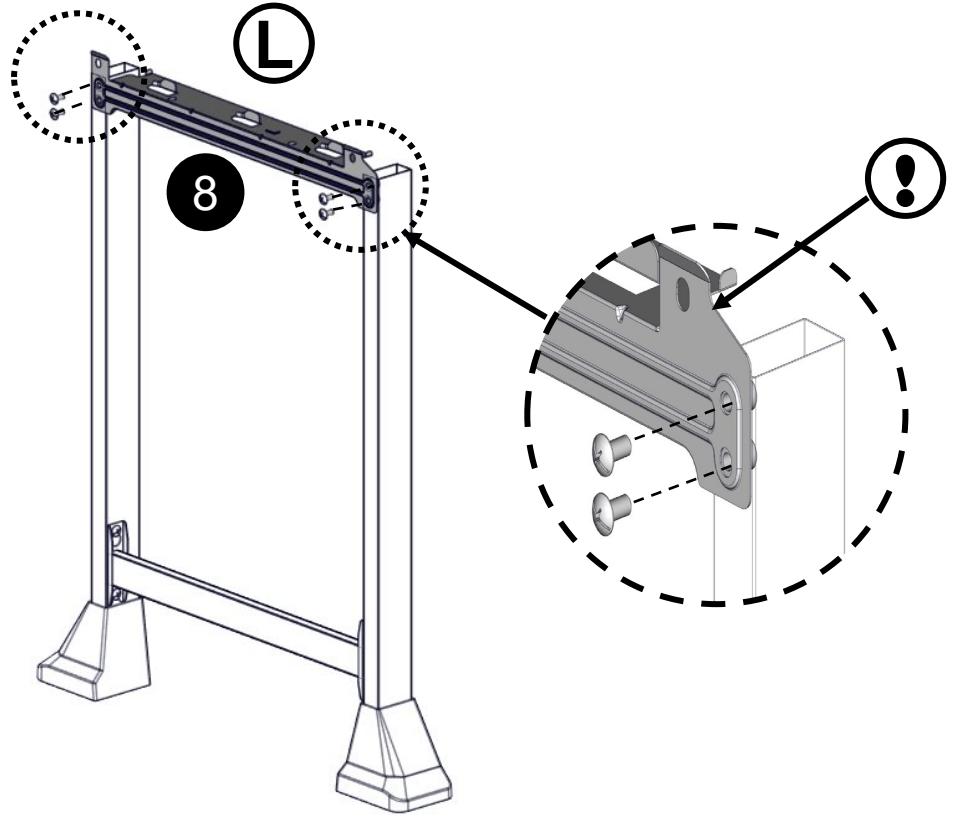
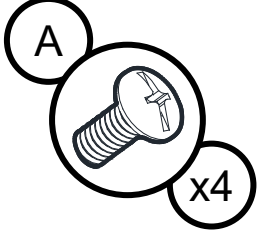

6 !

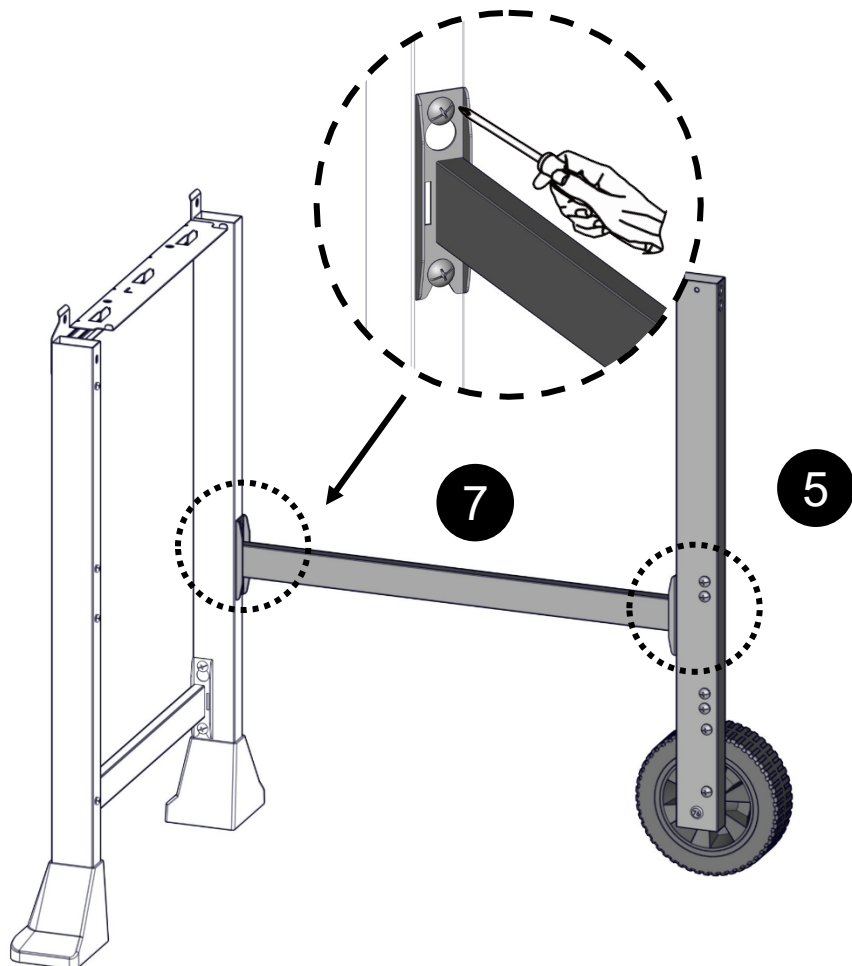

7

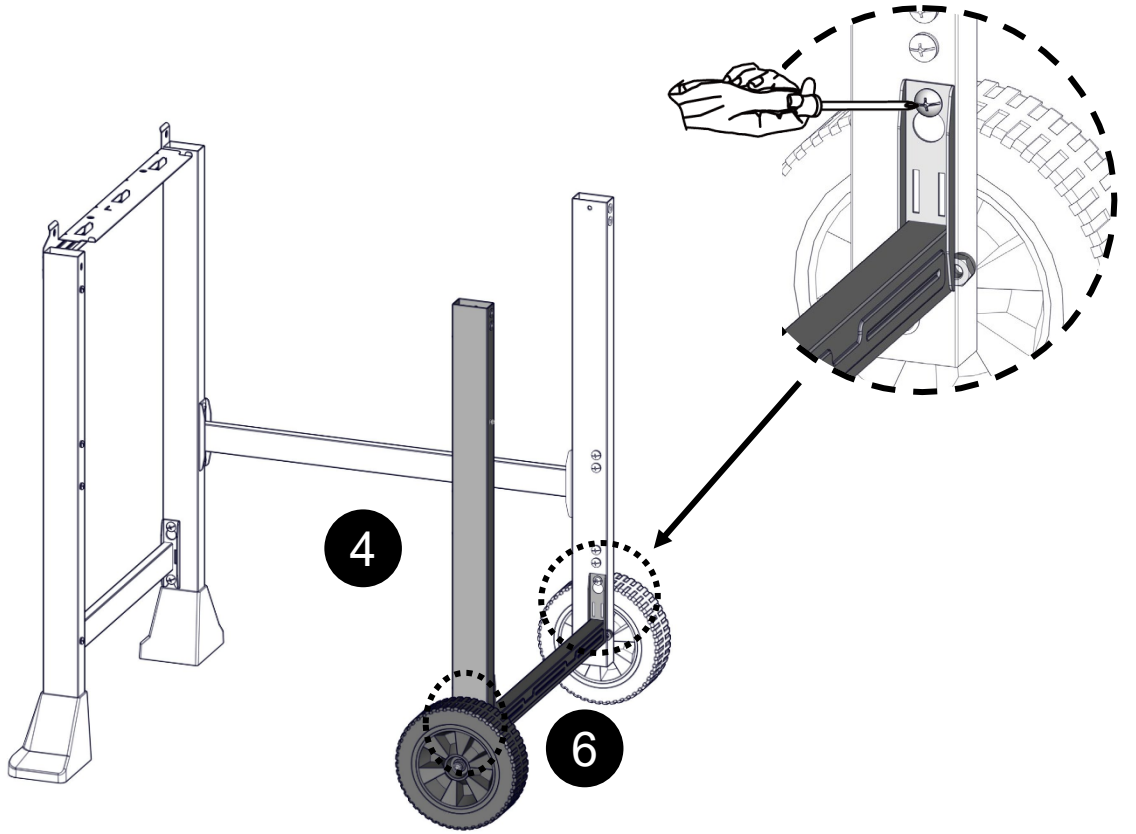

8

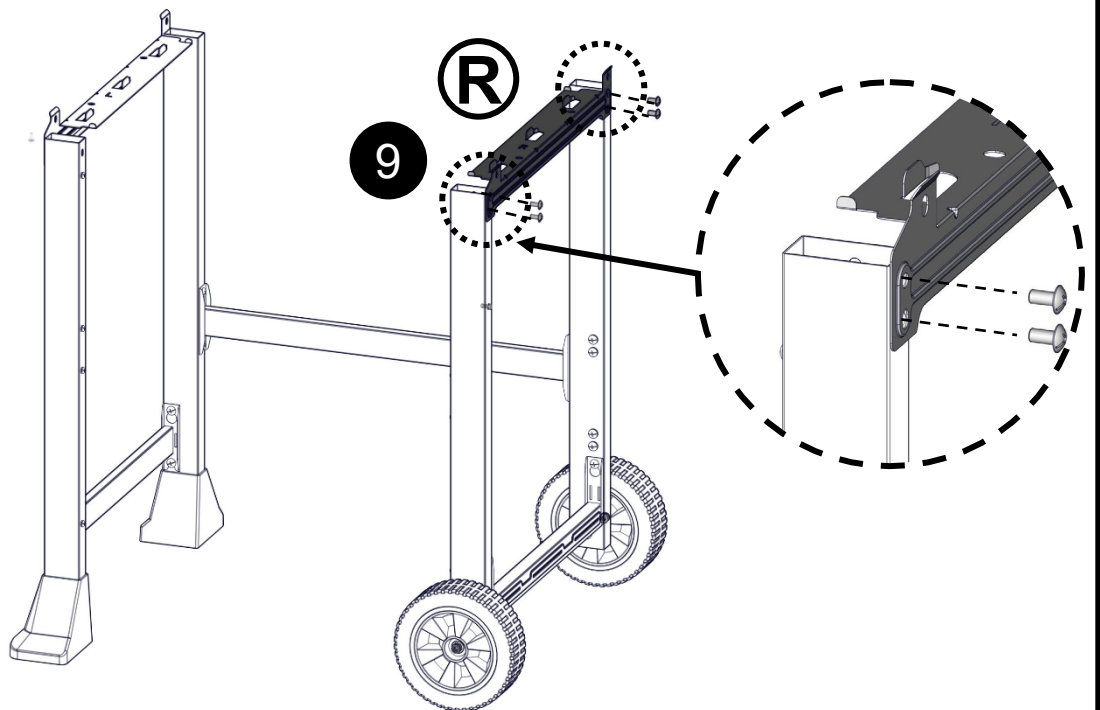
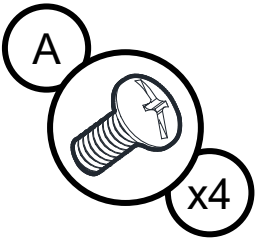

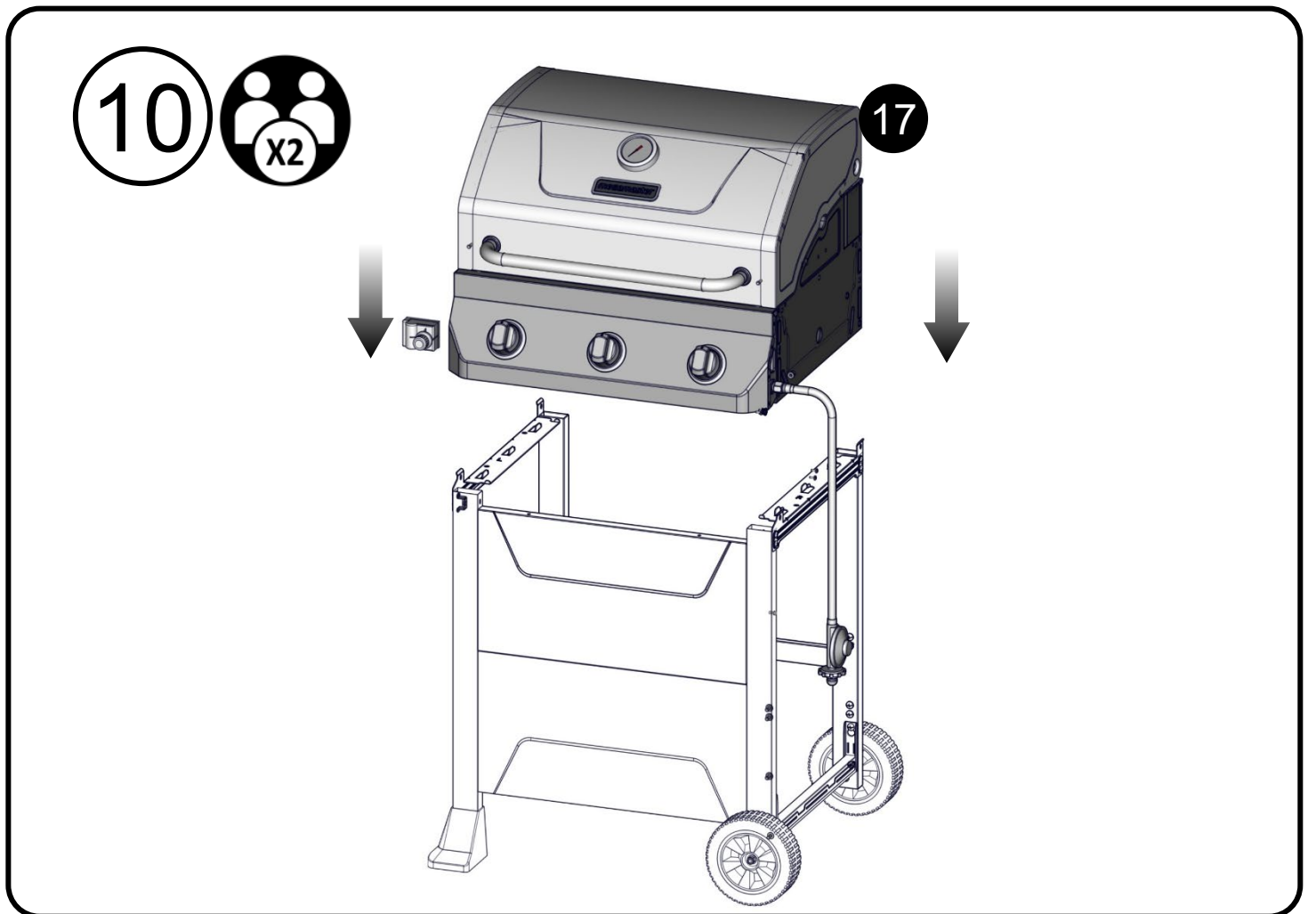
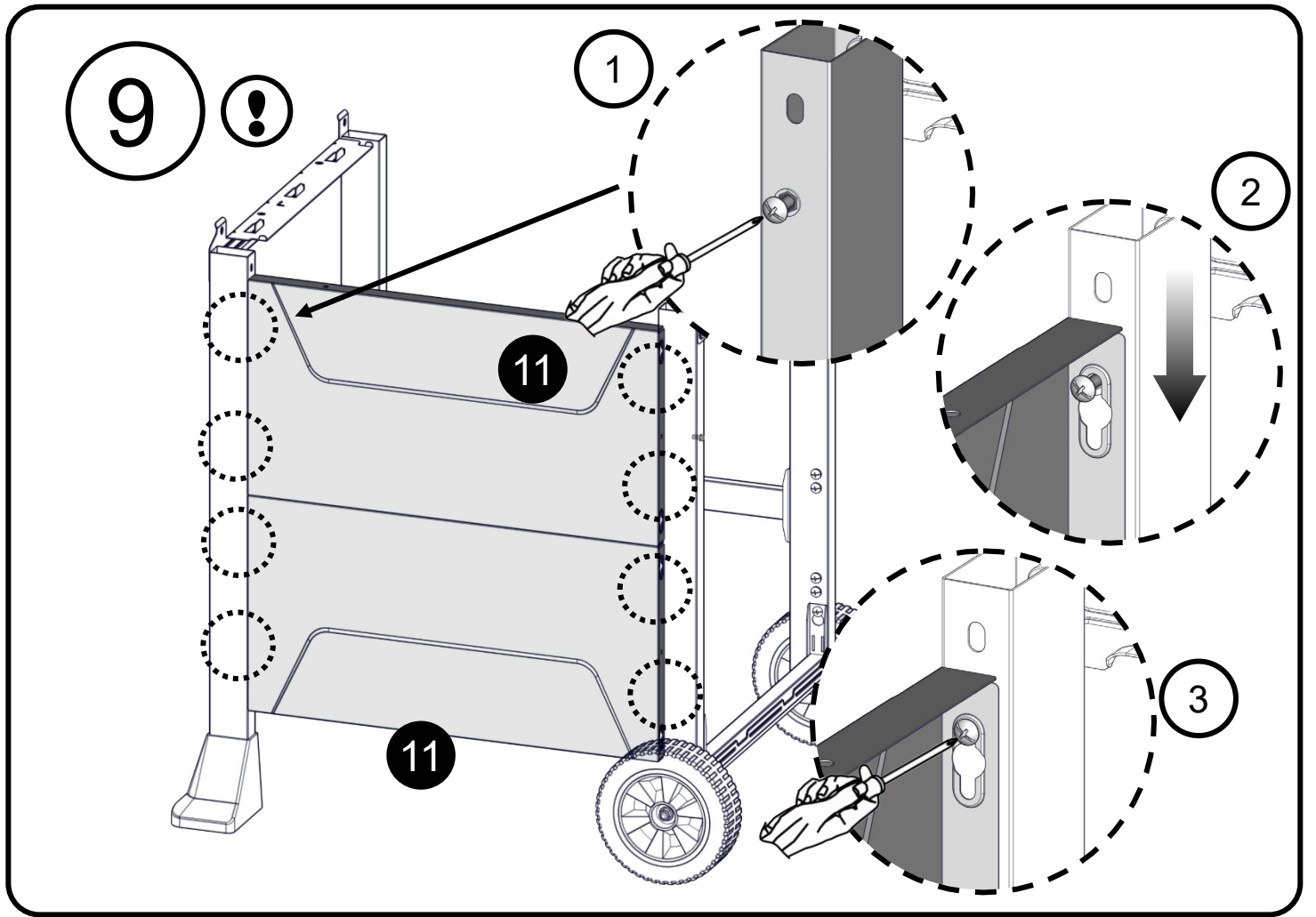

11

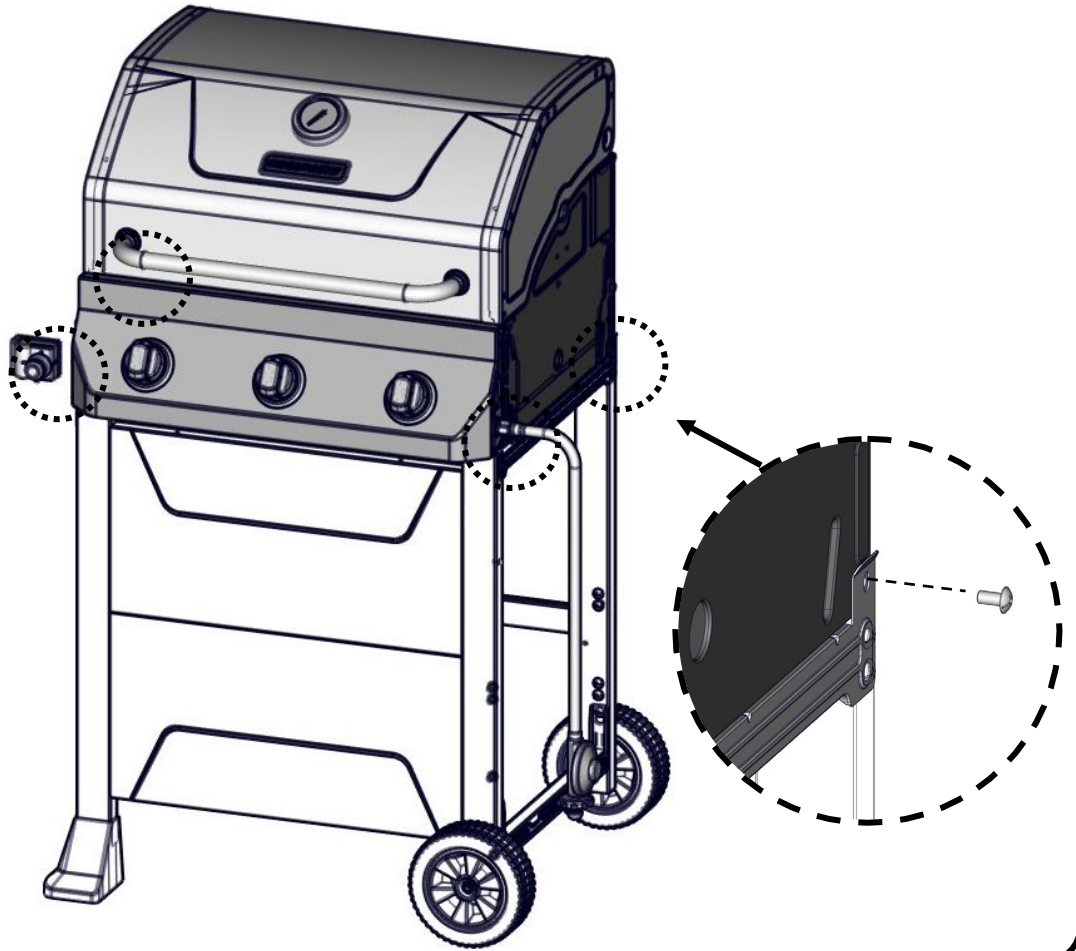
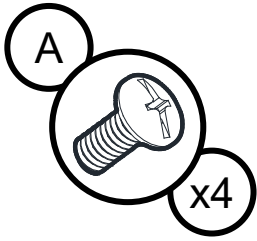

12

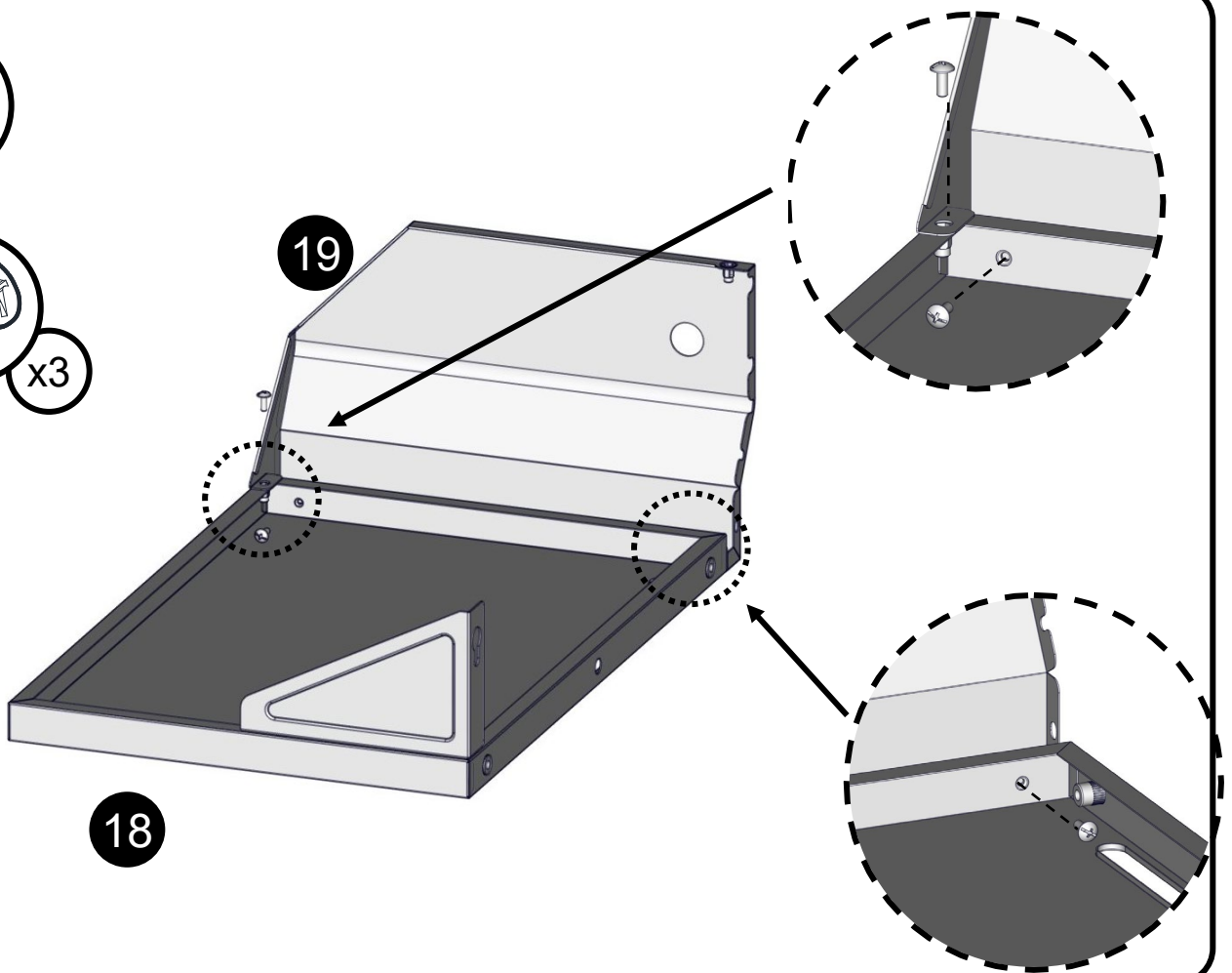
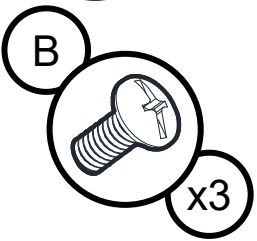

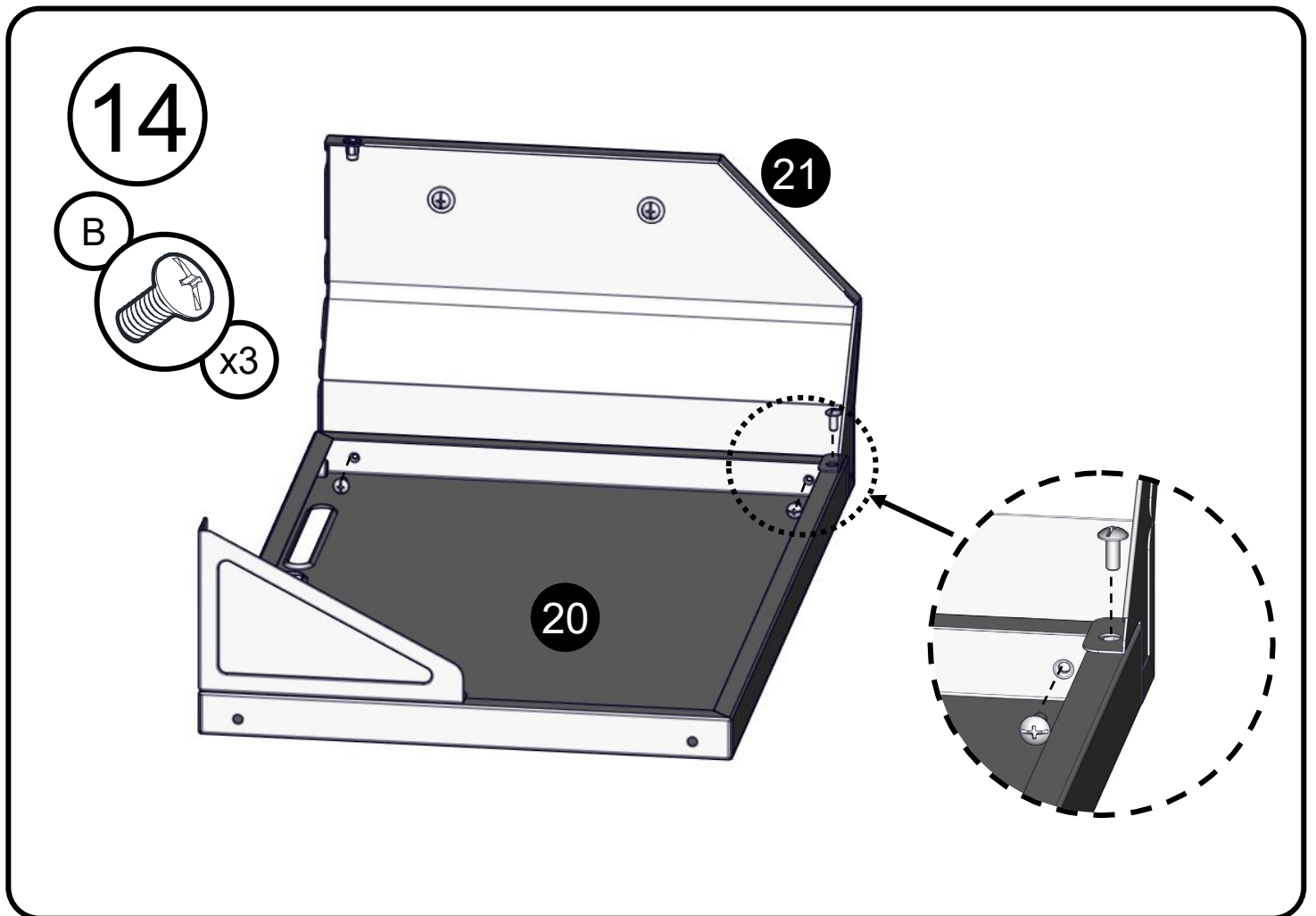
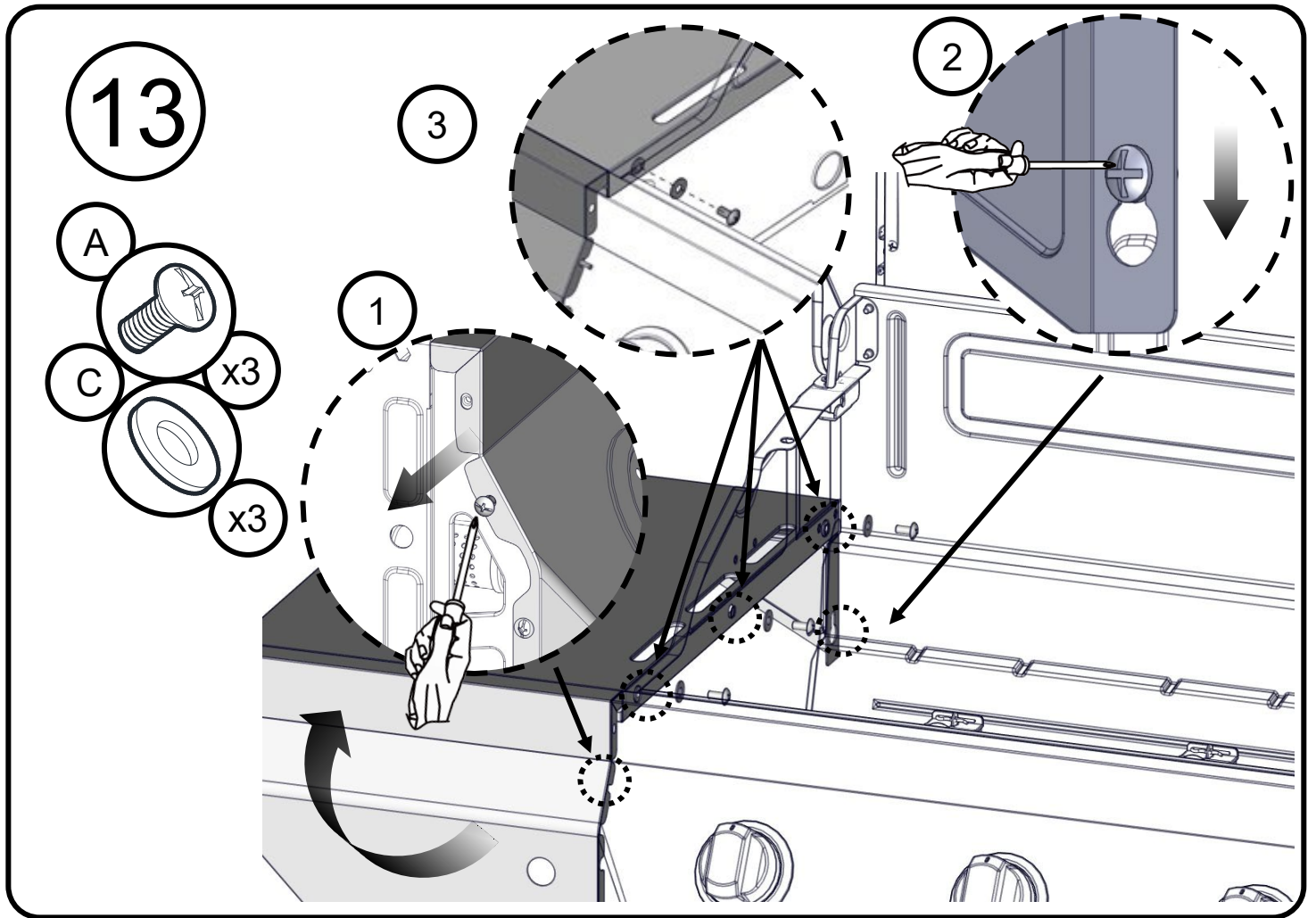

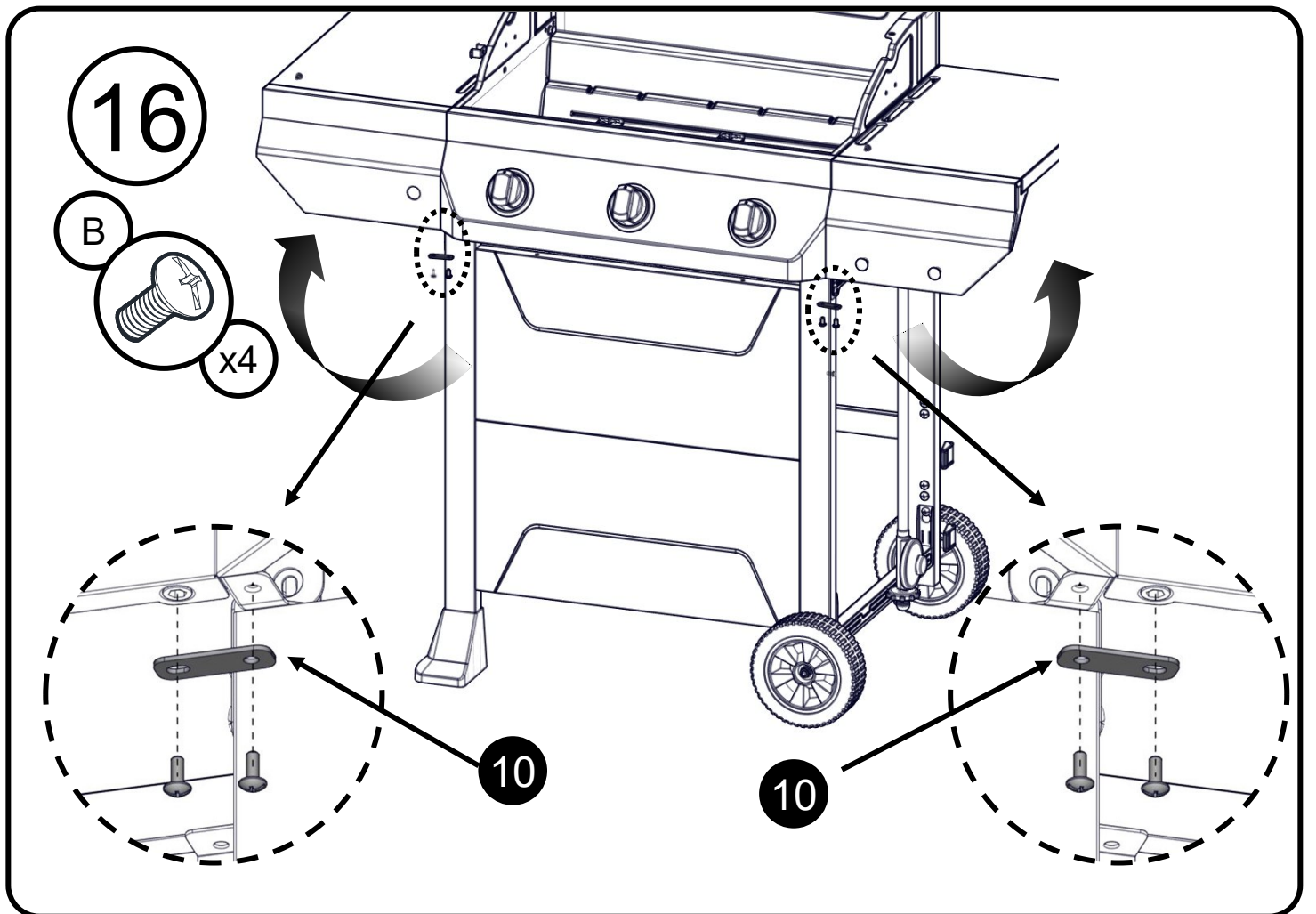
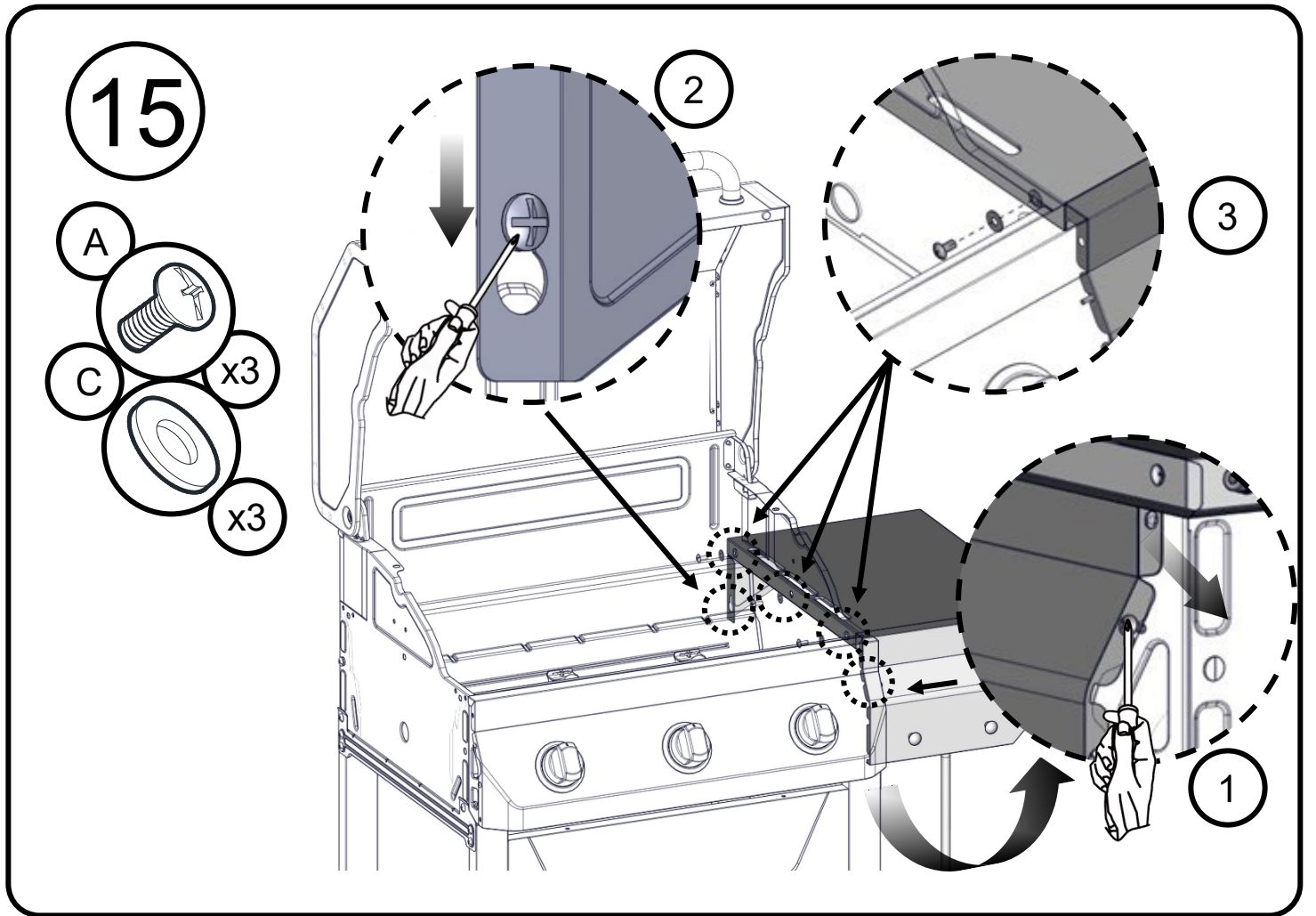

17

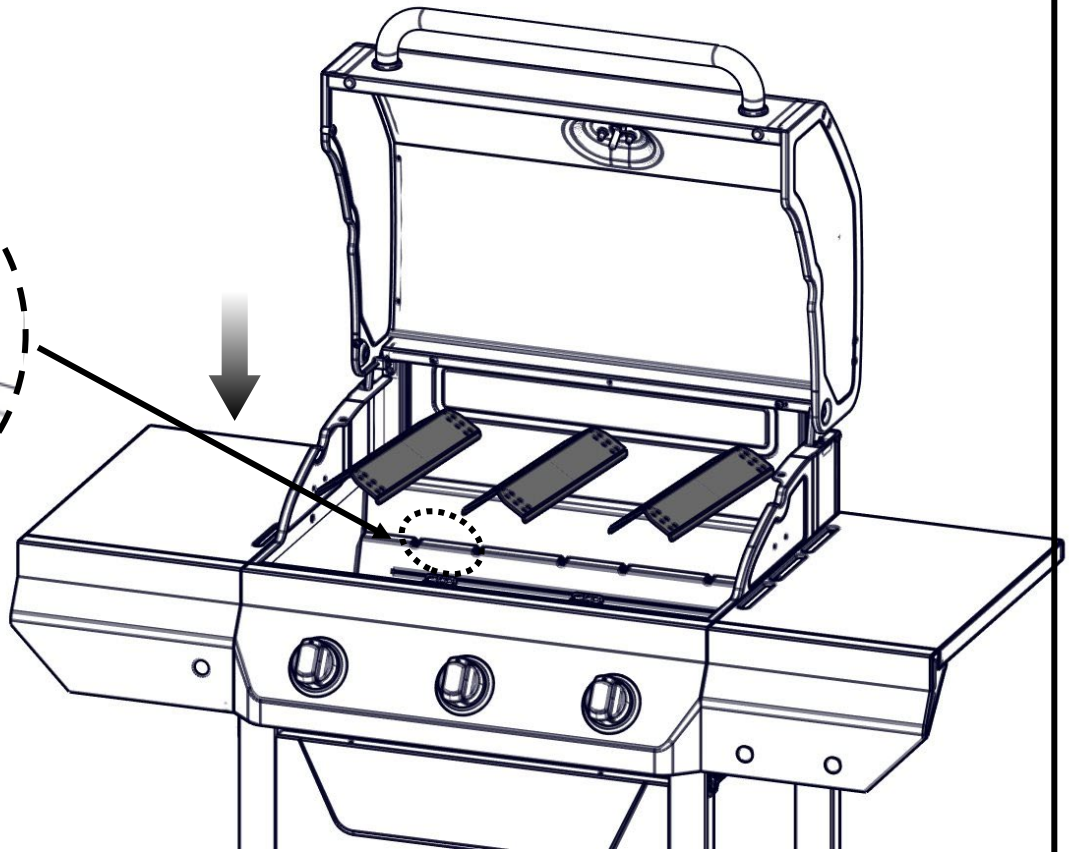
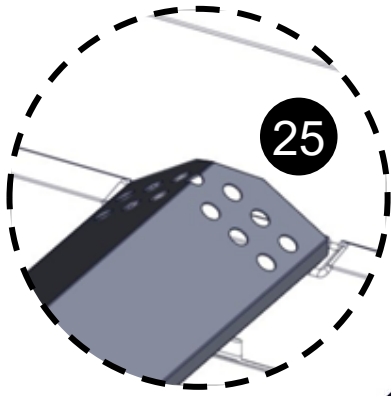

18

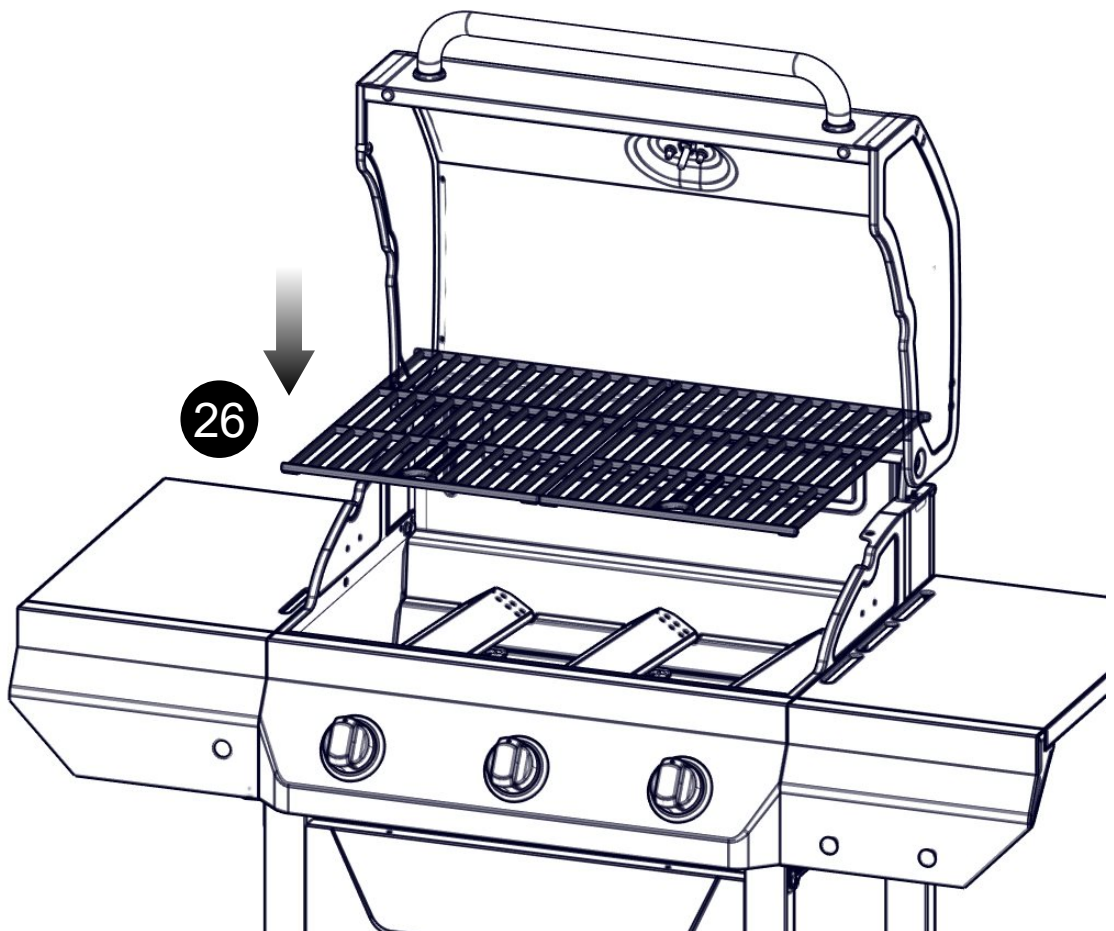

19

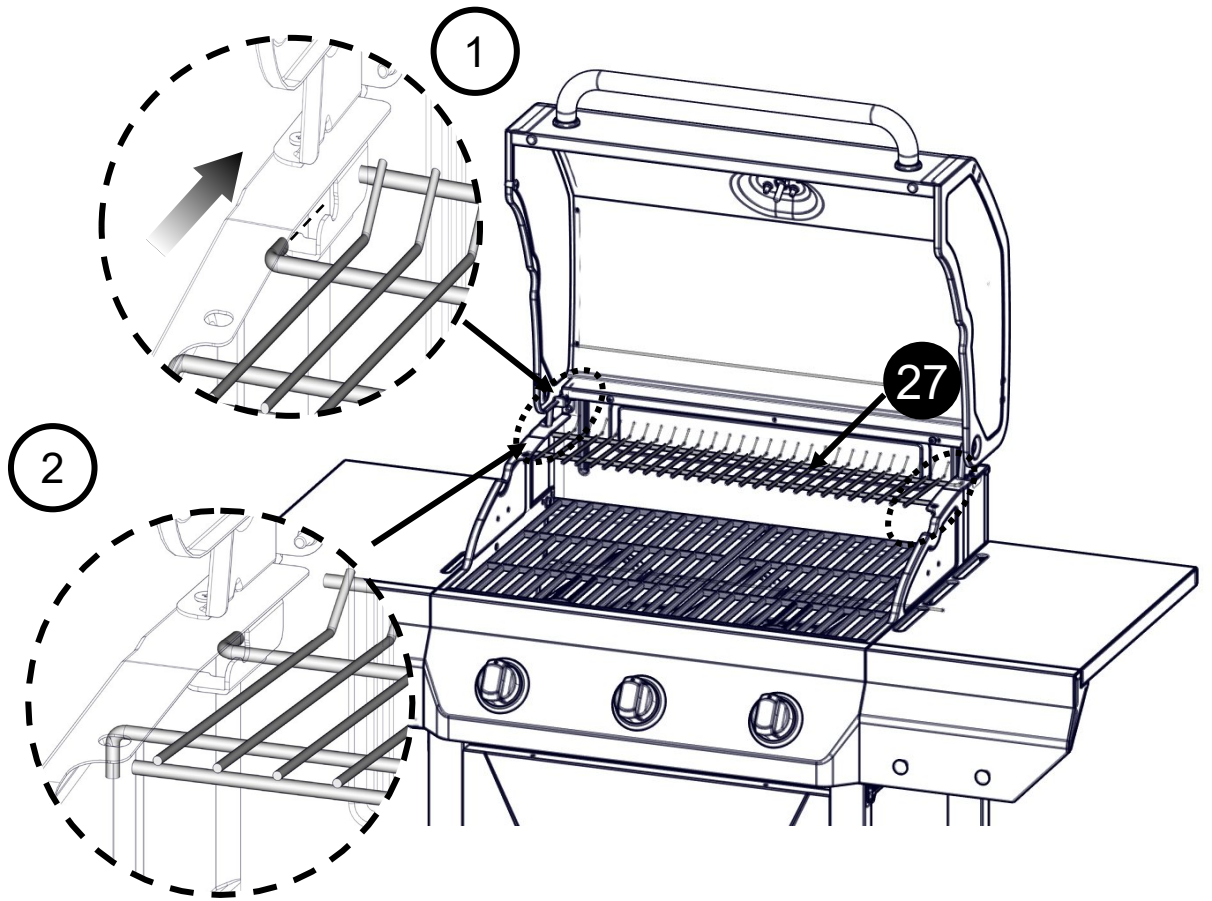

20

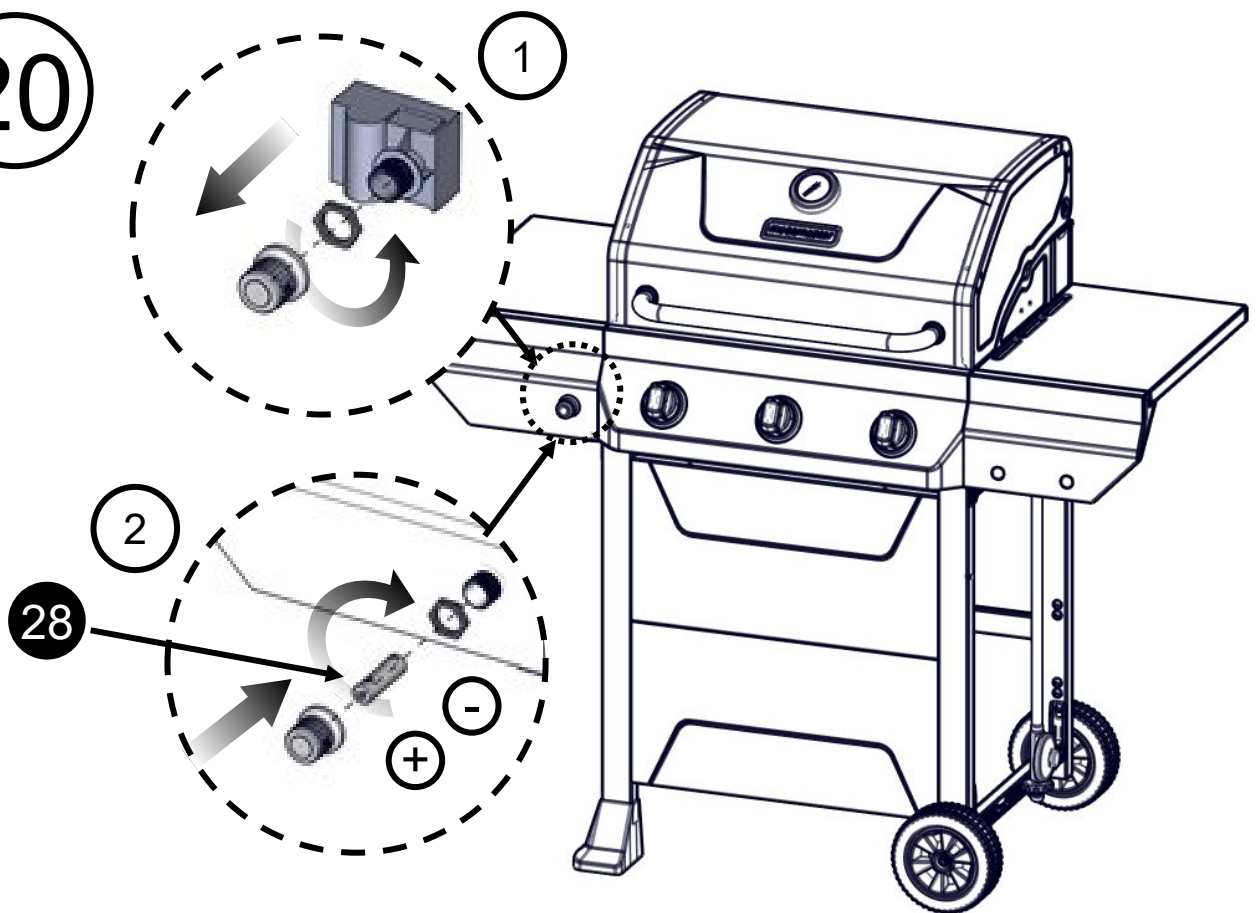

21

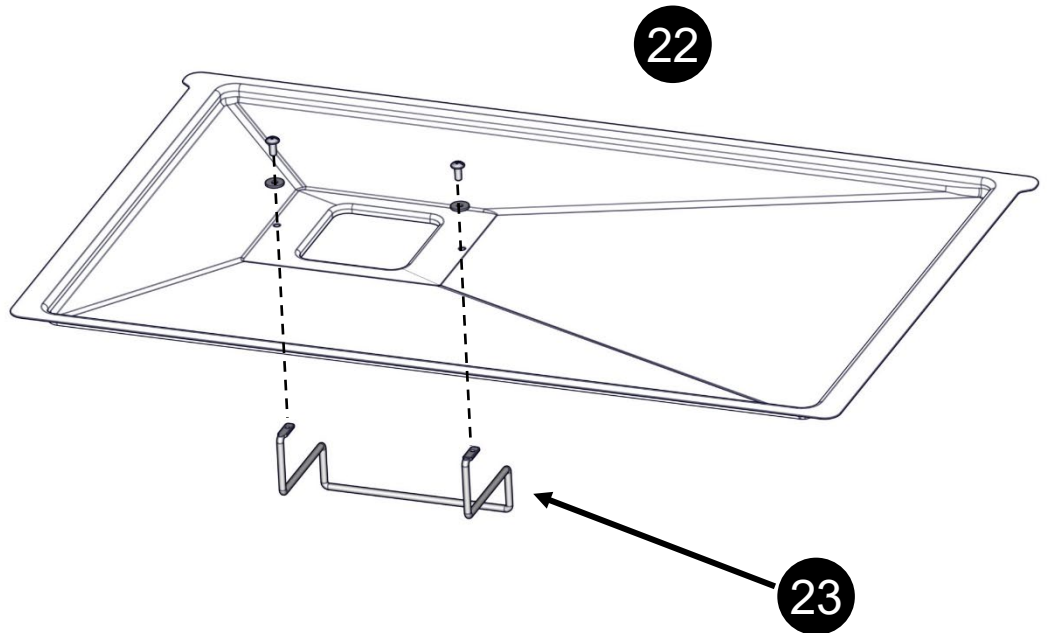
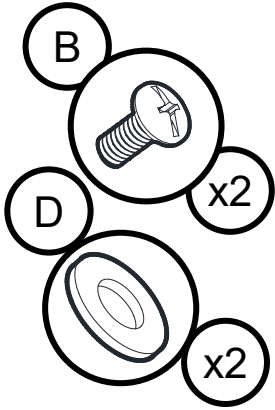

22

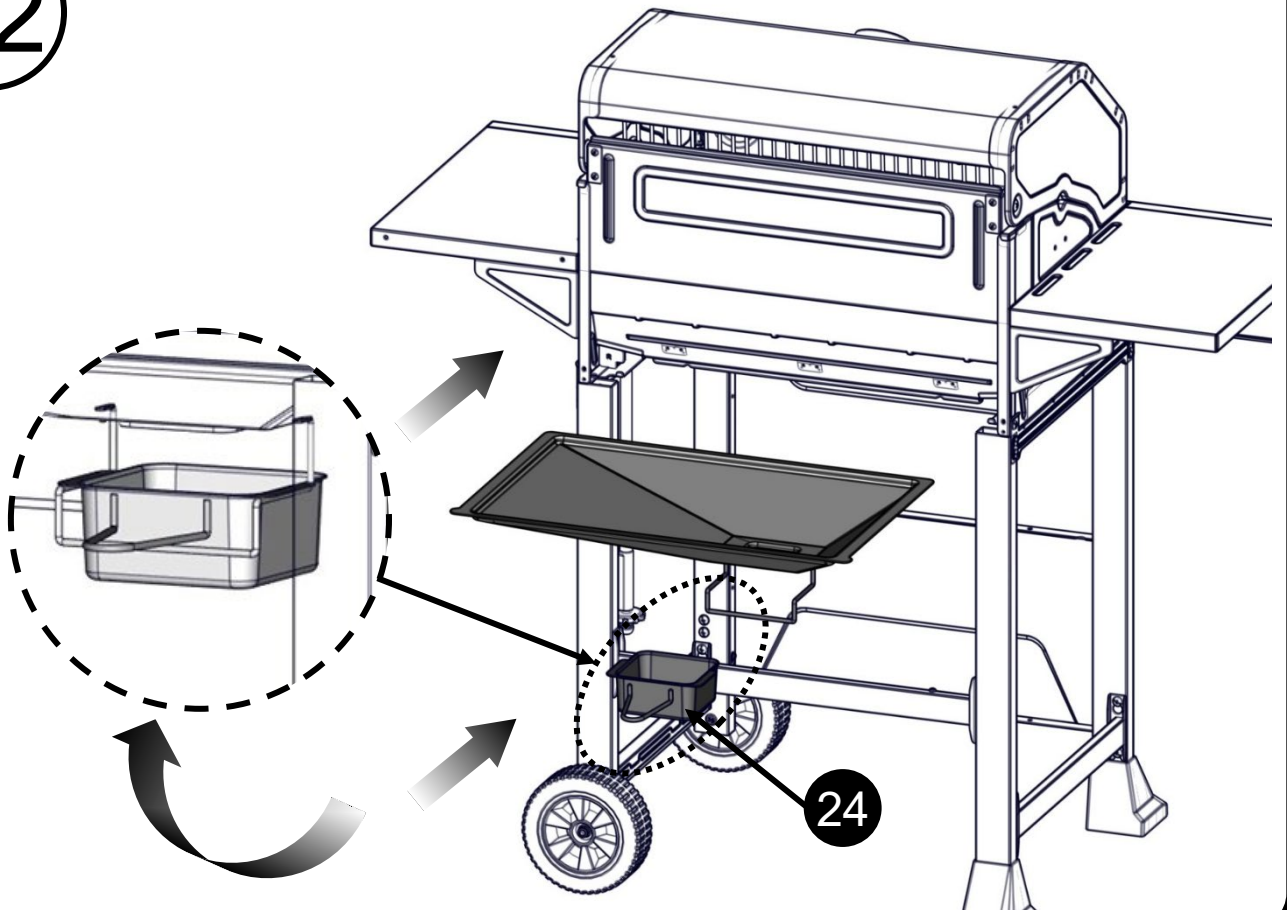

23 !

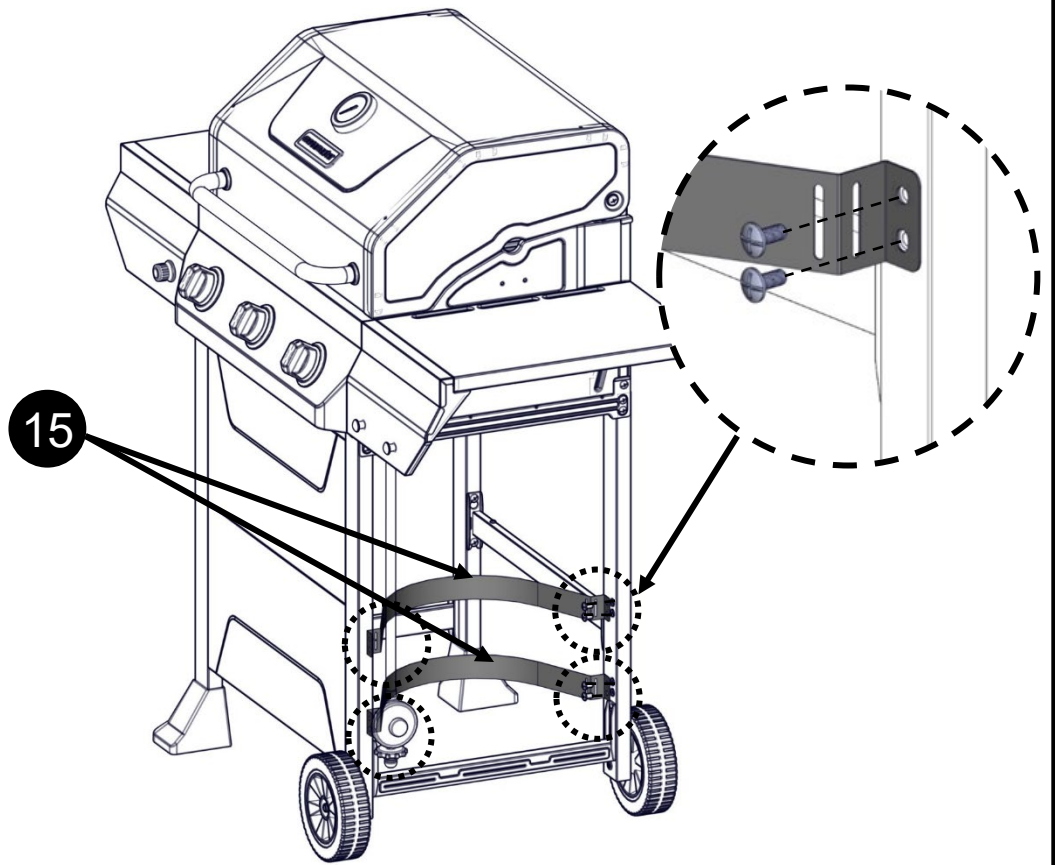
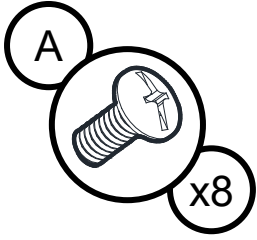

24 !

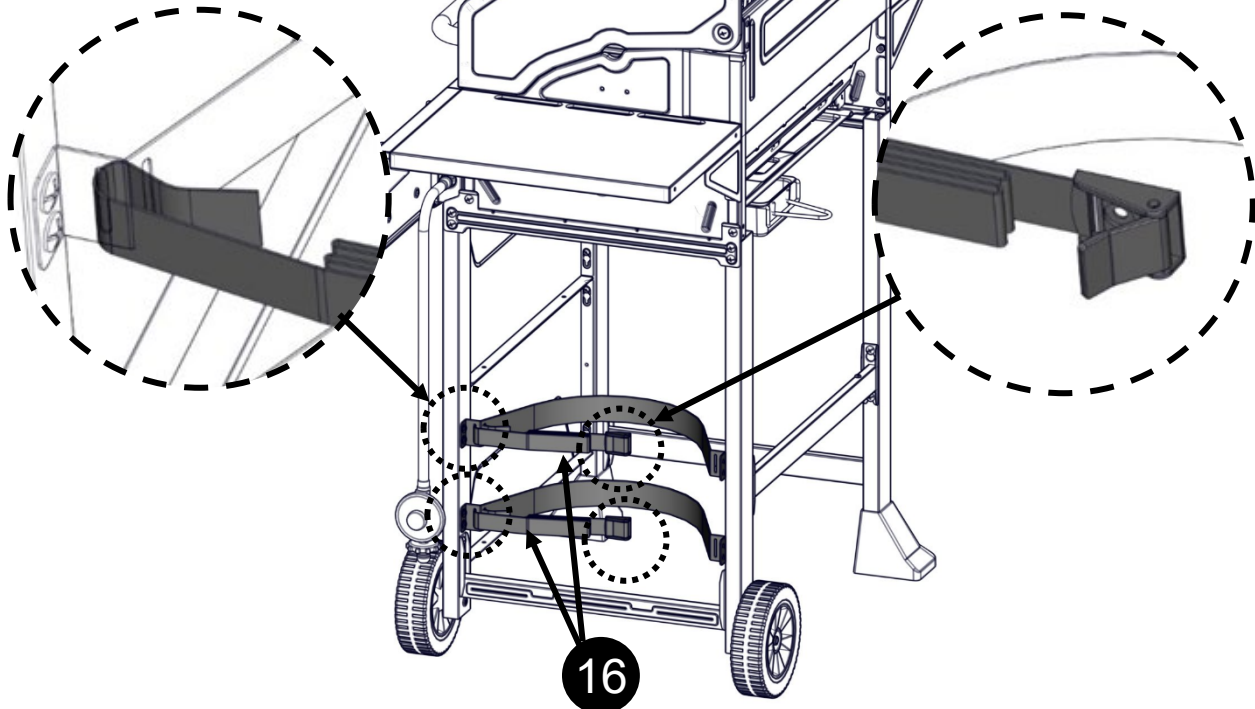

25 !

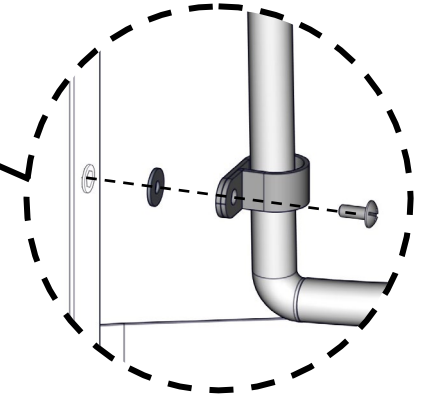
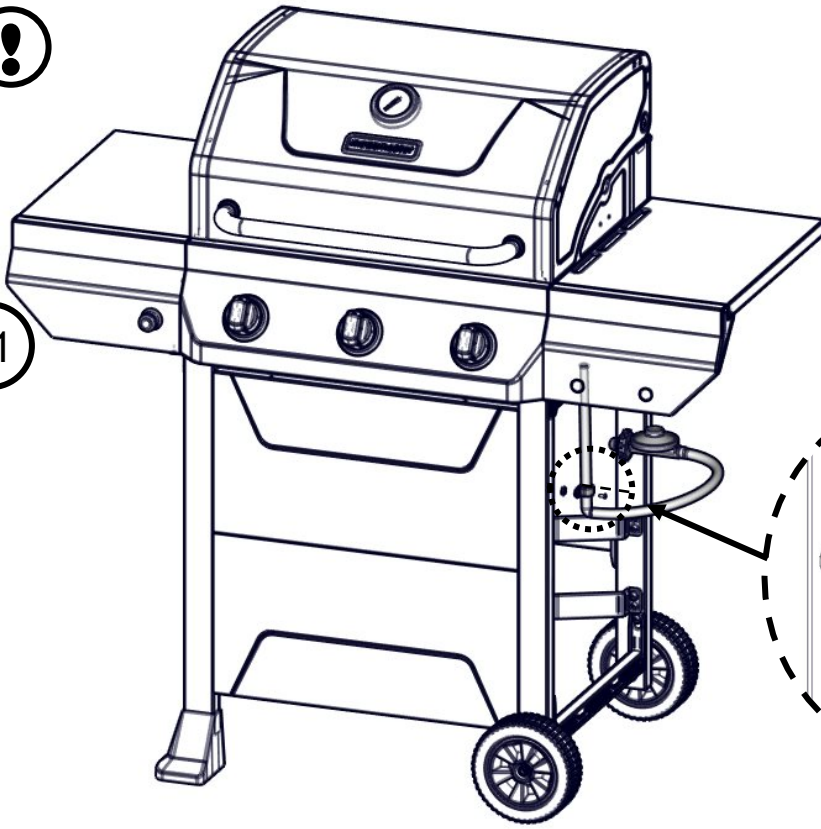
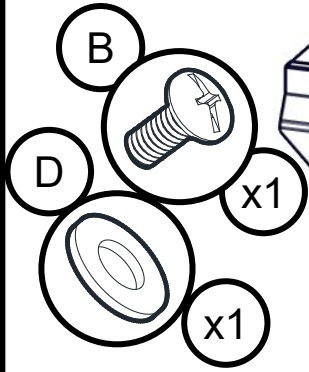

26

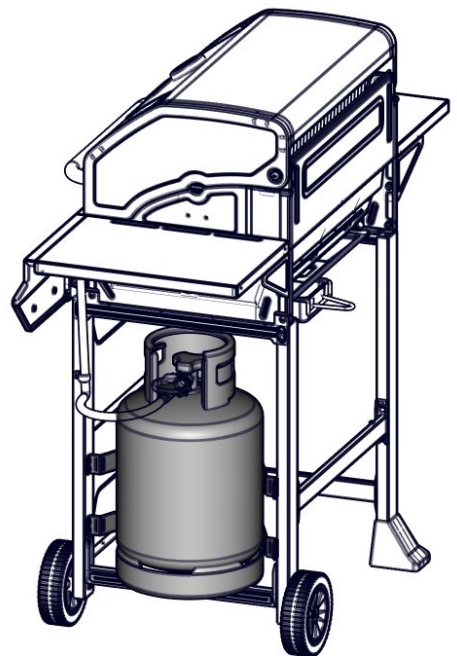
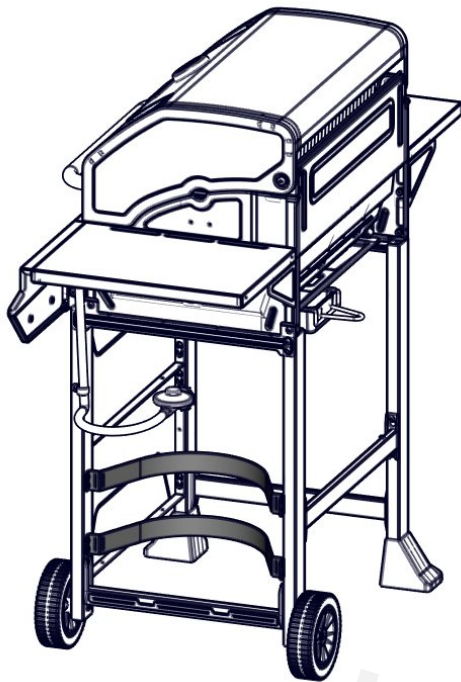
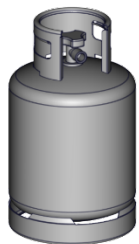

27

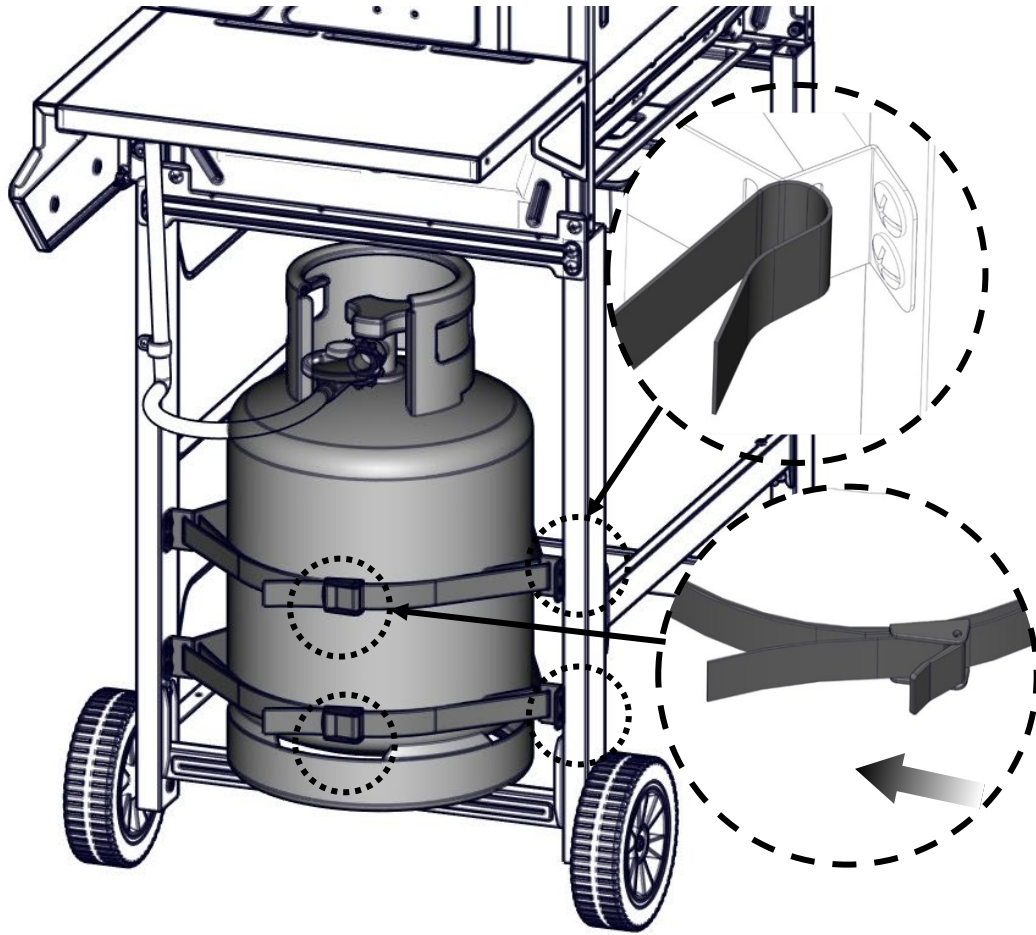

28

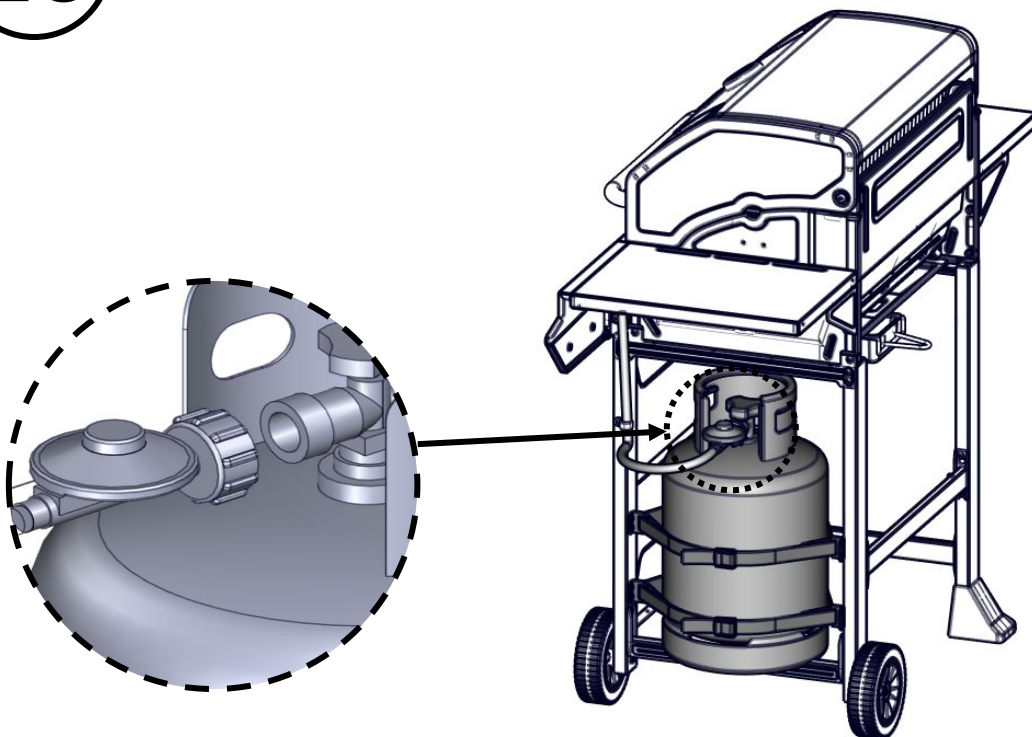

NEVER CONNECT AN UNREGULATED GAS SUPPLY LINE TO THE APPLIANCE. USE THE REGULATOR/HOSE ASSEMBLY SUPPLIED.

This is a LP Gas configured braai. Do not attempt to use a natural gas supply unless the braai has been reconfigured for natural gas use. Total gas consumption (per hour) of this gas braai with the burner on "HIGH":

Total Output – 40 500 Btu/hr.

L.P. CYLINDER REQUIREMENTS

A dented or rusty LP cylinder may be hazardous and should be checked by your LP Gas supplier. Never use a cylinder with a damaged valve. The LP gas cylinder must be constructed and marked in accordance with the specifications for LP Gas in South Africa. Spheres and tubes for transportation of dangerous goods; and commission, as applicable. Overfilling prevention device (OPD) shall be provided on cylinder & QCCI connection on the cylinder valve. The cylinder supply system must be arranged for vapour withdrawal. The cylinder must include a collar to protect the cylinder valve. The cylinder must be provided with a shut off valve terminal in an LP gas supply cylinder valve outlet specified, as applicable, for connection type QCC1 in the standard for compressed gas cylinder valve outlet and inlet connection.

L.P. GAS HOOK-UP

Ensure that the black plastic grommets or washers on the LP gas cylinder valve are in place and that the hose does not come in contact with the grease tray or the braai head.

Connection

Your patio gas braai is equipped with gas supply orifices for use only with LP gas. It is also equipped with a high-capacity hose/regulator assembly for connection to a standard 9kg LP gas cylinder (52cm high, 30cm diameter). To connect the LP gas supply cylinder, please follow the steps below:

1. Make sure cylinder valve is in the complete off position (turn clockwise to stop)
2. Check cylinder valve to ensure it has proper internal female threads .
3. Make sure all burner valves are in their off position.
4. Inspect valve connections, port, and regulator assembly. Look for any damage or debris. Remove any debris. Inspect hose for damage. Never attempt to use damaged or obstructed equipment. See your local LP gas Regulator Connections dealer for repair.
5. When connecting regulator assembly to the valve, hand tighten the wheel connection anti-clockwise to a complete stop. Do not use a wrench to tighten. Use of a wrench may damage the wheel and result in a hazardous condition.
6. Open the cylinder valve fully (counter-clockwise). Apply the soap solution with a clean brush to all gas connections. See below. If growing bubbles appear in the solution the connection is not properly sealed. Check each fitting and tighten or repair if necessary.
7. If you have a gas connection leak you cannot repair, turn gas OFF at supply cylinder, disconnect fuel line from your braai and call your gas supplier for repair assistance. In case of severe gas leaks or fire, contact your local fire department.
8. Also apply soapy solution to the cylinder seams. See below. If growing bubbles appear, shut cylinder OFF and do not use or move it! Contact an LP gas supplier or your fire department for assistance.

DISCONNECTING LP.GAS CYLINDER

1. Turn the burner valves off.
2. Turn the cylinder valve off fully (turn clockwise to stop).
3. Detach the regulator assembly from the cylinder valve by turning the wheel clockwise.

GENERAL

Although all gas connections on the braai are leak tested at the factory prior to shipment, a complete gas tightness check must be performed at the installation site due to possible mishandling in shipment, or excessive pressure unknowingly being applied to the unit. Periodically check the whole system for leaks following the procedures listed below. If the smell of gas is detected at anytime you should immediately check the entire system for leaks.

BEFORE TESTING

Make sure that all packing material is removed from the braai including tie-down straps.

DO NOT SMOKE WHILE LEAK TESTING. NEVER PERFORM LEAK TEST WITH AN OPEN FLAME.

Make a soap solution of one-part liquid detergent and one-part water. You will need a spray bottle, brush, or rag to apply the solution to the fittings.

TO TEST

1. Make sure the control valves are in the "OFF" position and turn on the gas supply.
2. Check all connections from the LP gas regulator and supply valve up to and including the connection to the manifold pipe assembly (the pipe that goes to the burners). Soap bubbles will appear where a leak is present.
3. Only those parts recommended by the manufacturer should be used on the braai.
4. Substitution will void the warranty. Do not use the braai until all connections have been checked and do not leak.

GAS FLOW CHECK

Each braai burner is tested and adjusted at the factory prior to shipment; however, variations in the local gas supply may make it necessary to adjust the burners. The flames of tips, excessive noise or lithe burners should be visually checked.

Flames should be blue and stable with no yellow. If any of these conditions exist, check to see if the air shutter or burner ports are blocked by dirt, debris, spider webs, etc. If you have any questions regarding flame stability, please call customer care.

ALWAYS CHECK FOR LEAKS AFTER EVERY LP GAS CYLINDER CHANGE

CHECK ALL GAS SUPPLY FITTINGS FOR LEAKS BEFORE EACH USE. IT IS HANDY TO KEEP A SPRAY BOTTLE OF SOAPY WATER NEAR THE SHUT-OFF VALVE OF THE GAS SUPPLY LINE. SPRAY ALL THE FITTINGS. BUBBLES INDICATE LEAKS.

INSTALLATION FINAL CHECKLIST

- ✓ Minimum clearance from the sides and back of the unit to combustible constructions is 36 in. (91cm) from the sides and 36 in. (91cm) from the back.
- ✓ All internal packaging removed.
- ✓ Knob turns freely.
- ✓ Burner is tight and sitting properly on orifice.
- ✓ Pressure regulator connected and set. Gas connections to braai using hose & regulator assembly provided for gas cylinder.
- ✓ Unit tested and free of leaks.
- ✓ User informed of gas supply shut off valve location.
- ✓ Removed all packaging, including straps, before using the braai.

WHEW,

We feel much better knowing you're safer for having taken the time to go through that first section thoroughly.

Now, let's get on with putting your Megamaster braai together so you can unleash your inner kebab/ pesto mushrooms / gourmet boerie roll rock star!

CAUTION: DO NOT LEAVE THE BRAAI UNATTENDED WHILE COOKING.

USING THE BRAAI

Each main burner is rated at 13 500 Btu/hr. The main braai burner encompasses the entire cooking area and are side ported to minimize blockage from falling grease and debris. The igniter knob are located on the lower center portion of the valve panel. Each rotary igniter is labeled on the control panel.

Braaiing requires high heat for searing and proper browning. Most foods are cooked at the “HIGH” heat setting for the entire cooking time. However, when braaiing large pieces of meat or poultry, it may be necessary to turn the heat to the lower setting after the initial browning. This cooks the food through without burning the outside. Foods cooked for a long time or foods basted with a sugary marinade may need the lower heat setting near the end of the cooking time.

NOTE: This braai unit is designed to cook efficiently without the use of lava rocks or briquettes of any kind. Heat is radiated by the flame tamer positioned above the burner.

NOTE: The hot braai sears the food, sealing in the juices. The more thoroughly the braai is preheated, the faster the meat browns and the darker the braai marks.

BEFORE LIGHTING THE BRAAI

Inspect the gas supply hose prior to turning the gas “ON”. If there is evidence of cuts, wear, or abrasion, it must be replaced prior to use. Do not use the braai if the odour of gas is present. Do not use any other hose connection other than the regulator hose assembly that came with the unit.

Never substitute regulators and hose assembly for those supplied with the braai. If a replacement is necessary, contact the manufacturer for proper replacement. The replacement must be specified in the owner’s manual.

WARNING: Always keep your face and body as far away from the burner as possible when lighting.

FLAME CHARACTERISTICS

1. Check for proper burner flame characteristics.
2. Burner flames should be blue and stable with no yellow tips, excessive noise, or lifting. If any of these conditions exist call our customer service line. If the flame is yellow, this is an indication of insufficient air. If the flame is noisy and tends to lift away from the burner, this is an indication of excessive oxygen.
3. Visually check the burner flames prior to each use, The flames should look like the image below. If they do not, refer to the burner maintenance part of this manual.

KNOB OPERATION



1. Open lid during lighting. Make sure the propane cylinder is tightly threaded into the regulator (hand-tighten only). Make sure all the knobs are in the “OFF” position, and then
2. Turn the Liquid Propane Cylinder valve “ON” by slowly turning counterclockwise. Push and turn Main Burner control knob to IGNITE/HIGH or
3. IGNITE/ON, at the same time, press and hold control knob to light the burner, with the electronic ignition.
4. Once the burner is lit, release the knob.
5. If ignition does not occur in 5 seconds, turn the knob to OFF, wait 5 minutes and repeat the lighting procedure.

NOTE: Each burner is adjusted prior to shipment; however, variations in the local gas supply may make minor adjustments necessary. Oxygen setting can be adjusted by using the screw located on the top of the burner near the orifice connection. Turn the screw using a star-screwdriver until the flame quality is acceptable.

BRAAI GRATE

The easiest way to clean the braai is immediately after cooking is completed and after turning off the flame. Wear an oven mitt to protect your hand from the heat and steam. Dip a brass bristle barbeque brush in water and scrub the hot braai. Dip the brush frequently in the bowl of water. Steam, created as water contacts the hot braai, assists the cleaning process by softening any food particles. If the braai is allowed to cool before cleaning, cleaning will be more difficult.

CAUTION: ENSURE THAT THE GAS SUPPLY AND THE KNOBS ARE IN THE “OFF” POSITION. MAKE SURE THE RANGETOP BURNER IS COOL BEFORE REMOVAL.

BRAAI BURNERS

Extreme care should be taken when moving a burner as it must be correctly centered on the orifice before any attempt is made to relight the braai. Frequency of cleaning will depend on how often you use the braai.

BRAAI BURNER CLEANING

Ensure the gas supply is off and the knobs are in the “OFF” position. Make sure the braai is cool. Clean the exterior of the burner with a wire brush. Remove excessive build up with a metal scraper. Clear any clogged ports with a straightened paper clip. Never use a wooden toothpick as it may break off and clog the port. If insects or other obstructions are blocking the flow of gas through the burner, you will need to call our customer care.

1. Turn off the gas supply, and make sure all the knobs are in the “OFF” position.
2. Wait for the braai to cool.
3. Clean the exterior of the burner with a wire brush. Use a metal scraper for stubborn stains.
4. Clear clogged port with a straightened paper clip. Never use a wooden toothpick as it may break off and clog the port.
5. If inserts or other obstructions are blocking the flow of gas through the burner, call customer care.

GREASE TRAY CLEANING

The grease tray should be emptied and wiped down periodically and washed with a mild detergent and warm water solution. A small amount of sand may be placed in the bottom of the grease tray to absorb the grease. Check the grease tray frequently, do not allow excess grease to accumulate and overflow out of the grease tray.

PROBLEM	SOLUTION
<p>When attempting to light my braai, it will not light immediately.</p>	<p>Make sure you have a spark while you are trying to light the burner (if no spark). Ensure that the wire is connected to the electrode assembly. Clean wire (s) and / or electrode with rubbing alcohol and a clean swab. Wipe with a clean cloth. Check to see if the other burners operate. If so. Check the gas orifice on the malfunctioning burner for an obstruction.</p>
<p>Regulator makes noise.</p>	<p>Vent hose on the regulator may be plugged or regulator may be faulty. Ensure the vent hole on the regulator is not obstructed. Clear the hole, close the gas control valves. Wait ten minutes and re-start. Check your flames for proper performance. If the flames are not correct, replace regulator.</p>
<p>braai only heats to 200-300 degrees.</p>	<p>Check to see if the fuel hose is bent or kinked. Make sure the braai area is clear of dust. Make sure the burner and orifices are clean. Check for spiders and insects. The regulator has a safety device that restricts the flow of gas in the event of a leak. This safety device can be triggered without a gas leak. To reset the safety device, turn off all burners and close the LP tank valve. Disconnect the regulator from the LP tank and wait one minute. Reconnect the regulator to the LP tank and slowly open the LP tank valve until the valve is fully open. Light all burners and observe the temperature.</p>
<p>braai takes a long time to preheat.</p>	<p>Normal preheat 250-300 degrees, takes about 10-15 min. Cold weather and wind may effect your preheat time. If you are using volcanic rock or briquettes they can increase the preheat time and maximum temperature.</p>
<p>Burner flames are not light blue.</p>	<p>Too much or not enough air for the flame. Elevation is the principal cause, however cold weather can affect the mixture. Burner adjustment may be required. braai is in a windy location.</p>

WARNING: If you wish to replace the main burner, we strongly recommend that you hire a professionally trained technician to replace it. Please understand that we will not be responsible for any liability, personal injury, or property damage resulting from an improperly assembled burner.

HOW TO REPLACE THE MAIN BURNER

1. Remove the main burner “R” pin on the back wall of fire box by using needle nose pliers. Use a flathead screwdriver to remove burner pin cover, then remove the burner on the front wall of fire box, as shown below.
2. Insert the burner onto the orifice and secure the burner pin cover on the burner, as shown below, making sure burner hole aim at orifice.
3. Secure the main burner on the back wall of fire box with “R” Pin.

HOW TO ORDER REPLACEMENT PARTS

To make sure you obtain the correct replacement part (s) for your gas braai, please refer to the parts list at the end of the manual. The following information is required to assure getting the correct part. Please note the shipping cost for the delivery of any replacement parts will be on yourself.

- Gas braais model number (see data sticker on braai).
- Part number of replacement part needed.
- Description of replacement part needed.
- Quantity of parts needed.

To obtain replacement parts, contact our Customer Service hotline at **012 802 1515**

WARRANTY



The manufacturer warrants to the original consumer-purchaser only that this product **Megamaster Pinnacle Series Stainless Steel 3 Burner Patio Gas Braai (Model #720-0925SD)** shall be free from defects in workmanship and materials after correct assembly and under normal and reasonable home use for the periods indicated below beginning on the date of purchase. The manufacturer reserves the right to require photographic evidence of damage, or that defective parts be returned, postage and/or freight pre-paid by the consumer, for review and examination. Megamaster obligation is limited to repair, replacement, or depreciated value, at the option of Megamaster.

- **TUBE BURNERS:** 1 year *LIMITED* warranty against perforation.
- **COOKING GRIDS and FLAME TAMERS:** 1 year *LIMITED* warranty; *does not cover dropping, chipping, scratching, or surface damage.*
- **STAINLESS STEEL PARTS:** 1 year *LIMITED* warranty against perforation; *does not cover cosmetic issues like surface corrosion, scratches and rust.*
- **ALL OTHER PARTS:** 1 year *LIMITED* warranty (Includes, but not limited to, valves, frame, housing, cart, control panel, igniter, regulator, hoses) **Does not cover chipping, scratching, cracking surface corrosion, scratches or rust.*

Upon consumer supplying proof of purchase as provided herein, Manufacturer will repair or replace the parts which are proven defective during the applicable warranty period. Parts required to complete such repair or replacement shall be free of charge to you except for shipping costs, as long as the purchaser is within the warranty period from the original date of purchase. Reasonable proof of your date of purchase. The original consumer-purchaser will be responsible for all shipping charges of parts replaced under the terms of this limited warranty. This limited warranty is applicable in South Africa only, is only available to the original owner of the product and is not transferable. Manufacturer requires, you should retain your sales receipt and/or invoice. If the unit was received as a gift, please ask the gift-giver to send in the receipt on your behalf, to the below address. Defective or missing parts subject to this limited warranty will not be replaced without registration or proof of purchase. Missing parts needs to be reported within 7 days of purchase. This limited warranty applies to the functionality of the product **ONLY** and does not cover cosmetic issues such as scratches, dents, corruptions or discoloring by heat, abrasive and chemical cleaners or any tools used in the assembly or installation of the appliance, surface rust, or the discoloration of stainless steel surfaces. Surface rust, corrosion, or powder paint chipping on metal parts that does not affect the structural integrity of the product is not considered a defect in workmanship or material and is not covered by this warranty. This limited warranty will not reimburse you for the cost of any inconvenience, food, personal injury or property damage. If an original replacement part is not available, a comparable replacement part will be sent. You will be responsible for all shipping charges of parts replaced under the terms of this limited warranty.

MANUFACTURER WILL NOT PAY FOR:

- Service calls to your home.
- Repairs when your product is used for other than normal, single-family household or residential use.
- Damage resulting from accident, alteration, misuse, lack of maintenance/cleaning, abuse, fire, flood, acts of God, improper installation, and installation not in accordance with electrical or plumbing codes or misuse of product.
- Any food loss due to product failures.
- Replacement parts or repair labor costs for units operated outside South Africa.
- Pickup and delivery of your product.
- Postage fees or photo processing fees for photos sent in as documentation.
- Repairs to parts or systems resulting from unauthorized modifications made to the product.
- The removal and/or reinstallation of your product.
- Shipping cost, standard or expedited, for warranty/non warranty and replacement parts.

DISCLAIMER OF IMPLIED WARRANTIES: LIMITATION OF REMEDIES

Repair or replacement of defective parts is your exclusive remedy under the terms of this limited warranty. Manufacturer will not be responsible for any consequential or incidental damages arising from the breach of either this limited warranty or any applicable implied warranty, or for failure or damage resulting from acts of God, improper care and maintenance, grease fire, accident, alteration, replacement of parts by anyone other than manufacturer, misuse, transportation, commercial use, abuse, hostile environments (inclement weather, acts of nature, animal tampering), improper installation or installation not in accordance with local codes or printed manufacturer instructions.

THIS LIMITED WARRANTY IS THE SOLE EXPRESS WARRANTY GIVEN BY THE MANUFACTURER. NO PRODUCT PERFORMANCE SPECIFICATION OR DESCRIPTION WHEREVER APPEARING IS WARRANTED BY MANUFACTURER EXCEPT TO THE EXTENT SET FORTH IN THIS LIMITED WARRANTY. ANY IMPLIED WARRANTY PROTECTION ARISING UNDER THE LAWS OF ANY STATE, INCLUDING IMPLIED WARRANTY OF MERCHANTABILITY OR FITNESS FOR A PARTICULAR PURPOSE OR USE, IS HEREBY LIMITED IN DURATION TO THE DURATION OF THIS LIMITED WARRANTY.

Neither dealers nor the retail establishment selling this product has any authority to make any additional warranties or to promise remedies in addition to or inconsistent with those stated above. Manufacturer's maximum liability, in any event, shall not exceed the documented purchase price of the product paid by the original consumer. This warranty only applies to units purchased from an authorized retailer and or re-seller.

If you wish to obtain performance of any obligation under this limited warranty, you should write to:

Megamaster Customer Service

PO Box 15, Woodlands, 0072, South Africa

All consumer returns, parts orders, general questions, and troubleshooting

assistance can be acquired by calling 012 802 1515 or sending an e-mail to service@megagroup.co.za

THANK YOU.

You are now a Megamaster manual pro!
Get out there and enjoy making your braaing
experience even better.

For great inspiration and recipes to use your braai, check out
the recipe pages on our website www.megamaster.co.za

Finally, don't forget to keep this manual in a safe place for
future reference.