

LING

DESIGNED BY METRICA

ASSEMBLY INSTRUCTIONS





DISCLAIMER

THE ASSEMBLY INSTRUCTIONS ARE TO BE USED AS A GUIDE SHOWING THE GENERAL ASSEMBLY OF THE PRODUCT. IT WILL NOT BE IDENTICAL TO THE PRODUCT YOU HAVE PURCHASED.

ENSURE THAT ALL STEPS ARE FOLLOWED IN THE CORRECT ORDER AND THAT NO STEP IS LEFT OUT.
A MINIMUM OF TWO PEOPLE ARE REQUIRED FOR ASSEMBLY.

TO PREVENT ANY DAMAGE OF THE PRODUCT, DO NOT USE A BOX CUTTER, KNIFE OR SHARP OBJECT TO OPEN THE BOXES.

LING

PACKAGING
PARTS

BOX WITH WOOD STRUCTURE

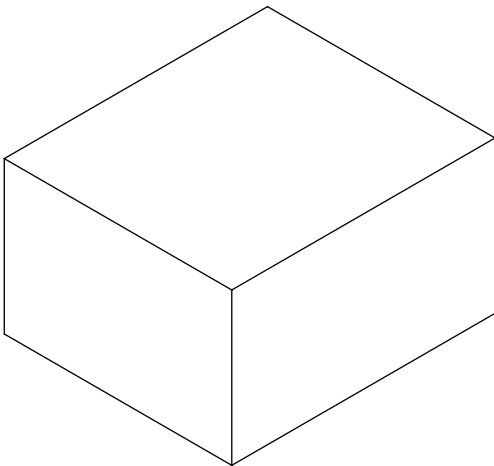

BOX WITH UPHOLSTERY

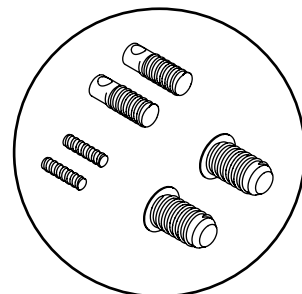
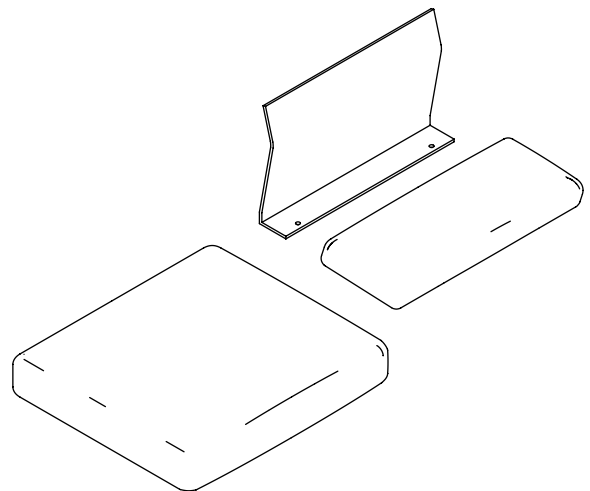
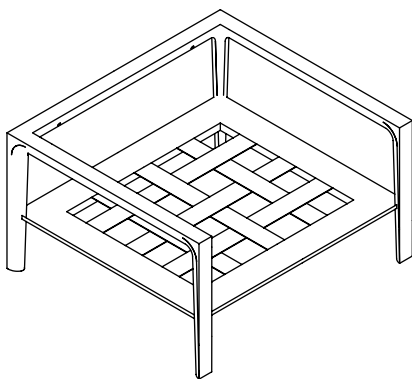
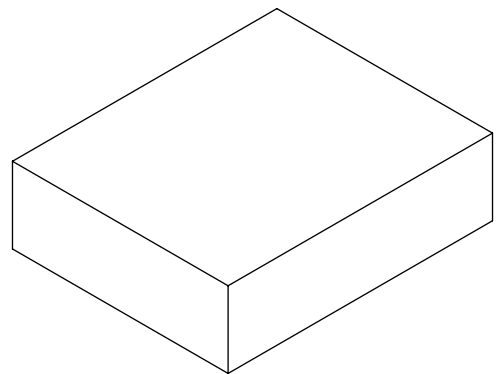

WOODEN STRUCTURE

SEAT AND BACKREST CUSHION,
UPHOLSTERED BACK PANEL,
HARDWARE

LING

ASSEMBLY

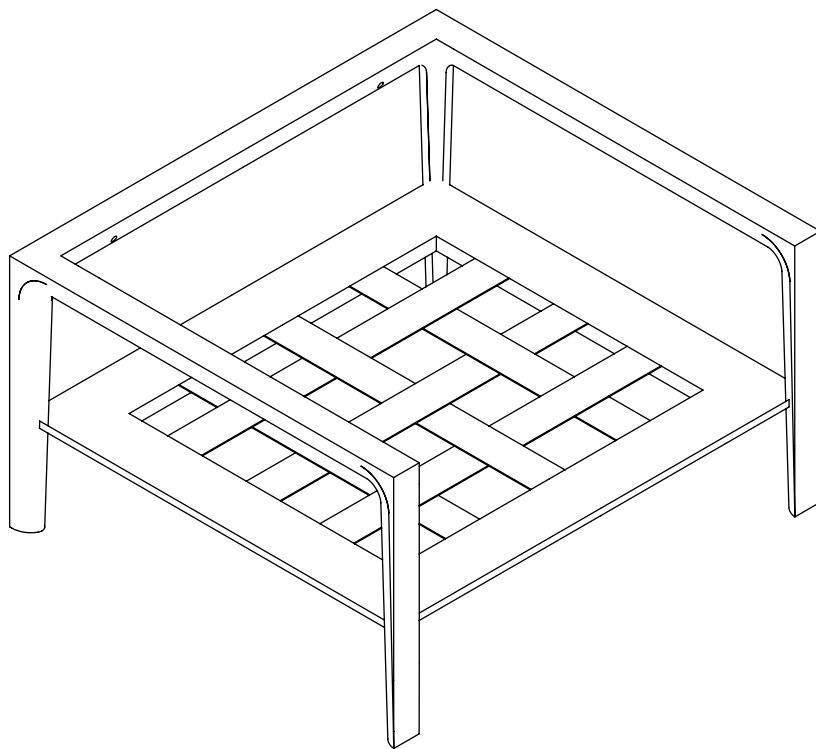

REMOVE THE WOODEN STRUCTURE FROM THE PACKAGING AND PLACE IT WITH ITS LEGS
ONTO THE FLOOR.

LING

ASSEMBLY

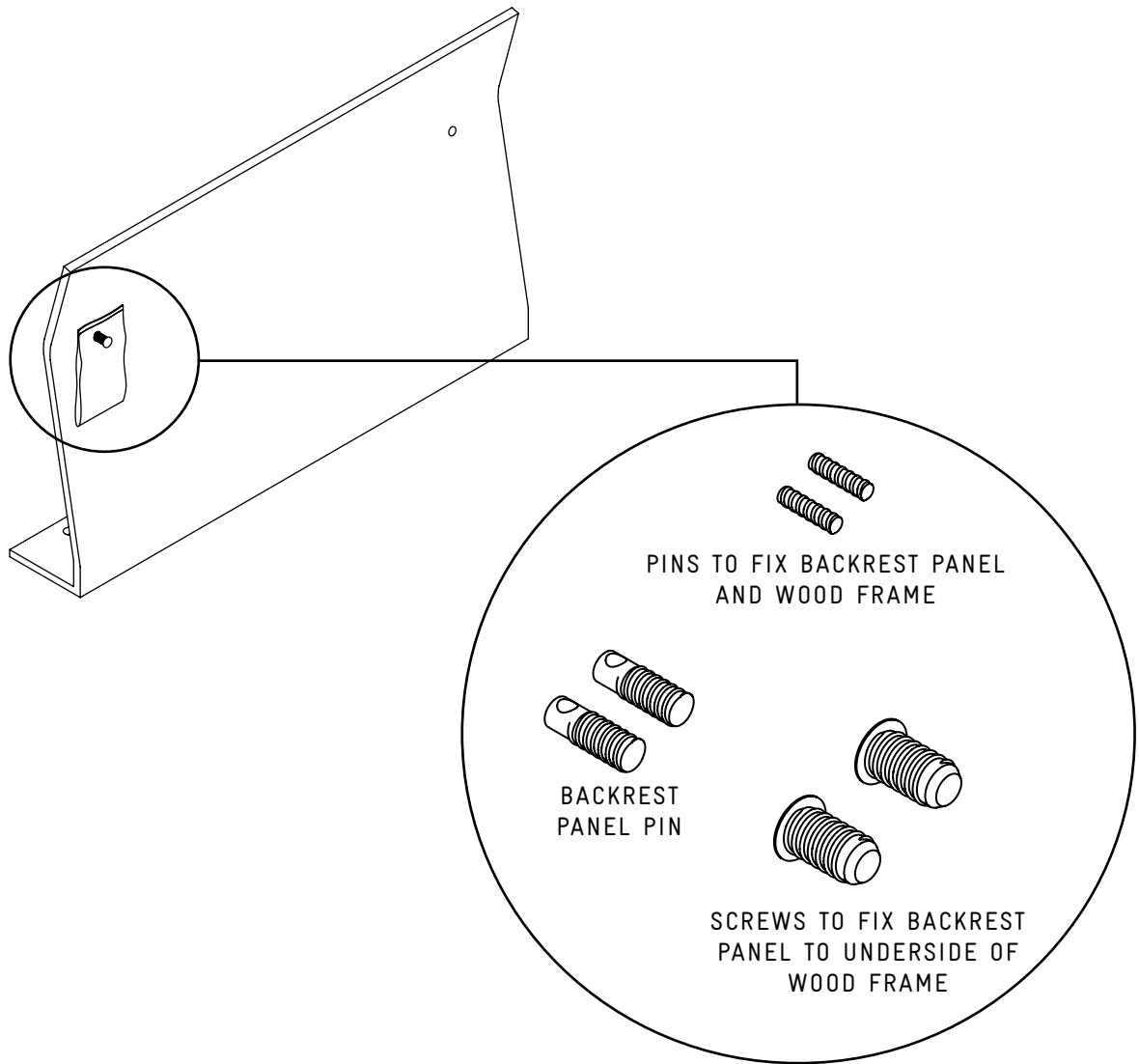

REMOVE THE UPHOLSTERY AND THE HARDWARE FROM ITS PACKAGING AND PLACE IT ON A CLEAN SURFACE.

TAKE THE UPHOLSTERED BACKREST PANEL AND DETACH THE HARDWARE BAG; THE SCREW USED TO FIX THE HARDWARE BAG TO THE PANEL IS NOT REQUIRED FOR ASSEMBLY.

LING

ASSEMBLY

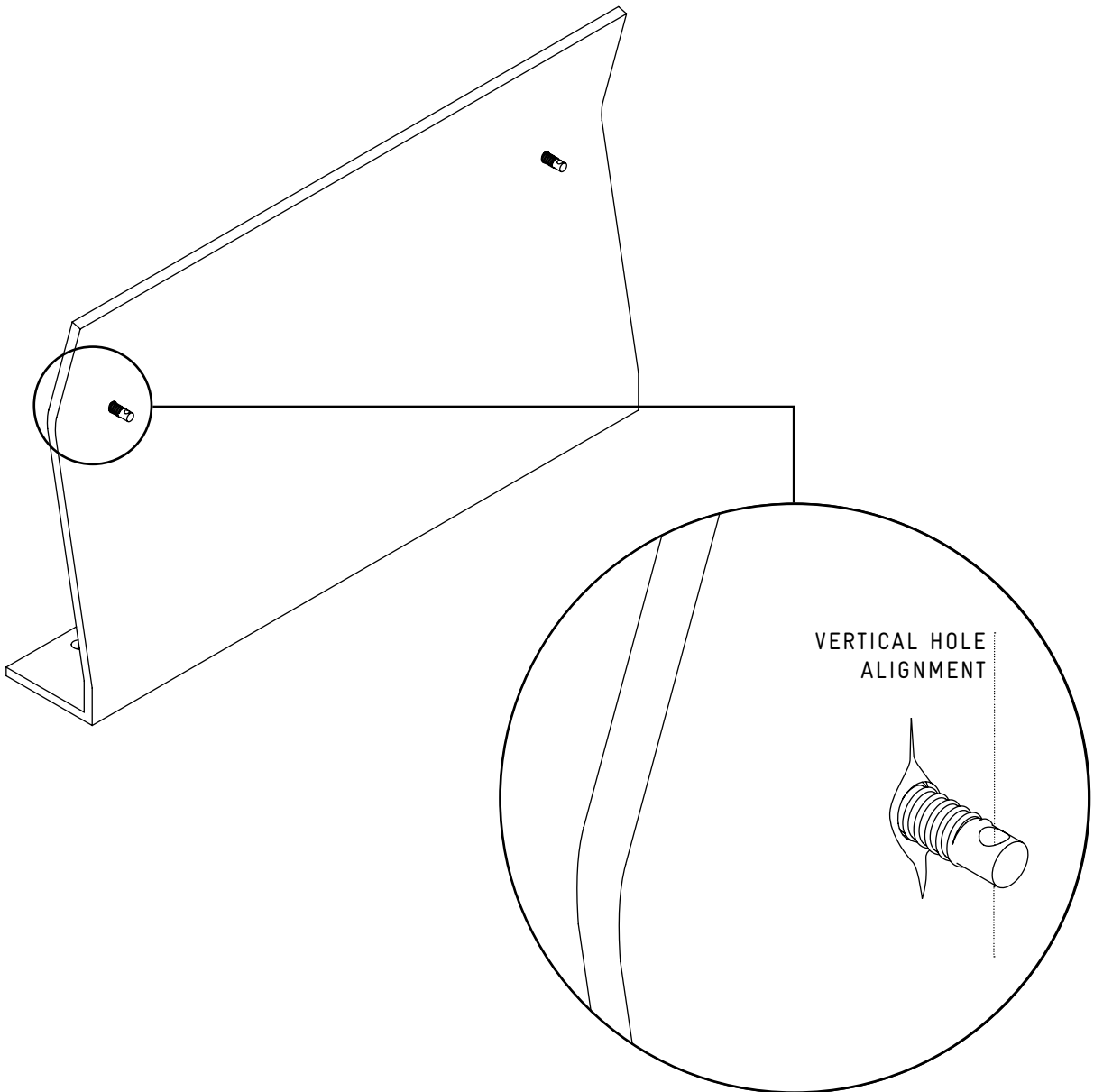

SCREW THE PIN ONTO THE PANEL ENLARGING THE FABRIC HOLES;
THE HOLE IN THE PIN MUST BE POSITIONED VERTICALLY, OTHERWISE YOU WON`T BE ABLE TO INSERT
THE SECURITY PIN AFTERWARDS.

LING

ASSEMBLY

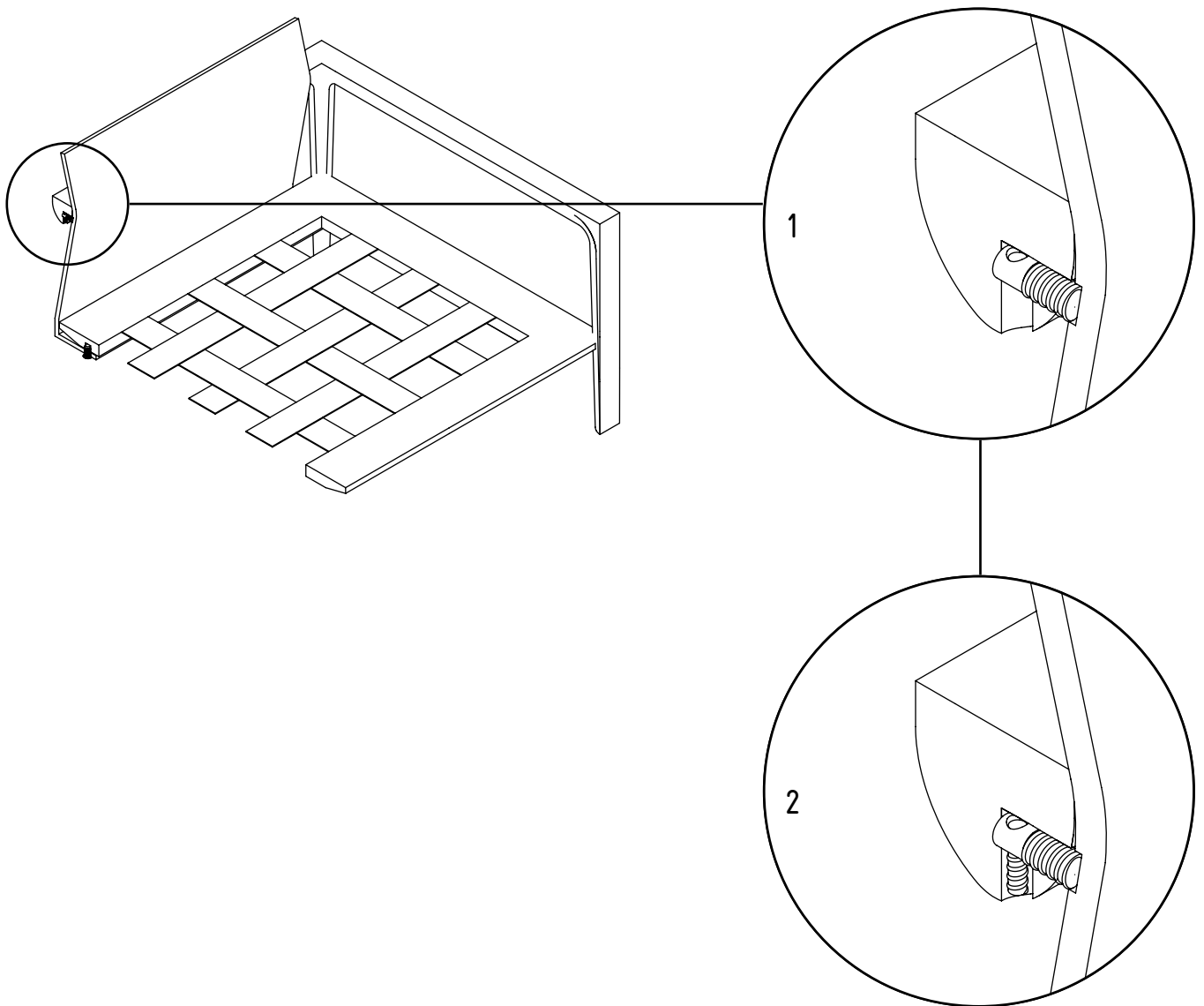

PLACE THE PANEL ON THE BACK INSERTING THE PINS INTO THE WOODEN STRUCTURE (1).
MOUNT THE SECURITY PIN WITHOUT TIGHTENING (2).

LING

ASSEMBLY

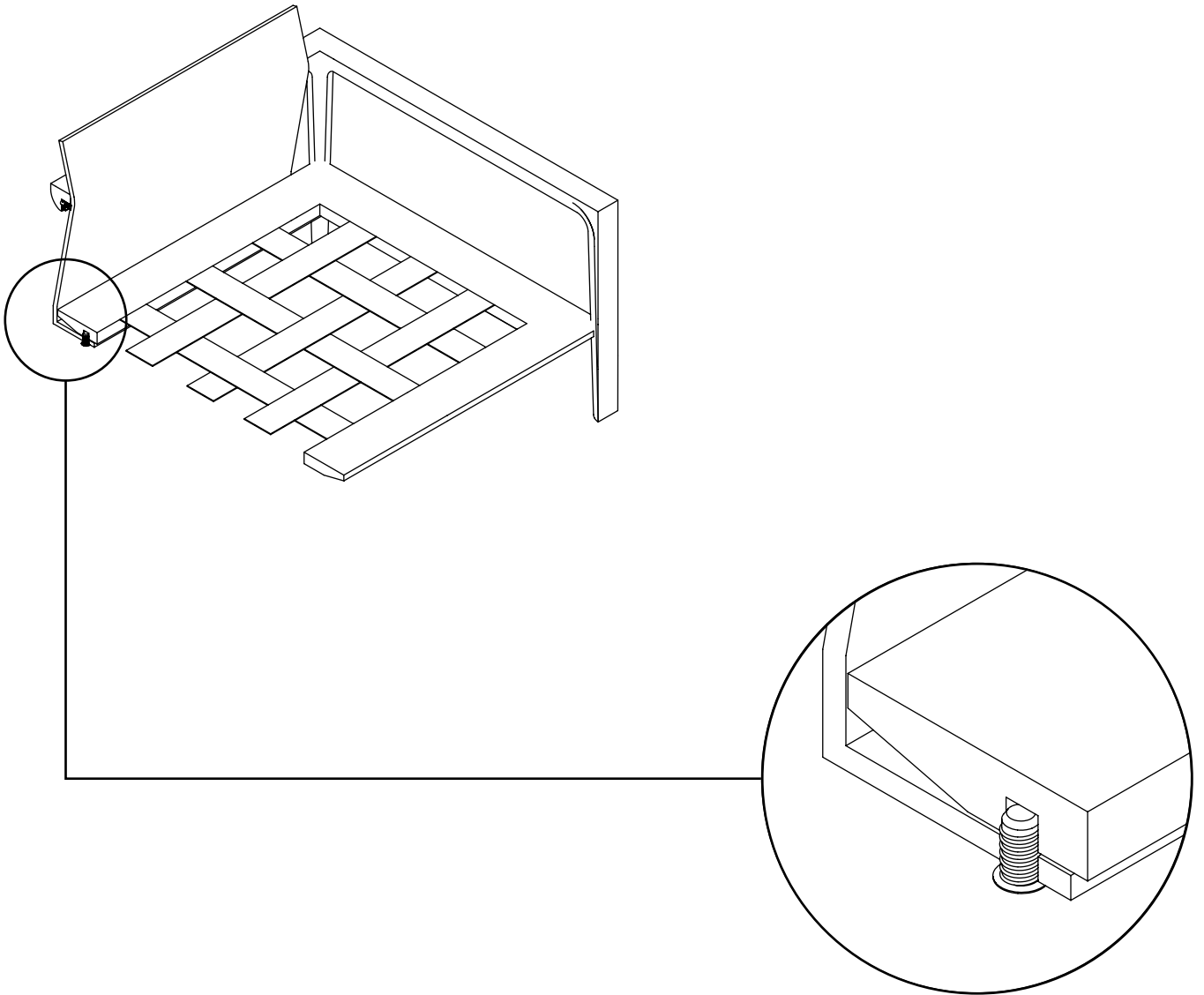

MOUNT THE LOWER PART OF THE PANEL TO THE UNDERSIDE OF THE WOODEN FRAME USING THE HARDWARE PROVIDED.
FINALLY, GRADUALLY TIGHTEN ALL THE SCREWS WITHOUT USING FORCE.

LING

ASSEMBLY

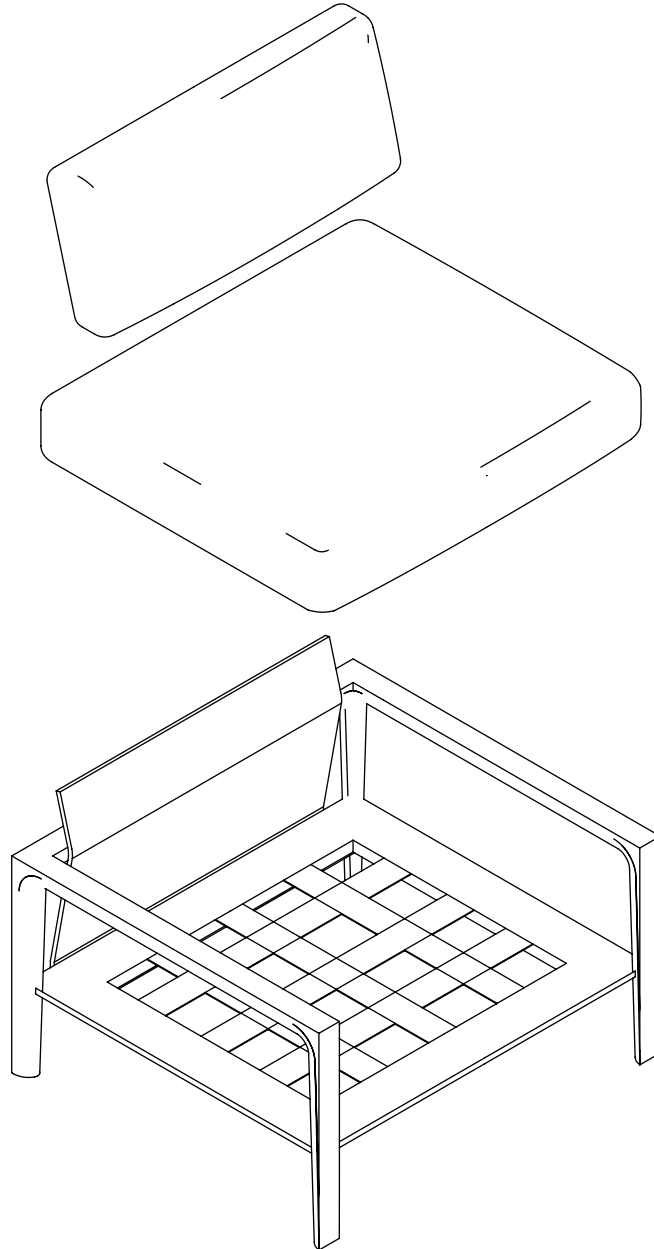

PLACE THE SEAT CUSHION WITH THE ZIPPER FACING THE BACKPANEL ONTO THE FRAME,
THE HIGHER CUSHION EDGE IS ON THE FRONT.
FINALLY PLACE THE BACKREST CUSHION WITH THE ZIPPER FACING DOWN.

LING

