



# SERVICE PARTS LIST

**BULLETIN NO.**  
**54-26-2620**

SPECIFY CATALOG NO. AND SERIAL NO. WHEN ORDERING PARTS		REVISED BULLETIN	DATE
<b>18 Volt 1/4" Hex Impact Driver</b>			Jan. 2011
CATALOG NO.	<b>2650-20</b>	STARTING SERIAL NO.	<b>B55A</b>
		WIRING INSTRUCTION <b>SEE PAGE 3</b>	

**EXAMPLE:**  
00 0 Component Parts (Small #)  
Are Included When Ordering  
The Assembly (Large #).

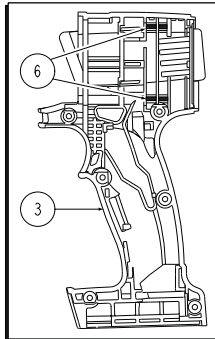

Place Rubber Slugs (6) as shown, four in each handle half (2,3).

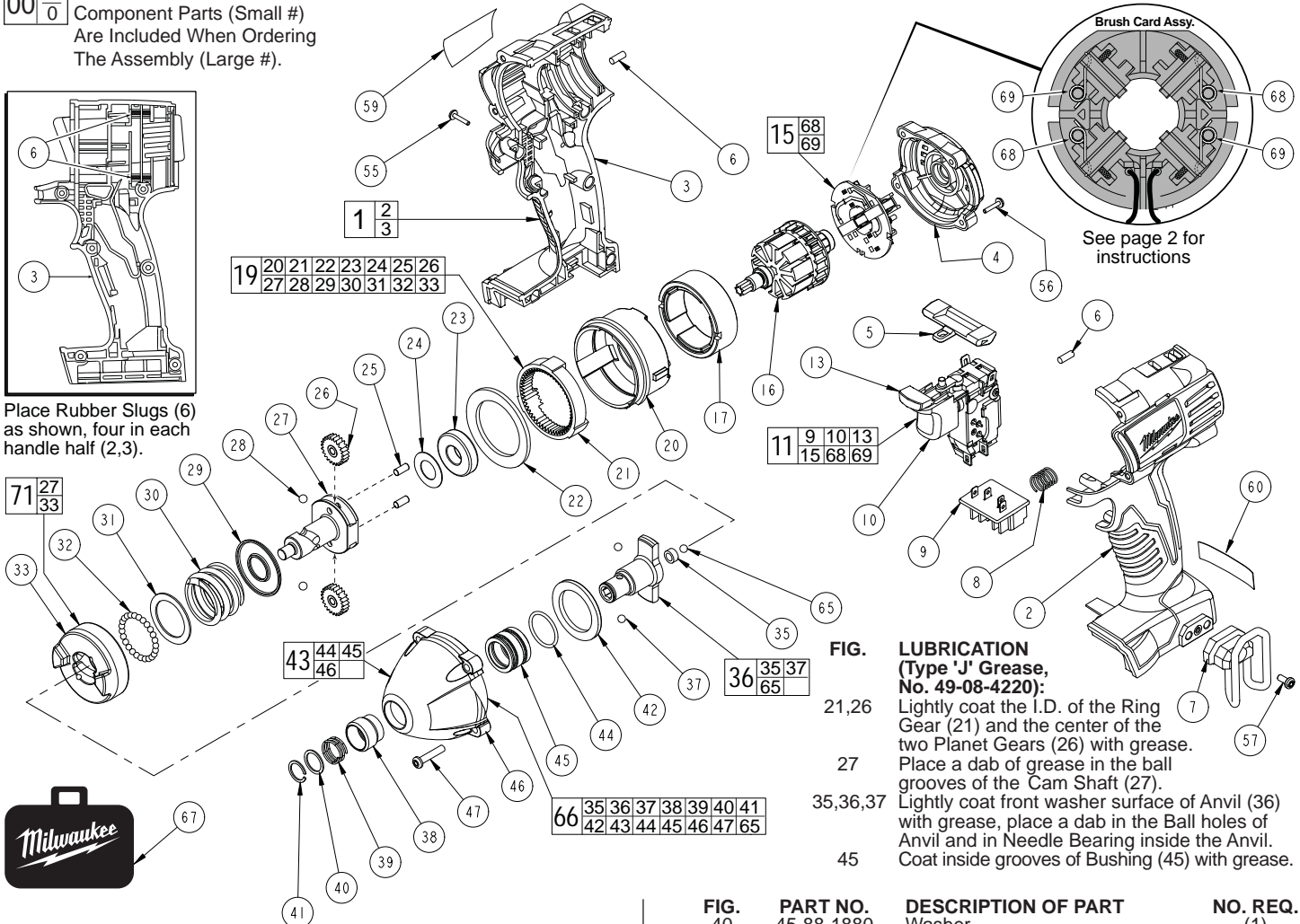

**FIG. LUBRICATION (Type 'J' Grease, No. 49-08-4220):**

- 21,26 Lightly coat the I.D. of the Ring Gear (21) and the center of the two Planet Gears (26) with grease.
- 27 Place a dab of grease in the ball grooves of the Cam Shaft (27).
- 35,36,37 Lightly coat front washer surface of Anvil (36) with grease, place a dab in the Ball holes of Anvil and in Needle Bearing inside the Anvil.
- 45 Coat inside grooves of Bushing (45) with grease.

FIG.	PART NO.	DESCRIPTION OF PART	NO. REQ.
1	31-44-2430	Handle Assembly	(1)
2	-----	Left Handle Half	(1)
3	-----	Right Handle Half	(1)
4	42-52-0062	End Cap	(1)
5	45-24-0300	Forward / Reverse Shuttle	(1)
6	45-30-0250	Rubber Slug	(8)
7	42-70-5150	Belt Hook	(1)
8	40-50-1090	Spring	(1)
9	-----	Contact Block	(1)
10	23-66-0425	Switch	(1)
11	23-66-0426	Switch/Brush Card Assembly	(1)
13	-----	LED Assembly	(1)
15	22-22-1630	Brush Card Assembly	(1)
16	16-01-3010	Service Armature Assembly	(1)
17	18-01-3010	Service Field	(1)
19	14-30-0920	Gear Box Assembly	(1)
20	-----	Rear Case	(1)
21	-----	Ring Gear	(1)
22	-----	Retaining Ring	(1)
23	-----	Ball Bearing	(1)
24	-----	Washer	(1)
25	-----	Pin	(2)
26	-----	Planet Gear	(2)
27	-----	Cam Shaft	(1)
28	-----	3/16" Steel Ball	(2)
29	-----	Washer	(1)
30	-----	Compression Spring	(1)
31	-----	Washer	(1)
32	-----	3.0mm Steel Ball	(30)
33	-----	Hammer	(1)
35	-----	Needle Bearing	(1)
36	42-06-0560	1/4" Hex Drive Anvil Assembly	(1)
37	02-02-0170	3.5mm Steel Ball	(2)
38	45-22-0825	Sleeve	(1)
39	40-50-1470	Spring	(1)

FIG.	PART NO.	DESCRIPTION OF PART	NO. REQ.
40	45-88-1880	Washer	(1)
41	34-60-0725	Retaining Ring	(1)
42	45-88-2025	Front Washer	(1)
43	28-50-0900	Front Case Sub-Assembly	(1)
44	-----	Retaining Ring	(1)
45	-----	Bushing	(1)
46	-----	Front Case	(1)
47	06-82-7010	8-18 x 24 Pan Hd. Screw	(4)
55	06-82-6350	M3 Pan Hd. T-10 Screw	(7)
56	06-82-7336	M3 Pan Hd. T-10 Screw	(4)
57	06-82-5275	6-32 x 5/16" Slit. Pan Hd. T-15 Screw	(1)
59	12-20-2650	Service Nameplate Kit	(1)
60	10-20-2695	Warning Label	(1)
65	02-02-1300	5mm Steel Ball	(1)
66	14-30-0950	Front Case Assembly	(1)
67	42-55-2650	Carrying Case	(1)
68	40-50-2170	Brush Spring - Right Handed	(2)
69	40-50-2175	Brush Spring - Left Handed	(2)
71	14-46-1710	Cam Shaft/Hammer Kit	(1)

**FIG. NOTES:**

- 15,16,17 See service note and illustration on the back of bulletin to aid with the removal and installation of the the Brush Card (15), Armature (16) and Field (17).
- 17 Field (17) to be positioned with side cut-outs to the front.
- 20,21 Position Ring Gear (21) with three lugs face down to interlock in the bottom of Rear Case (20).
- 20,46 Be sure to match the raised contours on the bottom of Rear Case (20) with raised contour on the bottom of the Front Case (46) when assembling.
- 29,30 Make sure concave side of Washer (29) faces Spring (30).
- 42,46 Tapered end of Front Washer (42) to face Front Case (46).

# INSTALLING BRUSH SPRINGS ON A BRUSH CARD ASSEMBLY WITH FOUR (4) BRUSHES

There are two 40-50-2170 RH Brush Springs and two 40-50-2175 LH Brush Springs. Follow the instructions below for proper installation.

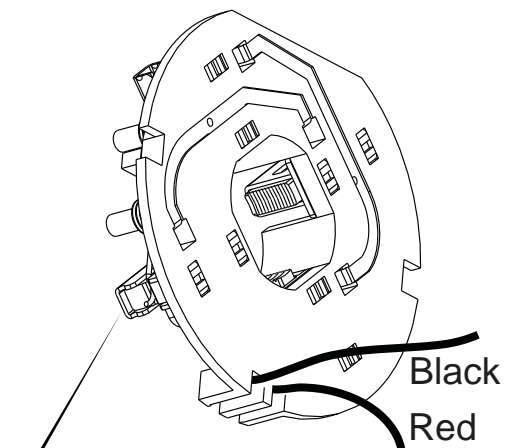

Black  
Red

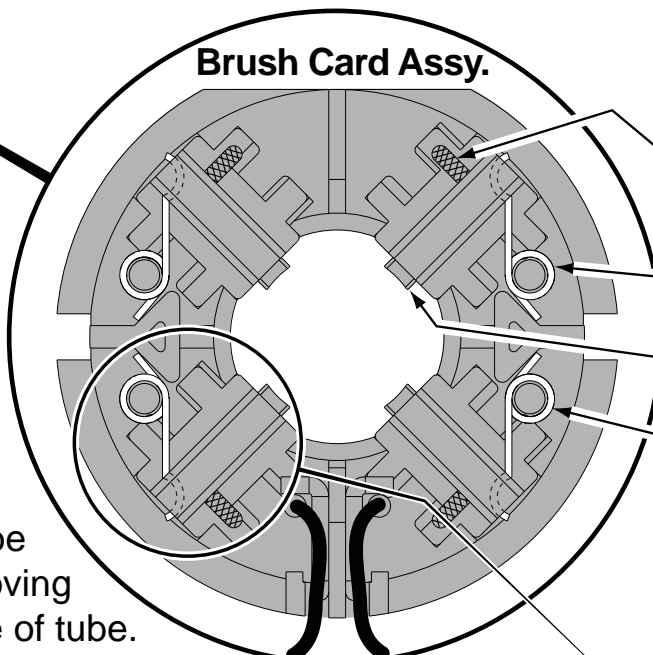

**Brush Card Assy.**

- Brush Shunt (4 places)
- Right Brush Spring (2x)
- Carbon Brush (4x)
- Left Brush Spring (2x)

Be sure carbon brush is in brush tube with brush shunt moving freely in side groove of tube.

Place brush spring over post with short leg positioned downward as shown. Be sure spring is completely down with short leg trapped against 'Y' shaped wall on brush card.

While holding spring in place, bring the long leg of spring over the brush tube and through rear opening of tube. Position rounded hook of spring in groove on back of carbon brush. Be sure to check for free movement between carbon brush, brush shunt and brush spring.

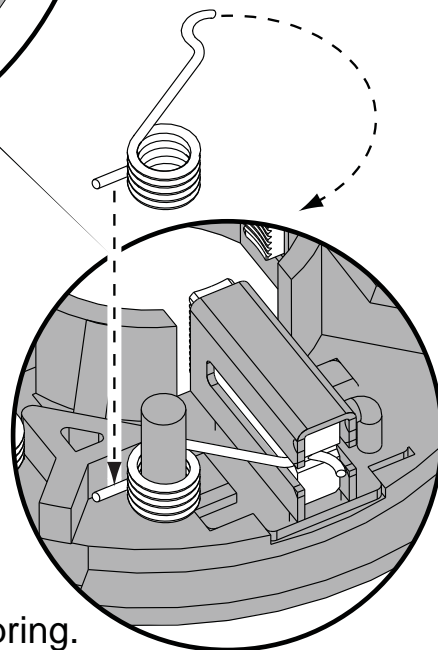

Wrong



Correct

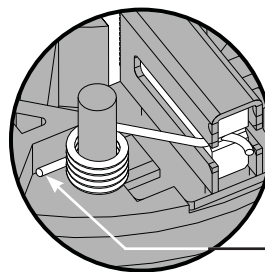

Short leg of spring to the bottom

**NOTE:** Before attempting to remove armature or brush card assembly- Pull brush back until the brush spring slides from the back of the brush, onto the side of the brush as shown. (Do this to all four brushes). This will hold brushes out of the way for ease of servicing and will help prevent damage to the carbon brushes and the commutator of the armature.

To reinstall components, orient the Field with the cut-outs facing forward, place the Armature into the Field prior to assembling onto the Brush Card Assembly. Make sure that all brushes are returned to the proper position once Brush Card, Armature and Field are properly seated in the Left Handle Half.

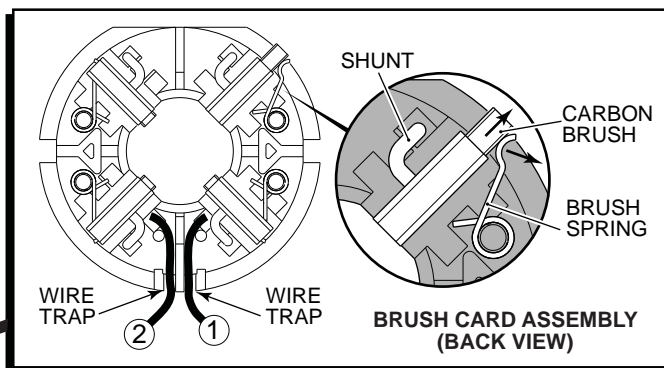

Be sure to place black wire #1 and red wire #2 firmly in the wire traps on the bottom of brush card to prevent pinching between handle halves and end cap.

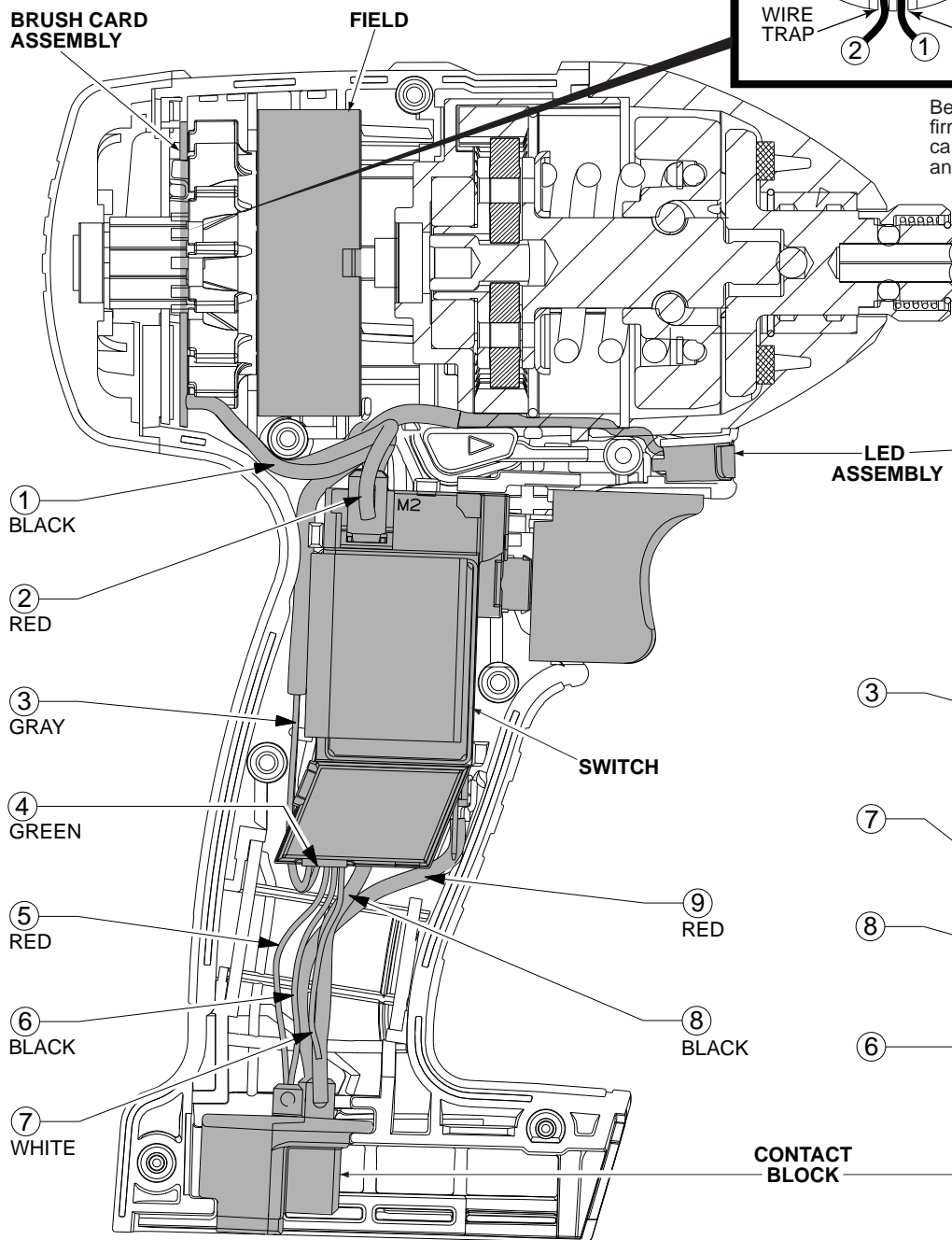

Model 2650-20 shown

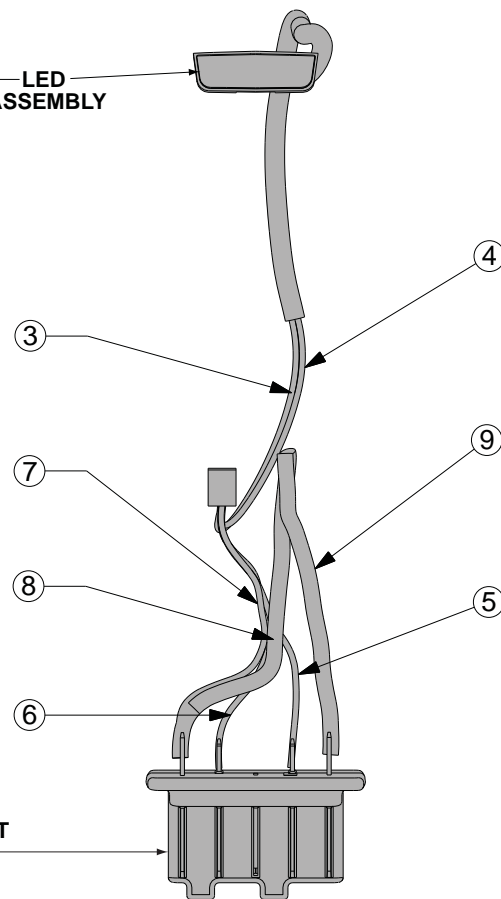

### WIRING SPECIFICATIONS

Wire No.	Wire Color	Origin or Gauge	Length	Terminals, Connectors and 1 or 2 End Wire Preparation
1	Black	-----	-----	Component of the Switch/Brush Card Assembly.
2	Red	-----	-----	Component of the Switch/Brush Card Assembly.
3	Gray	-----	-----	Component of the Switch/Brush Card Assembly.
4	Green	-----	-----	Component of the Switch/Brush Card Assembly.
5	Red	-----	-----	Component of the Switch/Brush Card Assembly.
6	Black	-----	-----	Component of the Switch/Brush Card Assembly.
7	White	-----	-----	Component of the Switch/Brush Card Assembly.
8	Black	-----	-----	Component of the Switch/Brush Card Assembly.
9	Red	-----	-----	Component of the Switch/Brush Card Assembly.

AS AN AID TO REASSEMBLY, TAKE NOTICE OF WIRE ROUTING AND POSITION IN WIRE GUIDES AND TRAPS WHILE DISMANTLING TOOL.

BE CAREFUL AND AVOID PINCHING WIRES BETWEEN HANDLE HALVES WHEN ASSEMBLING.