

ART 902T

PN82 Stainless Steel 2 Piece Ball Valve

Features

- Screwed BSP Taper
- RPTFE (15%) Seats
- PTFE Seals
- Full Bore
- PN82 Rated
- Locking Device

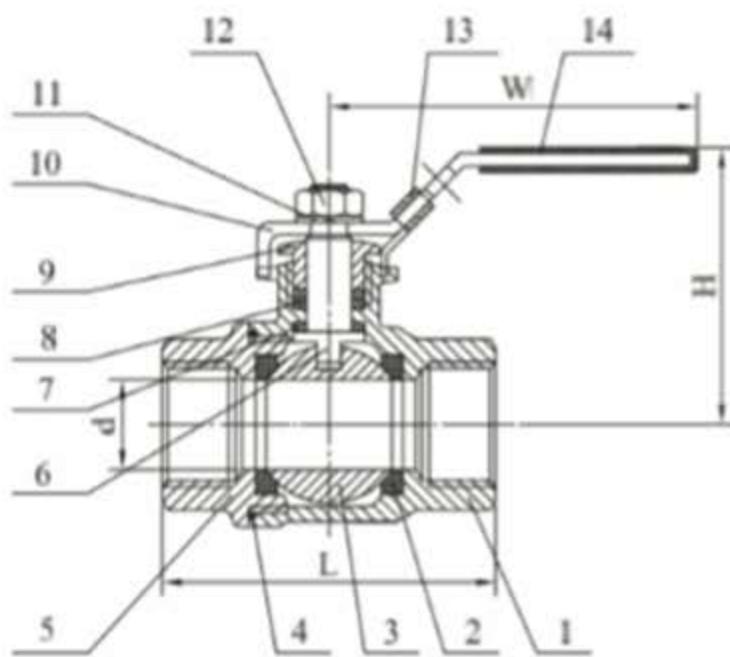

Pressure / Temperature

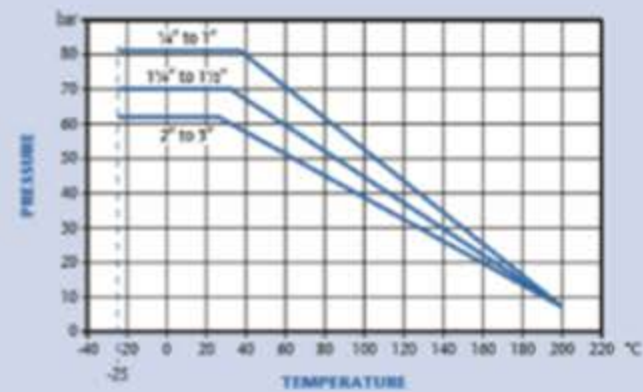

DN	1/4"	3/8"	1/2"	3/4"	1"	1 1/4"	1 1/2"	2"	2 1/2"	3"
d	11.5	12.5	15	20	25	32	40	50	65	76
L	49	49	57	64	77	90	105	125	153	172
H	54	54	56	65	70	75	93	99	123	140
W	105	105	105	118	150	150	182	182	254	254
Torque	4	4	5	8	10	14	18	25	48	75
Kgs	0.23	0.23	0.24	0.45	0.65	1.05	1.70	2.61	5.01	7.61

Technical Data

Max Pressure 82 Bar (1/4"-1") 69 Bar (1 1/4"-1 1/2") 62 Bar (2"-3")
Working Temperature -25°C to +200°C

N.	Part Name	Material
1	Body	CF8M
2	Ball Seat	R-PTFE (15%)
3	Ball	Stainless Steel 316
4	Body Gasket	PTFE
5	Cap	CF8M
6	Stem	Stainless Steel 316
7	Thrust Washer	PTFE
8	Stem Packing	PTFE
9	Gland Nut	Stainless Steel 304
10	Handle	Stainless Steel 304
11	Spring Washer	Stainless Steel 304
12	Nut	Stainless Steel 304
13	Lock Device	Stainless Steel 304
14	Handle Cover	Plastic