

ART 105

PN16 Cast Iron Gate Valves

Features

- Flange Mounting PN16 Only
- BS EN 558-1 Series 14
- DIN 3352F4

Pressure/Temperature

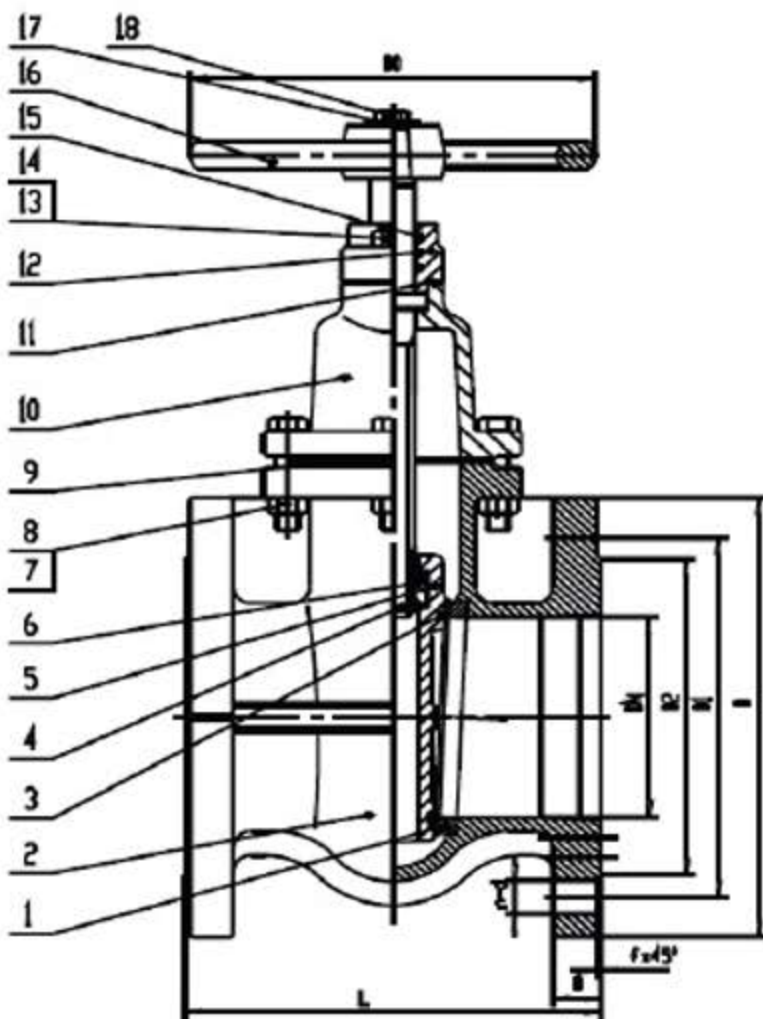
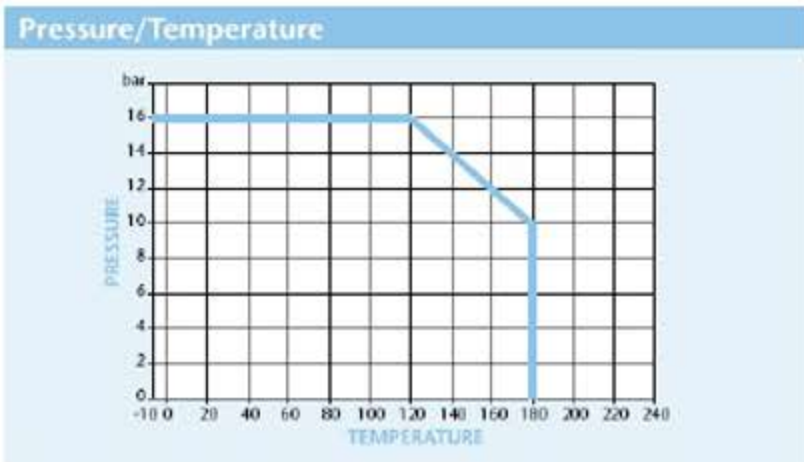

Technical Data

Pressure 16 Bar
Working Temperature -10°C to +180°C

DN	50	65	80	100	125	150	200	250	300
L	150	170	180	190	200	210	230	250	270
D	165	185	200	220	250	285	340	405	460
D1	125	145	160	180	210	240	295	355	410
D2	102	124	140	158	188	212	268	320	378
B	16	16	17	17	18	20	21	23	24
f	2	2	2	2	3	3	3	3	4
n-d	4-19	4-19	8-19	8-19	8-19	8-23	12-23	12-28	12-28
D0	130	130	150	185	185	195	225	245	285
Kgs	10.8	12.8	16.6	22.8	32.1	42.9	71.3	98	145

N.	Part Name	Materials
1	Body Seat Ring	Cast Brass
2	Body	Ductile Iron
3	Wedge Seat Ring	Cast Brass
4	Stem	Stainless Steel
5	Wedge	Ductile Iron
6	Stem Nut	Cast Brass
7	Bolt	Steel
8	Nut	Steel
9	Flange Gasket	Graphite
10	Bonnet	Ductile Iron
11	Stuffing Box Gasket	Graphite
12	Stuffing Box	Ductile Iron
13	Bolt	Steel
14	Nut	Steel
15	O-ring	NBR
16	Handwheel	Cast Iron
17	Washer	Steel
18	Bolt	Steel