

ART 903 Stainless Steel 3 Piece Ball Valve - PN82

Socket Weld



BSP



Features

- BSP/Socket Weld Ends
- RPTFE (15%) Seats
- PTFE Seals
- PN82 Rated

Pressure / Temperature

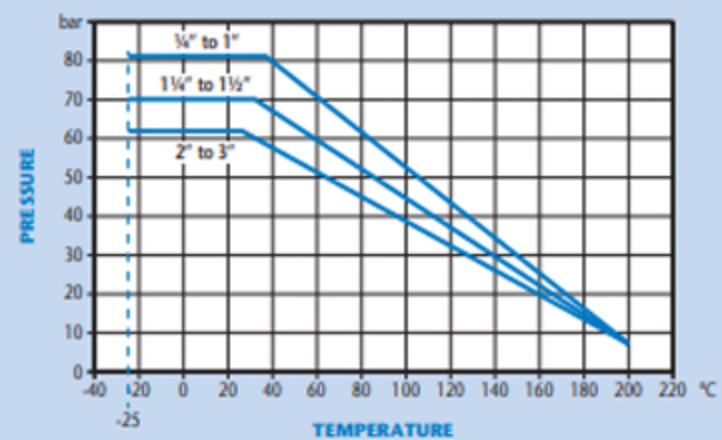

DN	1/4"	3/8"	1/2"	3/4"	1"	1 1/4"	1 1/2"	2"	2 1/2"	3"
d	11	12.5	15	20	25	32	40	50	65	80
L	50	60	75	80	90	110	120	140	185	205
H	51	51	53	60	75	80	88	95	121	135
W	105	105	118	118	150	150	182	182	254	254
Torque	4	4	5	8	10	14	18	25	48	75
Kgs	0.40	0.42	0.45	0.73	1.04	1.65	2.43	3.52	7.14	11.85

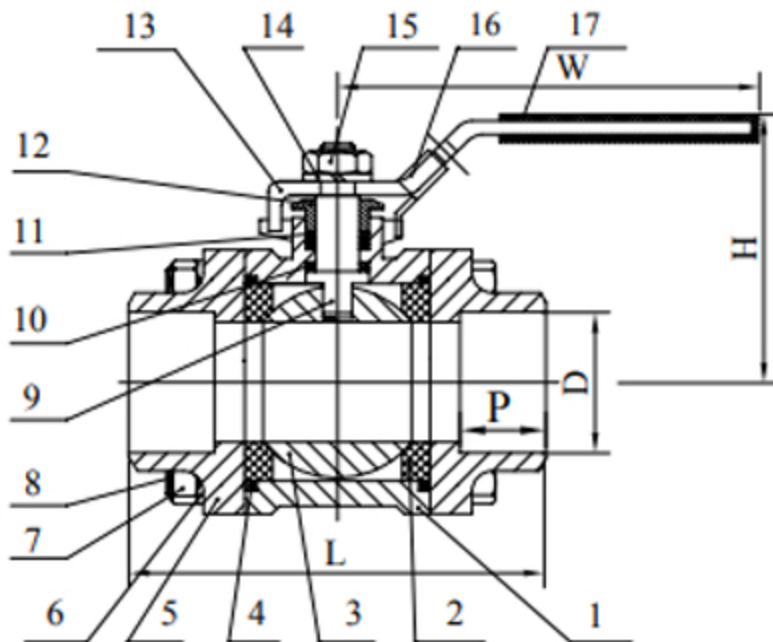

Technical Data

Max Pressure 82 Bar (1/4"-1") 69 Bar (1 1/4"-1 1/2") 62 Bar (2"-3")
Working Temperature -25°C to +200°C

N.	Part Name	Material
1	Body	CF8M
2	Ball Seat	R-PTFE (15%)
3	Ball	Stainless Steel 316
4	Body Gasket	PTFE
5	Cap	CF8M
6	Spring Washer	Stainless Steel 304
7	Nut	Stainless Steel 304
8	Bolt	Stainless Steel 304
9	Stem	Stainless Steel 316
10	Thrust Washer	PTFE
11	Stem Packing	PTFE
12	Gland Nut	Stainless Steel 304
13	Handle	Stainless Steel 304
14	Spring Washer	Stainless Steel 304
15	Nut	Stainless Steel 304
16	Lock Device	Stainless Steel 304
17	Handle Cover	Plastic