



# ART 236

## Ductile Iron PN16 Flanged Double Check Valve

### Features

- Flange Mounting PN16 only (EN 1092-2)
- Epoxy coat finish
- Operates in any position
- WRAS Approved as a non-return valve

### Pressure / Temperature

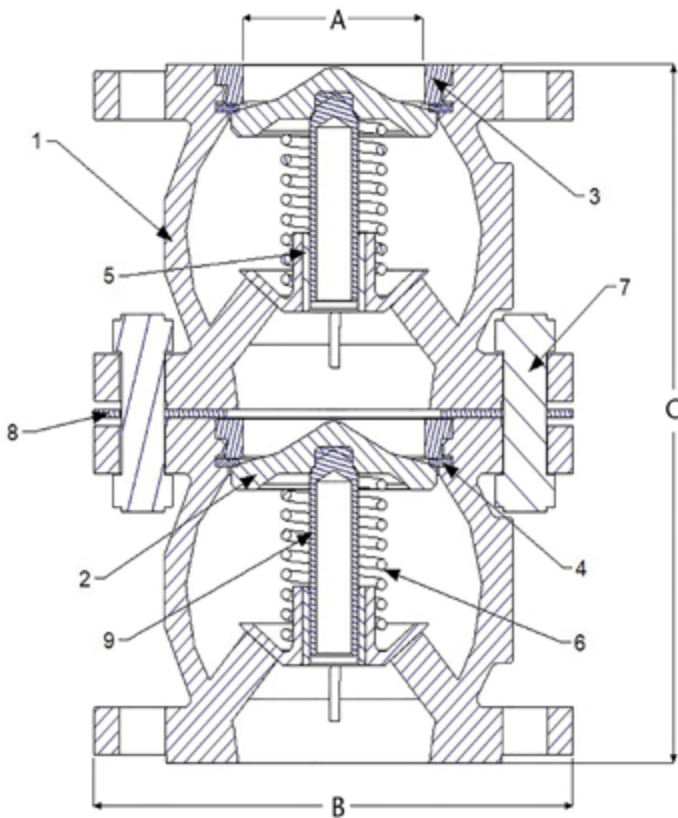
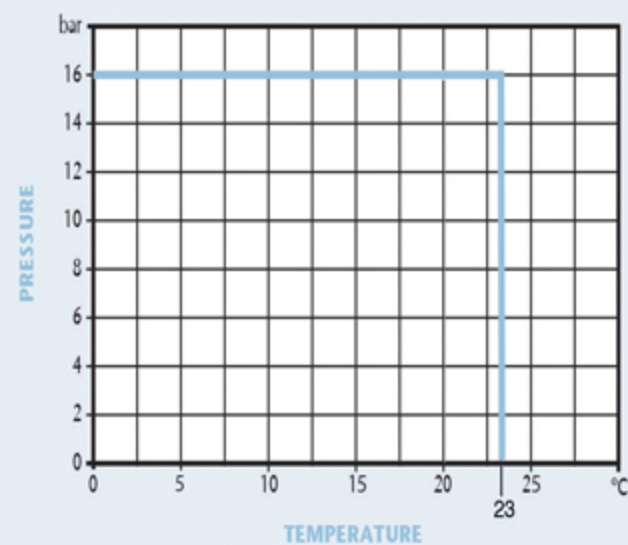

### Technical Data

Maximum Pressure	16 Bar
Working Temperature	0°C to +23°C

DN	50	65	80	100	125	150	200	250
A	50	65	80	100	125	150	200	250
B	165	185	200	220	250	285	340	405
C	205	245	265	315	405	465	565	693
Kgs	12	16.2	17.2	25	40	60	100	188

N	Part Name	Material
1	Body	Ductile Iron SG 420/12
2	Plunger Top	Delrin 150
3	Sealing Ring	Delrin 150
4	Seal	Nitrile 70 Shore
5	Guide Bush	Cz132 DZR Brass
6	Spring	Stainless Steel Grade 304 S26
7	Studs	Mild Steel (Plated)
8	Gasket	Nitrile 70 Shore
9	Plunger Shaft	Cz132 DZR Brass