



ZED BRAKES INSTALLATION & OPERATING INSTRUCTIONS

ZED

Important Warnings

- The release setting requires a specialized understanding of multiple factors. Adjustments to release settings should only be made by an authorized dealer. Any improper adjustment of release setting by any unauthorized person will put the skier at risk of injury and void the warranty.
- Any custom modifications to the binding will invalidate the warranty, and could put the skier at risk of injury.
- Prior to each use the binding should be checked for any broken parts, correct release function, and contamination. If anything is defective or broken please return the binding to an authorized dealer for service.
- Since skiing has inherent risks, do not overestimate your ability when describing your skiing level to the authorized dealer who will set your release setting. If in doubt, underestimate your ability, and return to the authorized dealer to have an increase in retention made.
- Skiing the G3 ZED binding without a ski brake or a ski leash can put others at risk, as well as risk the loss of the ski and binding. A ski brake alone is not sufficient to protect against the loss of a ski in deep snow. The use of a ski leash is not recommended in avalanche terrain.
- Ski touring is a demanding sport in which environmental conditions and terrain can change quickly and be hazardous. Obtain proper training and rescue equipment before ski touring, and don't overestimate your abilities. Always make use of all available weather and avalanche condition information prior to touring. Never ski tour under the influence of any drug or mind changing substance.
- Never ski tour alone.
- Due to the exposure to environmental conditions that are common during ski touring (ice, snow, water, dirt) the release setting may change. Extended or incorrect storage can also affect release setting. At the start of each season, the release setting should be checked using specialized equipment at an authorized dealer.
- Specialized alpine touring boots with "TECH" inserts are required for use with G3 ZED bindings. Any non compliant boot or excessively worn "TECH" inserts can alter the release setting. The boot is an integral part of the release system. The release setting should be checked using specialized equipment at an authorized dealer with the intended boot(s) for use.
- During transport, bindings can become contaminated with salt, dirt and other contaminants that can alter or impair the release function. Cover your bindings during transport to reduce this risk.
- Any unintended use of the binding will void the warranty, and could put people at risk.
- Use only genuine G3 accessories for ZED bindings to ensure that the release setting or any other design feature is not compromised.

Boot Compatibility

- The ZED bindings are only compatible with alpine touring ski boots (ISO 9523) with Tech compatible inserts.
- Bellows touring boots or NTN type boots with TECH inserts are not currently supported; the flex creates an unpredictable release environment.
- For the most current information, videos and instructions on mounting and using your ZED bindings go to <http://www.genuineguidegear.com>.
- For full G3 product warranty details please visit: <http://www.genuineguidegear.com/service/g3-product-warranty>.

1. Brake
2. Brake shim - retail version
3. Brake installed on heel assembly (heel assembly sold separately)
4. Brake shim - demo version (included with ZED demo track)

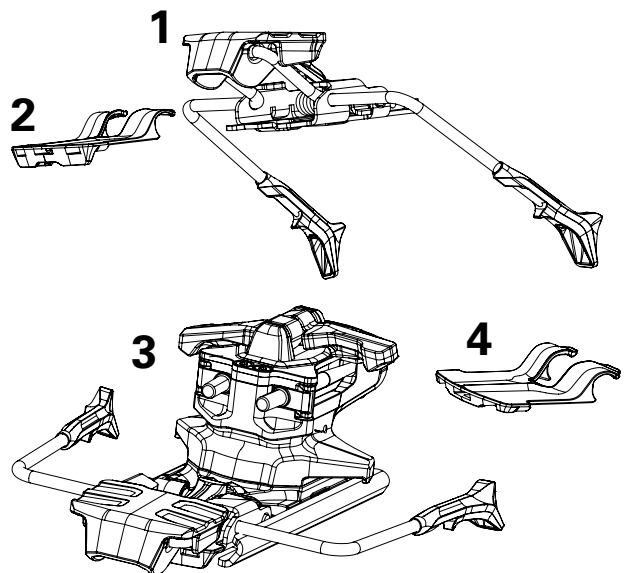

For the most current information, videos and instructions on mounting and using your ZED bindings go to www.genuineguidegear.com.

For full G3 product warranty details please visit: www.genuineguidegear.com

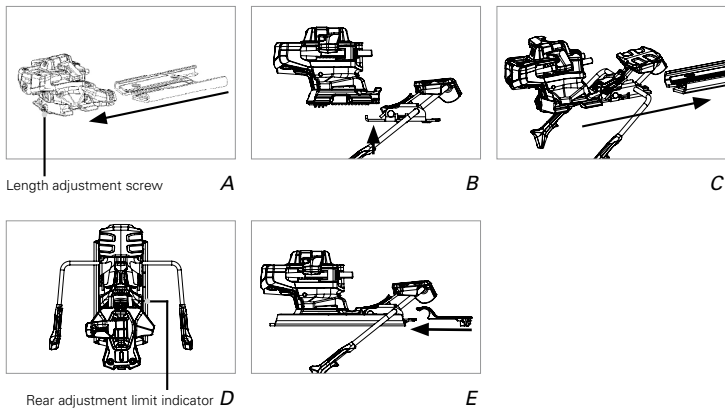

1. INSTALLING THE BRAKE

- Remove the heel turret assembly using the length adjustment screw (A). Use a PozIDriv #3 screwdriver and turn counter-clockwise to remove.
- Connect the brake to the underside of the base of the heel turret (B). The fangs on the rear of the brake should seat into the pockets on the bottom of the turret.
- Install the heel turret assembly and brake by driving it on from the back of the heel track using the length adjustment screw (C) and a PozIDriv #3 screwdriver. Bring the turret forward until the adjustment limit indicator mark on the turret matches the rear adjustment limit indicator on the heel track (D).
- Attach the brake shim to the front of the brake (E) by pressing it on with your finger until it clicks into place. **If you are using the demo track for the ZED binding ensure you use the accompanying demo brake shim packaged with the demo track.** When uninstalling the brake, the shim will automatically be removed when you remove the heel assembly from the heel track.

Note: If you are installing the brake in conjunction with mounting the binding for the first time, you can use steps 1b - 1d above to replace step 4c in the ZED mounting instructions to avoid setting up the heel assembly twice.

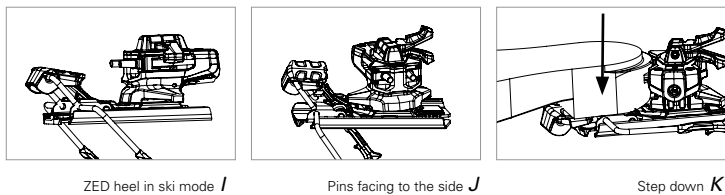

3. SWITCHING FROM SKI MODE TO TOUR MODE

- To change the heel assembly from ski mode (I) into tour mode (J), the heel assembly needs to be rotated so that the heel pins face to the left or to the right (J). It helps to depress the brake a little to avoid catching your fingers as you rotate the heel.

Note: It is very important to ensure that the heel assembly is rotated fully into the touring position (ie. it isn't able to be rotated further). You must feel it click into its correct position to be sure it's locked in tour mode.

- Prior to stepping into the toe of the binding, push down on the toe lever with a ski pole to ensure the toe assembly is in 'step in position' (M). Then click into the toe of the binding with a forward sliding motion from the rear, aimed at the central BootStop. When positioned correctly, the toe pins in the binding jaws will snap tightly into the tech inserts in the toe of your boot.
- Once the boot is in the toe piece, step firmly down onto the brake (K) to lock it into tour mode.
- When in tour mode it is recommended to lock out the toes. Do this by lifting the toe tour mode lever until it is at the tightest setting.

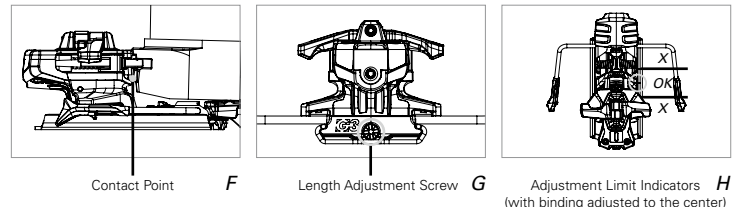

2. SIZE ADJUSTMENT

- Install the ski boot into the binding with the heel positioned in ski mode.

Note: Ensure the next step occurs without weight on the binding. Ideally this step is done on the work bench. In a demo situation have the customer unweight their heel while the ski tech is adjusting the boot sole length.
- Starting with a gap between the binding and the boot, slowly bring the binding just into contact with the boot adjusting the length adjustment screw (G) using a PozIDriv #3 screwdriver. See images above for contact point (F) and location of length adjustment screw (G).
- Front, middle, and rear adjustment limit indicator markings can be found on the heel track. The heel turret assembly should be positioned where the corresponding indicator mark is in between the rear limit indicator and the front limit indicator markings (H).

WARNING!

It is VERY IMPORTANT not to over tighten the gap. As a check, loosen the length adjustment screw very slightly. That adjustment should open the gap. Then, remember to re-adjust the heel of the binding after checking the gap.

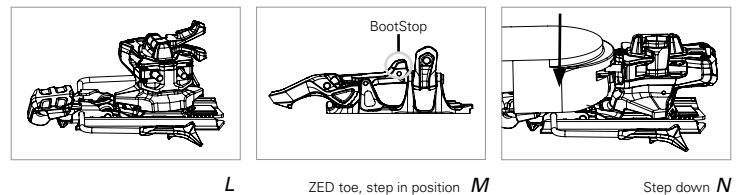

4. SKI MODE

ROTATING THE HEEL FROM TOUR MODE INTO SKI MODE

- When rotating the heel assembly from tour mode into ski mode rotate the heel with your hand. The heel rotation is aided by springs, keep your hand away from the pins as they quickly rotate forward. When correctly in ski mode, the pins will be facing forward and the brake will be deployed.

STEP IN POSITION

- Before stepping into the ZED binding the toe assembly should be placed in the 'step in position'. The toe piece should be oriented with the toe lever pushed down and the jaws open (M). After a release from the binding, it is necessary to switch the binding back to the step-in position before stepping back into the binding.
- Once the toe piece is in the 'step in position', step your boot into the jaws with a forward sliding motion from the rear, aimed at the central BootStop (M). That is a more effective entry angle than trying to enter the binding directly from above.
- Once the toe piece has snapped firmly into the boot toe inserts, step your heel down firmly and the heel pins will engage with the boot heel insert. You are now correctly in ski mode (N).

Note: The G3 ZED binding is only recommended to be skied with the tour mode lever unlocked in 'ski' mode. If the product is skied with the tour mode lock in place you are effectively removing the safety release features of the binding (as well as release functions in avalanche conditions), and putting yourself at risk of injury or death. Skiing the binding this way could void your warranty should you damage the binding in the event of a fall.