

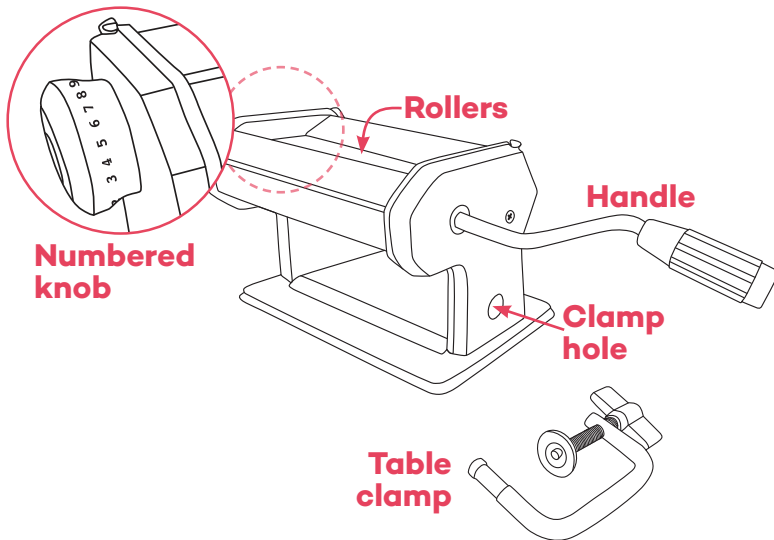

Polymer Clay Press

MMSP4001

Use and care instructions

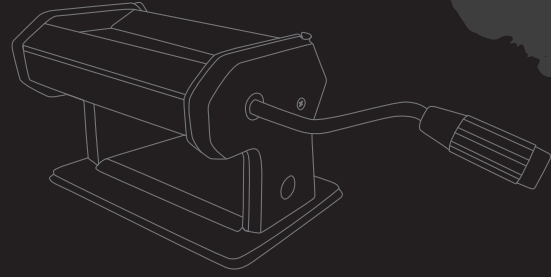

- When feeding clay into the press, make sure it's only a little thicker than the space between the rollers for the best results
- If rolling folded clay, insert the folded end first
- For thorough conditioning of clay, we recommend passing clay through the thickest setting five times, then adjust the settings down one at a time, passing the clay through each adjustment five times
- Turning the handle backwards while rolling clay can cause damage and should be avoided

Instructions for use

Setting up

- Insert handle into the slot of the machine until it locks into place
- If using table clamp, position press at edge of a table/work surface
- Insert top bar of clamp into the hole and secure to surface by twisting turnkey until press can't be moved

Rolling clay

- To keep handle in place, apply pressure towards the machine when winding
- Avoid using thick or stiff clay pieces in the machine as it may cause rollers to misalign
- Before running clay through the rollers, lightly condition using your hands so the clay is pliable
- Either work manually or cut up the clay and recombine it so it's ready for pressing

Changing the settings

- To change setting on press, pull the numbered knob, turn to desired setting, then release
- Start with the widest setting (1) and work upwards until desired thickness is achieved

How to clean

Do not take apart press, follow below steps to clean

- For an in between clean, roll through an old piece of clay to pick up stuck pieces of clay from the rollers
- For a full clean, wipe bottom of rollers under the machine with a dry towel or disposable wipe, or dip a cloth in methylated spirits and run between the rollers until clean
- Don't use tools or sharp objects to remove clay from press as it can result in damage to the mechanisms and settings