

Smart Body Weight Scale

Model: ESB-591

User Manual

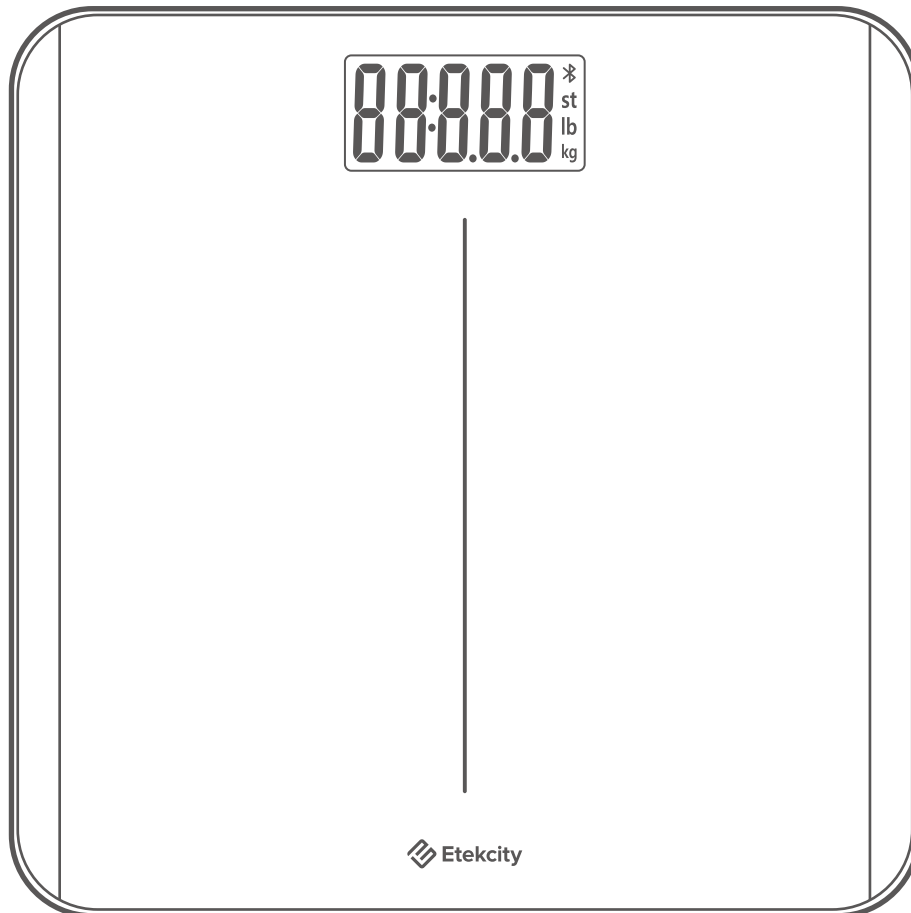

Questions or Concerns?

Mon–Fri, 9:00 am–5:00 pm PST/PDT
support@etekcity.com • (855) 686-3835

Table of Contents

| | |
|-----------------------|-----------|
| Specifications | 3 |
| Package Contents | 3 |
| Safety Information | 4 |
| Function Diagram | 6 |
| Display Diagram | 7 |
| Before First Use | 8 |
| VeSync App Setup | 9 |
| Using the Smart Scale | 12 |
| Maintenance | 14 |
| Common Display Codes | 16 |
| Troubleshooting | 17 |
| Warranty Information | 21 |
| Customer Support | 23 |

Specifications

| | |
|-------------------------|--|
| Weight Capacity | 400 lb / 180 kg / 28 st |
| Increments | 0.1 lb / 0.05 kg |
| Weight Units | lb / kg / st |
| Platform | Tempered Glass |
| Battery | 3 × 1.5V AAA Batteries (Pre-Installed) |
| Auto-Off | 30 seconds |
| Dimensions | 11 × 11 × 0.9 in / 28 × 28 × 2.3 cm |
| Operating System | iOS® 10.0+ or Android™ 5.0+ |

Package Contents

- 1 × Smart Body Weight Scale
- 3 × 1.5V AAA Batteries (Pre-Installed)
- 1 × Quick Start Guide



READ AND SAVE THESE INSTRUCTIONS

Safety Information

Please read and follow all instructions and safety guidelines in this manual.

Medical

- This scale should not be used to diagnose or treat any medical condition.
- Scale data should not be used as a substitute for medical advice from a healthcare professional.

General Use

- Check the scale before using. **Do not** use the scale if it is damaged in any way.
- **Do not** strike or bang on the scale and **do not** use the scale if there is a crack on the glass. While tempered glass is stronger and fractures more safely than ordinary glass, it may shatter unexpectedly after developing a slight crack. If you see a crack, contact **Customer Support** (see page 23).
- The glass platform is slippery when wet. **Always** make sure the platform and your feet are dry before stepping on for measurement.
- Place the scale on a hard, flat surface to avoid tipping.



- To weigh safely and accurately, stand with your feet shoulder-width apart while on the scale. **Do not** stand on the edge of the scale or jump on the scale.
- Avoid standing on the scale for a long period of time, or when not measuring yourself.
- **Do not** overload the scale. Maximum weight capacity is 400 lb / 180 kg / 28 st.
- Keep the scale in a cool area with low humidity.
- Keep the scale away from heat sources, such as ovens or heaters. Avoid temperature fluctuations.
- Store the scale in a horizontal position, not a vertical position.
- This scale is not to be used by persons (including children) with reduced physical, sensory or mental capabilities, or lack of experience and knowledge, unless they have been given supervision or instruction concerning use of the appliance by a person responsible for their safety.
- Handle with care. Not for commercial use. Household use **only**.

SAVE THESE INSTRUCTIONS

Batteries

- **Do not** mix new and old batteries.
- If the scale is not in use for a long period of time, remove the batteries to extend the lifetime of the scale.



Function Diagram

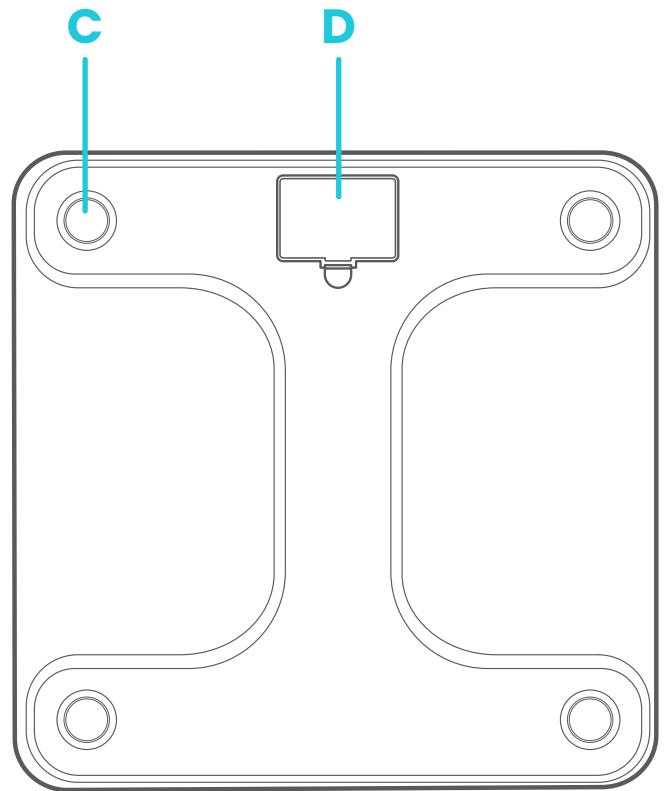
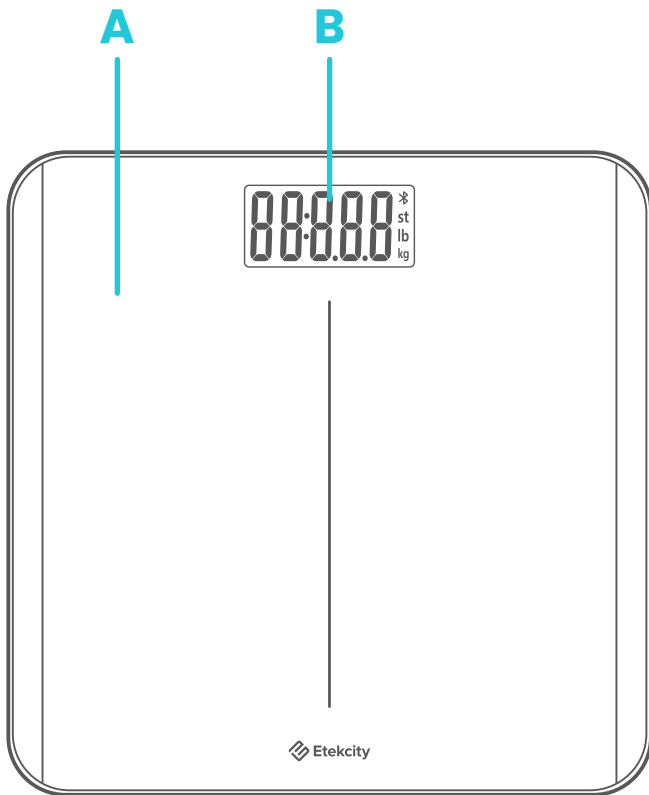

- A.** Weighing Platform
- B.** Display
- C.** Anti-Skid Padding
- D.** Battery Compartment



Display Diagram

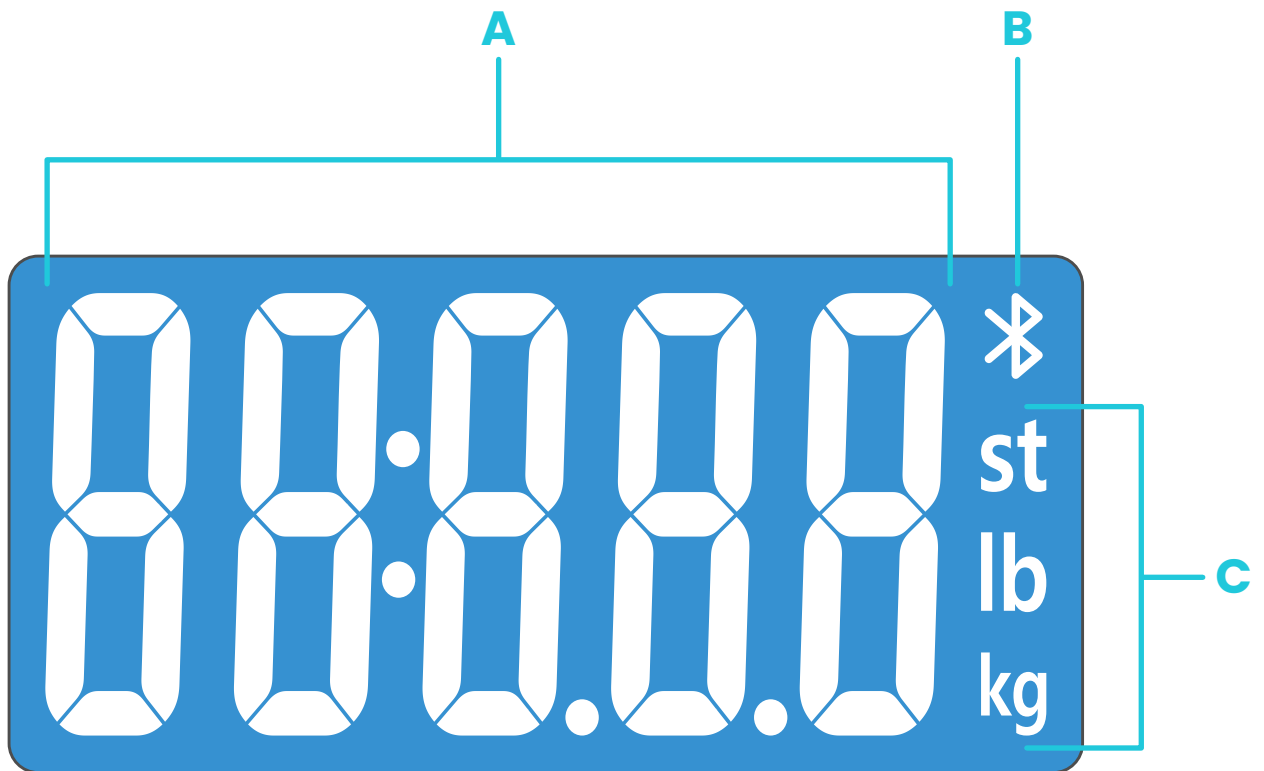

- A. Weight Measurement
- B. Bluetooth® Icon
- C. Weight Units



Before First Use

1. Open the battery compartment on the underside of the scale. Remove the included AAA batteries.
2. Remove the plastic insulator strip from the battery compartment.
3. Replace the batteries. Follow the guidelines in the battery compartment to match the + and – terminals.

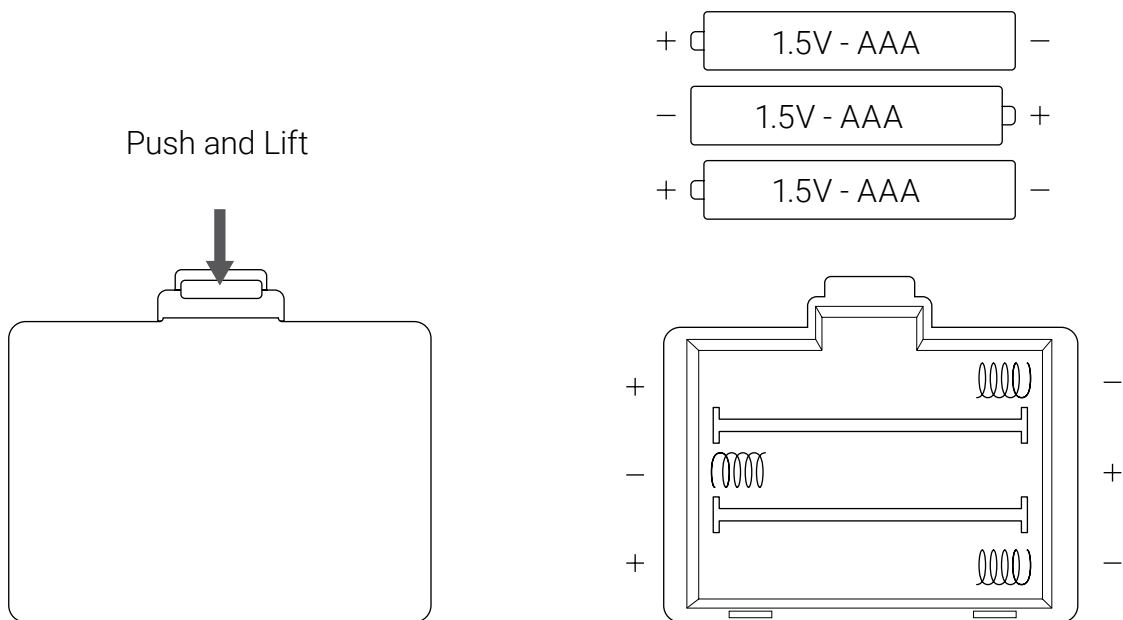

VeSync App Setup

Note: The VeSync app is continually being improved and may change over time. If there are any differences, follow the in-app instructions.

1. To download the VeSync app, scan the QR code or search “VeSync” in the Apple App Store® or Google Play Store.

Note:

- This scale uses the VeSync app, not the VeSyncFit app.
- For Android™ users, you may need to select Allow to use VeSync.



2. Open the VeSync app. If you already have an account, tap **Log In**. To create a new account, tap **Sign Up**.

Note: You must create your own VeSync account to use third-party services and products. These will not work with a guest account. With a VeSync account, you can also allow your family and friends to use your smart body weight scale.



3. Make sure your scale is fully charged.
4. Make sure your phone has Bluetooth® turned on.
5. Tap + in the VeSync app and select your smart body weight scale.
6. Follow the in-app instructions to connect to your smart body weight scale.

Note: You can change the name and icon at any time in the smart body weight scale settings.



Creating a User

If you are a new user, you will need to enter physical information before weighing yourself for the first time so the scale can calculate your body metrics. Follow the in-app instructions to create a user profile.

Note:

- *Entering inaccurate information will make the scale's measurements less accurate.*
- *If you don't identify with the available gender options (or are unsure) pick the option that you think best physically matches you. This choice is used for physical measurements, such as body fat percentages.*



Using the Smart Scale

Note:

- To see your BMI measurement, you must connect the scale to the VeSync app (see page 9).
- If you are pregnant, scale measurements will not be accurate.
- To measure your baby or pet, turn on Baby Mode and follow the in-app instructions for weighing. Baby Mode will not measure other body metrics and will only measure weight and BMI.

1. Place the scale on a hard, flat surface. **[Figure 1.1]**

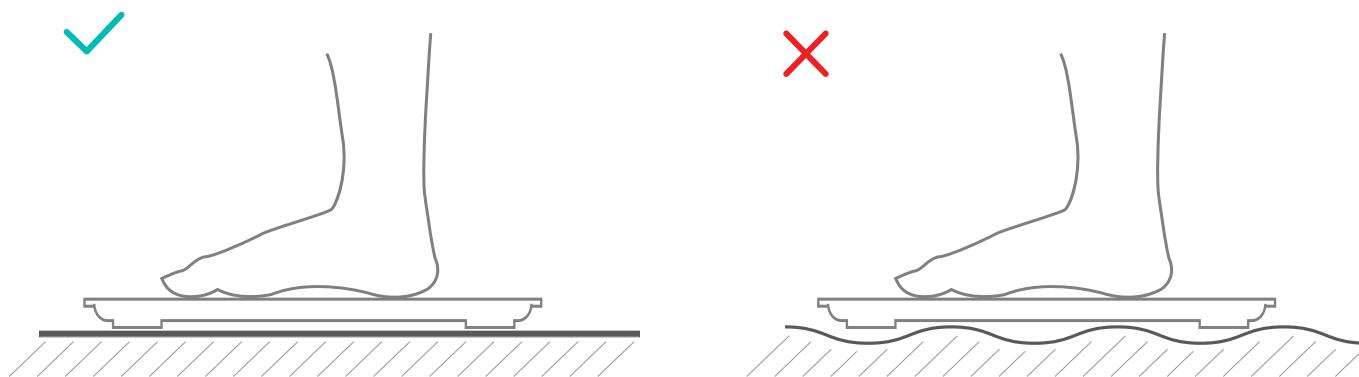

Note: Placing on soft surfaces such as shaggy carpet may cause inaccurate measurements or tipping.

2. Step on the scale, then step off. Wait for the LCD screen to display “00” before using.



[Figure 1.1]



3. Stand on the scale until the display flashes several times, showing your final measurement. **[Figure 1.2]** If your smart scale is connected to the VeSync app, your results (weight and BMI) will show in the app.
4. If you want to measure the weight of your baby or pet using the VeSync app, tap  on the home page and then tap . Follow the in-app instructions.

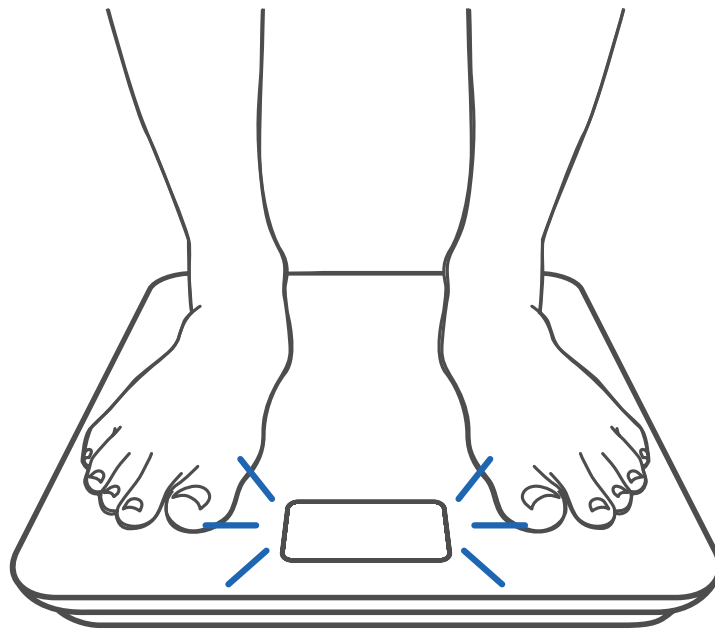

[Figure 1.2]

Switching Units

To switch between pounds (lb), kilograms (kg), and stone (st), open the VeSync app and select the weight unit in the Device Settings menu.



Maintenance

Clearing the Smart Scale

If the scale has been moved or flipped upside down, it must be cleared to ensure accurate results.

1. Place the scale on a hard, flat surface.
2. Step on the scale until digits appear on the display, then step off. [\[Figure 2.1\]](#)
3. The scale will show “00” when cleared. [\[Figure 2.2\]](#)

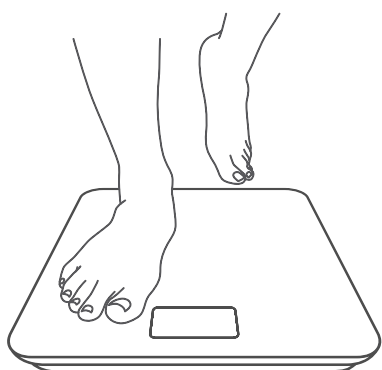

[\[Figure 2.1\]](#)



[\[Figure 2.2\]](#)



Cleaning the Smart Scale

- Use a slightly damp cloth to clean the surface of the scale, followed by a soft, dry cloth to wipe away any remaining moisture.
- **Do not** use chemical or abrasive cleaning agents to clean the scale.

Replacing the Batteries

The display will show “” when the batteries need to be replaced.

1. Open the battery compartment on the underside of the scale.
2. Remove the old batteries and dispose of them properly.
3. Install 3 new 1.5V AAA batteries, making sure they are placed under the correct polarity.
4. Replace the battery compartment cover.

Note: *The scale may need to be cleared after replacing the batteries.*



Common Display Codes



Bluetooth Connection



No Bluetooth Connection



Clearing



Overload



Change Battery



Troubleshooting

The scale doesn't turn on.

- Check if the batteries are properly installed. If using the scale for the first time, remove the plastic insulator strip from the battery compartment.

Information flashes on the display and then disappears.

- The batteries are low and may need to be replaced.

The smart scale doesn't connect with the VeSync app.

- Make sure your phone's operating system is running on iOS® 10.0+ or Android 5.0+.
- Close and relaunch the VeSync app. Make sure you're using the latest version.
- Make sure your phone has Bluetooth turned on. For Android users, make sure your Location is turned on as well.
- Make sure your scale and phone are within 30 ft / 10 m of each other.
- Make sure the scale is not currently connected to any other phone or app.
- Try turning off any VPN apps.



The scale readings seem unstable or inaccurate.

- Make sure the scale is on a hard, flat surface.
- Reset the scale to zero (see page 14).

My scale will only measure my weight, not my BMI.

- Set up your smart scale in the VeSync app. Your weight will show on the scale display, and your weight and BMI will show on the app.
- Make sure Bluetooth is turned on.

***Note:** If the scale has errors on the display, will not turn off automatically, or has a problem not listed here, try removing the batteries for 3 seconds, then replacing them. If the problem is not resolved, replace the batteries with new ones.*

If you still need help, please contact **Customer Support**
(page 23).



Attributions

iOS is a registered trademark of Cisco Systems, Inc. and/or its affiliates in the United States and certain other countries.

App Store is a trademark of Apple Inc.

Google, Android, and Google Play are trademarks of Google LLC.

The Bluetooth® word mark and logos are registered trademarks owned by Bluetooth SIG, Inc. and any use of such marks by Etekcity Corporation is under license. Other trademarks and trade names are those of their respective owners.



Federal Communication Commission

Interference Statement – Part 15

This device complies with Part 15 of the FCC Rules. Operation is subject to the following two conditions:

- (1) This device may not cause harmful interference, and
- (2) This device must accept any interference received, including interference that may cause undesired operation.

NOTE: This equipment has been tested and found to comply with the limits for a Class B digital device, pursuant to Part 15 of the FCC Rules. These limits are designed to provide reasonable protection against harmful interference in a residential installation. This equipment generates, uses and can radiate radio frequency energy and, if not installed and used in accordance with the instructions, may cause harmful interference to radio communications. However, there is no guarantee that interference will not occur in a particular installation. If this equipment does cause harmful interference to radio or television reception, which can be determined by turning the equipment off and on, the user is encouraged to try to correct the interference by one or more of the following measures:

- Reorient or relocate the receiving antenna.
- Increase the separation between the equipment and receiver.
- Connect the equipment into an outlet on a circuit different from that to which the receiver is connected.
- Consult the dealer or an experienced radio/TV technician for help.

FCC Caution: Any changes or modifications not expressly approved by the party responsible for compliance could void the user's authority to operate this equipment.

FCC Radiation Exposure Statement

This equipment complies with FCC radiation exposure limits set forth for an uncontrolled environment. End users must follow the specific operating instructions for satisfying RF exposure compliance. To maintain compliance with FCC RF exposure compliance requirements, please follow operation instructions as documented in this manual. This transmitter must not be co-located or operating in conjunction with any other antenna or transmitter. The availability of some specific channels and/or operational frequency bands are country dependent and are firmware programmed at the factory to match the intended destination. The firmware setting is not accessible by the end user.

Warranty Information

| | |
|---|--------------------------------|
| Product | <i>Smart Body Weight Scale</i> |
| Model | <i>ESB-591</i> |
| For your own reference, we strongly recommend that you record your order ID and date of purchase. | |
| Order ID | |
| Date of Purchase | |

TERMS & POLICY

Etekcitey Corporation (“Etekcitey”) warrants this product to the original purchaser to be free from defects in material and workmanship, under normal use and conditions, for a period of 2 years from the date of original purchase.

Etekcitey agrees, at our option during the warranty period, to repair any defect in material or workmanship or furnish an equal product in exchange without charge, subject to verification of the defect or malfunction and proof of the date of purchase.

There is no other express warranty. This warranty does not apply:

- If the product has been modified from its original condition;
- If the product has not been used in accordance with directions and instructions in the user manual;
- To damages or defects caused by accident, abuse, misuse or improper or inadequate maintenance;
- To damages or defects caused by service or repair of the product performed by an unauthorized service provider or by anyone other than Etekcitey;
- To damages or defects occurring during commercial use, rental use, or any use for which the product is not intended;
- To damages or defects exceeding the cost of the product.

Etekcitec will not be liable for indirect, incidental, or consequential damages in connection with the use of the product covered by this warranty.

This warranty extends only to the original consumer purchaser of the product and is not transferable to any subsequent owner of the product regardless of whether the product is transferred during the specified term of the warranty.

This warranty does not extend to products purchased from unauthorized sellers. Etekcitec's warranty extends only to products purchased from authorized sellers that are subject to Etekcitec's quality controls and have agreed to follow its quality controls.

All implied warranties are limited to the period of this limited warranty.

This warranty gives you specific legal rights and you may also have other rights which vary from state to state. Some states do not allow the exclusion or limitation of incidental or consequential damages, so the above limitation or exclusion may not apply to you.

If you discover that your product is defective within the specified warranty period, please contact Customer Support via **support@etekcity.com**. **DO NOT** dispose of your product before contacting us. Once our Customer Support Team has approved your request, please return the product with a copy of the invoice and order ID.

Every Etekcitec product automatically includes a 2-year warranty. To make the customer support process quick and easy, register your product online at www.etekcity.com/warranty.

This warranty is made by:

Etekcitec Corporation
1202 N. Miller St., Suite A
Anaheim, CA 92806



Customer Support

If you have any questions or concerns about your new product, please contact our helpful Customer Support Team.

Etekcity Corporation

1202 N. Miller St., Suite A
Anaheim, CA 92806

Email: support@etekcity.com

Toll-Free: (855) 686-3835

Support Hours

Mon–Fri, 9:00 am–5:00 pm PST/PDT

**Please have your invoice and order ID ready before contacting Customer Support.*





Connect with us @Etekcinity

