

KARISMA® B E A U T Y D E S I G N

INSTRUCTIONS FOR INSTALLATION, USE AND
ROUTINE MAINTENANCE



CHARLY CLOUD WASH UNIT

K7614_K7615

CONTENTS

INTRODUCTION	3
PREREQUISITES	4
INTENDED USE	4
INSTRUCTIONS FOR USE	4
DEFINITION	4
SAFETY	4
ELECTRICAL SPECIFICATIONS	5
MIXER SPECIFICATIONS	5
THERMOSTATIC MIXER SPECIFICATIONS	5
TRANSPORT AND STORAGE	6
DIMENSIONS	6
INSTALLATION SURFACE	7
PREPARATION	9
WASH UNIT ATTACHMENT	9
FLOOR DRAIN	10
WALL DRAIN	11
ELECTRICAL CONNECTION	12
TESTING	13
USE	13
SWITCHING ON THE EQUIPMENT	13
RELAX CONTROLS	14
JET MASSAGE CONTROLS	15
ROUTINE MAINTENANCE	16
CHAIR	16
WASHBASIN UNIT	16
CLEANING THE SURFACES	17
ELECTRICAL FUNCTIONS	18
IDENTIFICATION OF THE EQUIPMENT	18
INSTRUCTIONS FOR DISPOSAL	18

INTRODUCTION

Thank you for purchasing a Karisma product. We are certain you will be fully satisfied with your choice.

Karisma products are manufactured according to strict quality standards using only the best components.

The operation and safety of each wash unit were tested in painstaking detail before shipment.

Check that the wash unit was not damaged during transport in a manner that could impair its operation and safety.

You are advised to follow the instructions contained in this manual carefully for the best reliability, long life and top-notch performance of the wash unit.

The manual is designed to allow you to use the wash unit in the best and safest manner.

Therefore, this manual is an integral part of the wash unit. It must be kept carefully throughout the duration of the wash unit and accompany the wash unit if it is transferred to a new user.

To avoid problems, read this manual carefully before carrying out any operation on the wash unit and follow the instructions scrupulously.

The manufacturer accepts no liability for damage caused by negligence and/or failure to observe the instructions in this manual.

Without prejudice to the main technical and safety features of the product, the manufacturer reserves the right to make changes to the wash unit for reasons of continual technical and technological evolution without prior notice, without incurring any penalty.

The partial or total reproduction of this manual, including texts and illustrations, is prohibited by law.

The Court of Reggio Emilia (Italy) is competent in case of disputes.

PREREQUISITES

The following requirements must be observed for a correct and safe installation of the equipment:

- 1) The floor must comply with **DIN 1055 B 1.3** and **DIN 18560 T 1**.
- 2) The electrical system must comply with **CEI 64.4** standards, using **250V/16A** differential protection conductors (<30mA).
- 3) Do not connect devices that are not specified as part of the system.
- 4) Earthing, in particular, must comply with **Article 3.2.01** of the aforementioned standards.
- 5) The equipment must be fixed to the floor using anchor bolts with a minimum diameter of 8 mm.

The manufacturer is not liable for the safety and reliability of the equipment if:

- **installation and repairs are not carried out by authorised technicians**
- **the general and electrical installation of the room does not comply with the requirements indicated above**
- **the device was not installed following this manual**
- **the device is not used following this manual.**

INTENDED USE

The wash unit chair is intended for professional use in hair treatment salons, particularly in the hair washing area.

INSTRUCTIONS FOR USE

The wash unit chair is intended for professional use in hair treatment salons, particularly in the hair washing area. It cannot be used by more than one operator at the same time and can accommodate only one customer at a time. The maximum load capacity is 120 kg. The equipment must be fixed to the floor. The installation is compliant if carried out according to the specifications indicated in the Installation, Use and Maintenance Manual. The equipment must be fixed with anchor bolts with a minimum diameter of 8 mm. Sitting on the worktops and armrests is not permitted. Multiple people are not allowed to sit together. It is not allowed to get seated and/or get up while the footrest is moving or if the chair being raised.

Beware of scalding caused by hot water.

Beware of moving parts of the wash unit chair.

DEFINITIONS

Hairdresser, or operator, is the person who performs the treatment of the customer's hair and who manages the operation of the wash unit chair. The workstation is situated at the back of the wash unit chair.

Customer is the person who is receiving the hair treatment. The front part of the wash unit chair is used to seat the customer.

SAFETY



The equipment complies with the essential European Union regulations on ergonomics and safety. The manufacturer guarantees these qualities by affixing the CE marking.

ELECTRICAL SPECIFICATIONS

Wash unit model	Rated voltage	Rated frequency	Rated power	Intermittent operating mode
Electric CHARLY CLOUD Relax Code K7614	220V ~ ±10%	50/60 Hz	220VA	3 min. ON 5 min. OFF
CHARLY CLOUD Jet Massage Code K7615	220V ~ ±10%	50/60 Hz	250VA	8 min. ON 5 min. OFF

MIXER SPECIFICATIONS

Technical specifications

Test pressure **15 bar**

Cold water supply blue indicator pointing rightwards. Pipe connection 3/8"

Hot water supply red indicator pointing leftwards. Pipe connection 3/8"

Limits of use according to UNI 10234 EN (817):

MIN. pressure 0.5 bar MAX. 10 bar (10000000 pascals)

MAX. temperature 90°

Limits of use recommended by UNI 10234 (EN 817) for a good tap operation

Pressure: **MIN. 0.5 bar MAX. 5 bar (5000000 pascals)**

Temperature: **MAX. 65°C**

Warnings:

- The system pipes must be carefully rinsed to avoid damage to the taps caused by any residues in the pipes.
- It is recommended to install a pressure reducer in case of operating pressures above 5 bar.
- It is also recommended to install a central filter for water with a high impurity content.

THERMOSTATIC MIXER SPECIFICATIONS

Technical specifications

Test pressure **15 bar**

Cold water supply blue indicator pointing rightwards. 1/2" pipe connection

Hot water supply red indicator pointing leftwards. 1/2" pipe connection

Limits of use according to UNI 10234 EN (817):

MIN. pressure 1 bar MAX. 10 bar (10000000 pascals)

MAX. temperature 90°

Limits of use recommended by UNI 10234 (EN 817) for a good tap operation

Pressure: **MIN. 1 bar MAX. 5 bar (5000000 pascals)**

Temperature: **MAX. 65°C**

Warnings:

- The system pipes must be carefully rinsed to avoid damage to the taps caused by any residues in the pipes.
- It is recommended to install a pressure reducer in case of operating pressures above 5 bar.
- It is also recommended to install a central filter for water with a high impurity content.

TRANSPORT AND STORAGE

The packages must be transported on closed vehicles. Do not drop or tilt packages during loading and unloading. The products must be stored in a dry, indoor place, stacking up to three packages on top of each other and without drastic temperature changes.

Environmental conditions for transport and storage

- Ambient temperature from -25°C to $+50^{\circ}\text{C}$.
- Relative humidity max 75%.

Environmental conditions of use

- Ambient temperature from $+10^{\circ}\text{C}$ to $+40^{\circ}\text{C}$.
- Relative humidity from 30% to 75%.

DIMENSIONS

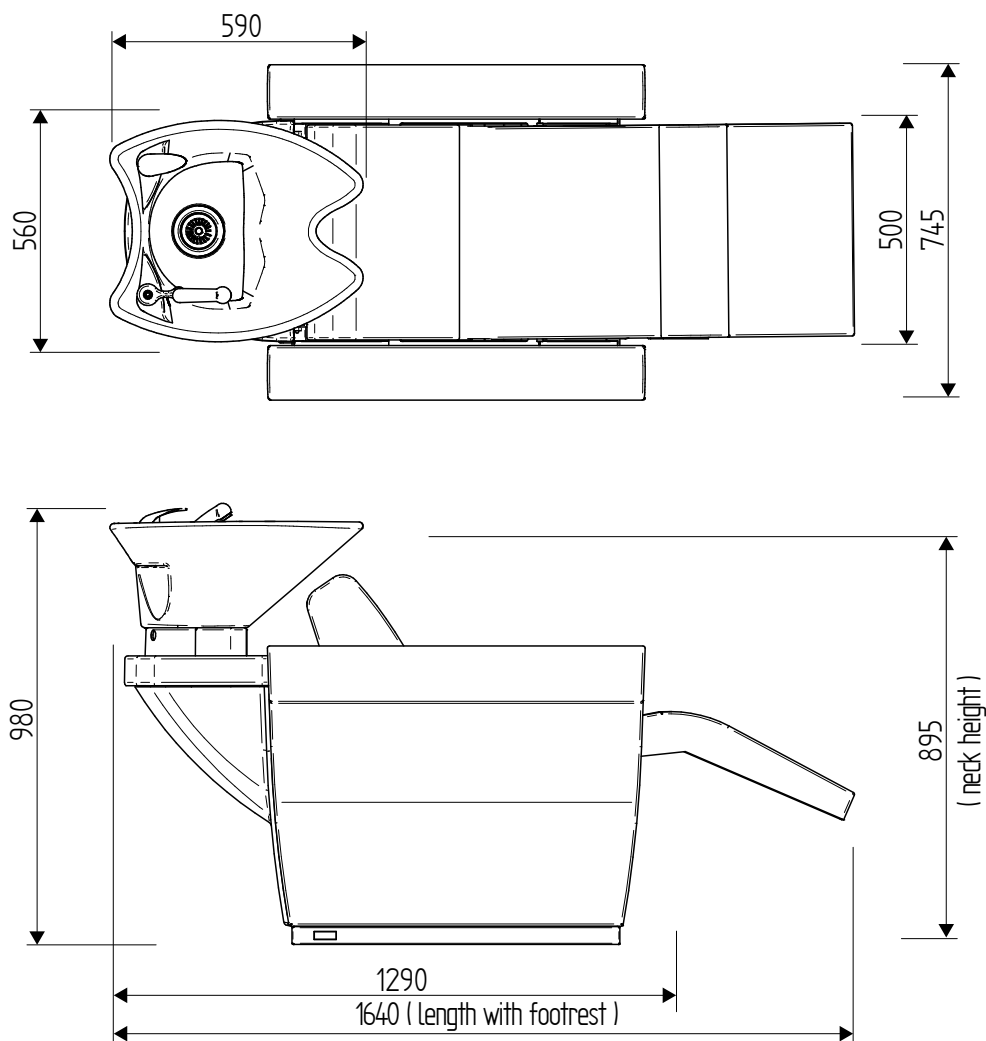

Dimensions in mm.

INSTALLATION SURFACE

WARNING: Open the side panel before fixing the wash unit in a side-by-side arrangement with a side drain.

Plant layout

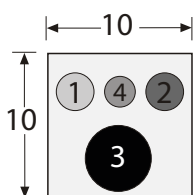

- 1 = Hot 3/8" (1/2" thermostatic mixer)
- 2 = Cold 3/8" (1/2" thermostatic mixer)
- 3 = \varnothing 40 mm drain
- 4 = Electrical cable outlet (where required)
Cord 3X1 (1500 mm) - 220/240 V - 50 Hz/60 Hz

Important note The grey areas delimit the space available for installation.

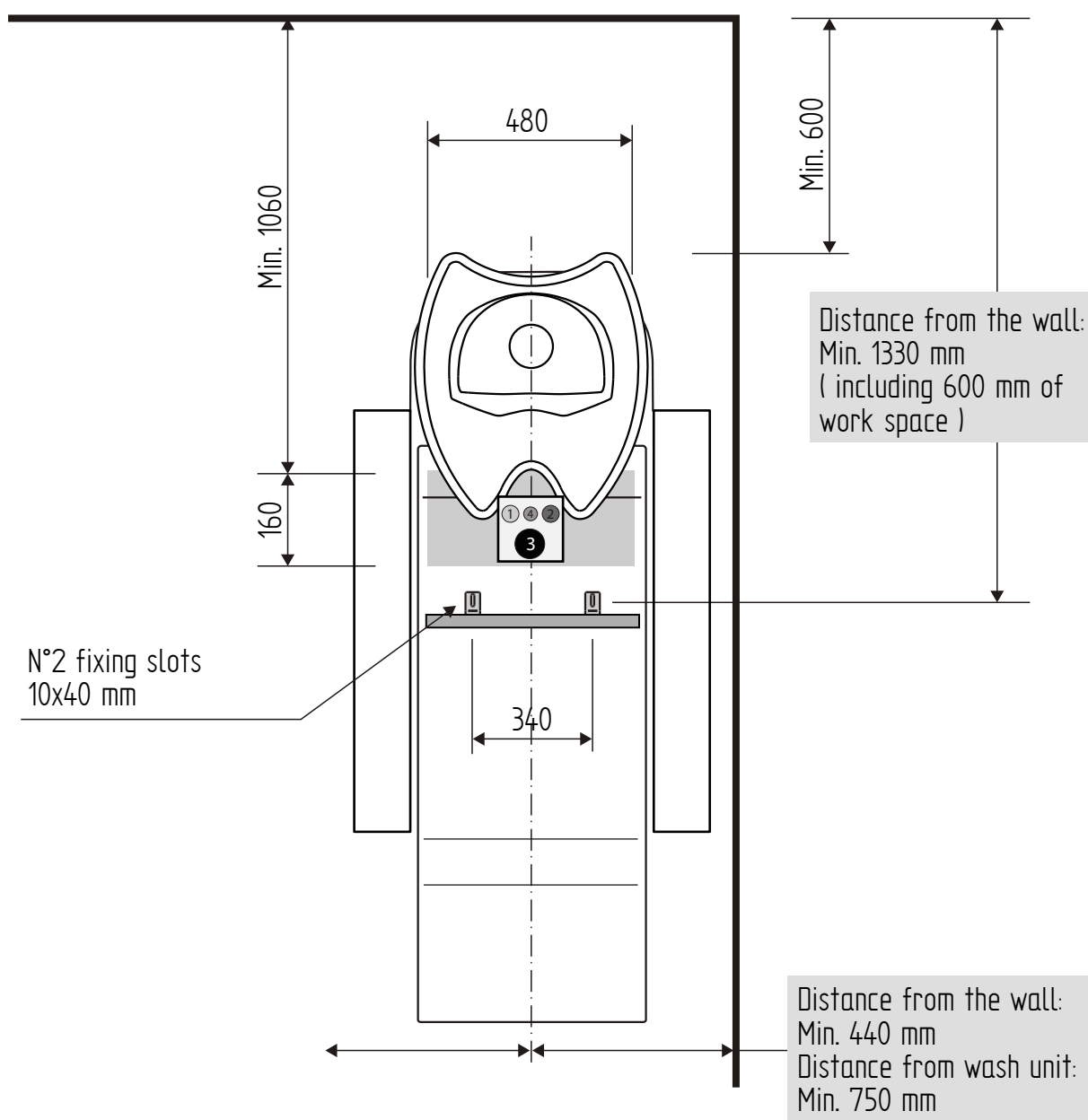

INSTALLATION SURFACE

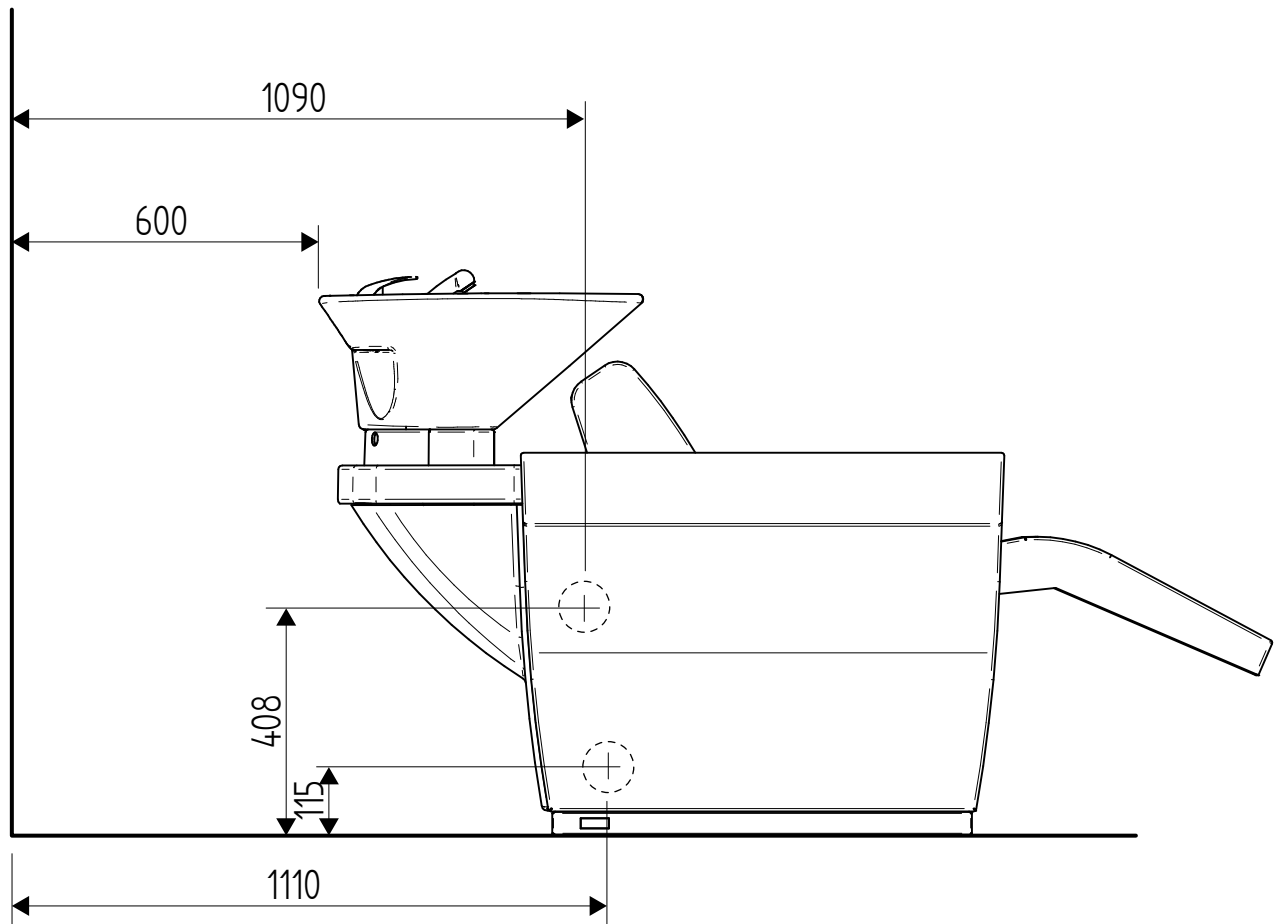

Dimensions in mm.

INSTRUCTIONS

- 1 = Determine the height of the wall drain from the ground.
- 2 = Open the rear wash unit casing.
- 3 = Locate the pre-existing slot on the **inside** of the shoulder and drill a centring hole at the detected height.
- 4 = Fix the supplied flange with the appropriate screws on the **outside** of the shoulder.
- 5 = Open the side panel.

INSTALLATION

Preparation

- 1) Remove the packaging leaving the wash unit mounted on the pallet so that it is easier to transport. Remove the wash unit protections and any accessories contained in the packaging itself.
- 2) Position the wash unit and mark the fixing points (Fig. 2). Drill holes for the anchor bolts.

Fixing the wash unit

WARNING: Prepare the holes for the drain and electrical power supply, if applicable before fixing the wash units, either in side-by-side arrangement or with side drain.

- 1) Undo the screws (1) fastening the rear casing.

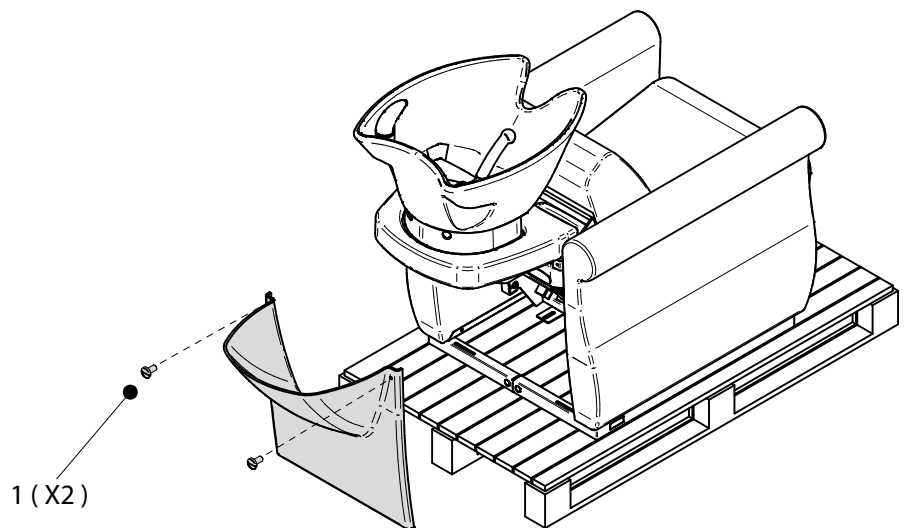

- 2) Undo the two screws fixing the wash unit to the pallet (2) and position the wash unit in the spot prepared for installation.

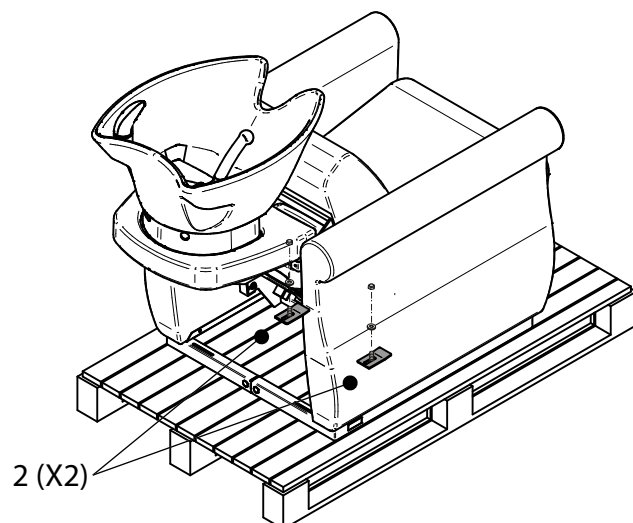

3) Place the two nylon discs supplied (1) under the base of the wash unit and fix it to the floor with the anchor bolts suitable for the type of material of which the floor is made using the four holes provided for the purpose.

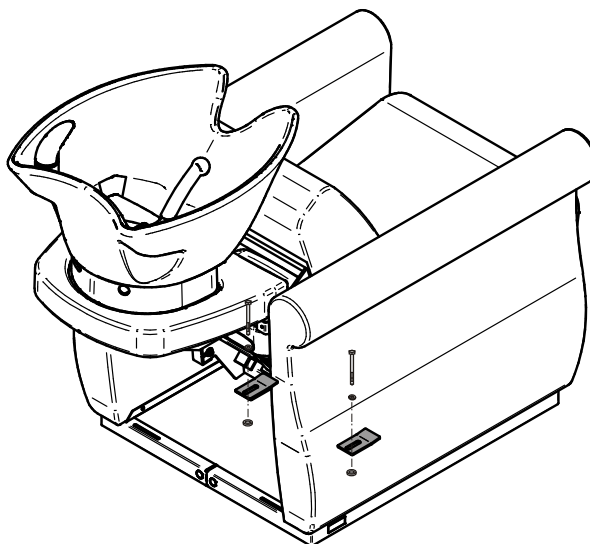

INSTALLATION

Floor drain

WARNING:

The water connection may only be carried out by qualified technicians

Open the side panel (Point 2) if the installation requires infeed of the power supply from the wall or in a side-by-side arrangement.

1) Install the water unit using $\varnothing 3/8''$ hydraulic connections ($1/2''$ if thermostatic). It is advisable to provide a gate valve upstream of each fitting.

Connections to the sewage system are established using a $\varnothing 40$ drain pipe.

Plant layout

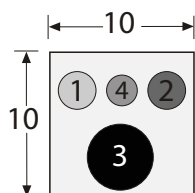

1 = Hot $3/8''$

2 = Cold $3/8''$

3 = $\varnothing 40$ mm drain

4 = Electrical cable outlet (where required)

Cord 3X1 (1500 mm) - 220/240 V - 50 Hz/60 Hz

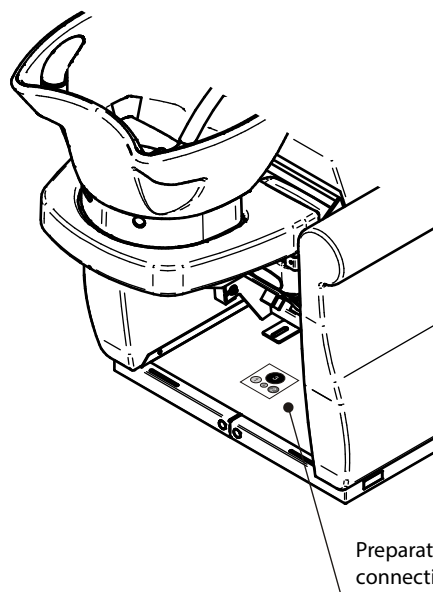

2) Opening the side panel

1 = Determine the height of the wall drain from the ground

2 = Open the rear wash unit casing.

3 = Locate the pre-existing slot on the inside of the shoulder and drill a centring hole at the detected height.

4 = Fix the supplied flange with the appropriate screws on the outside of the shoulder.

5 = Open the side panel

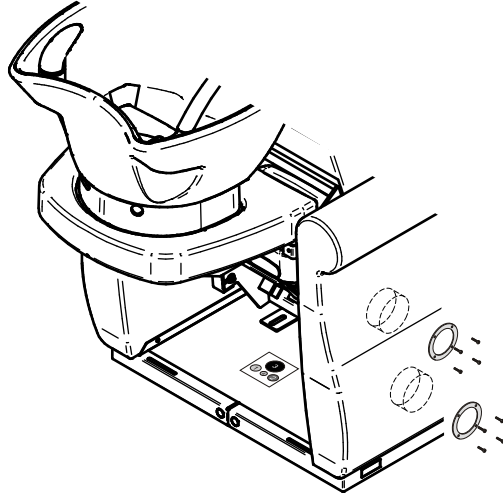

INSTALLATION

Wall drain

WARNING:

The water connection may only be carried out by qualified technicians

Open the side panel if the installation requires a power supply inlet from the wall or in a side-by-side arrangement.

1) Opening the side panel

1 = Determine the height of the wall drain from the ground

2 = Open the rear wash unit casing.

3 = Locate the pre-existing slot on the inside of the shoulder and drill a centring hole at the measured height.

4 = Fix the supplied flange with the appropriate screws on the outside of the shoulder.

5 = Open the side panel.

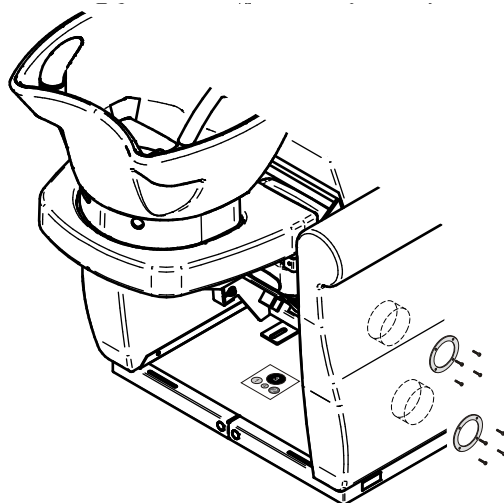

2) Install the water unit using \varnothing 3/8" hydraulic connections (1/2" if optional thermostatic). It is advisable to provide a gate valve upstream of each fitting.

Connections to the sewage system are established using a \varnothing 40 drain pipe.

Plant layout

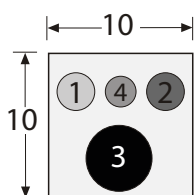

- 1 = Hot 3/8"
 - 2 = Cold 3/8"
 - 3 = \varnothing 40 mm drain
 - 4 = Electrical cable outlet (where required)
- Cord 3X1 (1500 mm) - 220/240 V - 50 Hz/60 Hz

Preparation for water connection

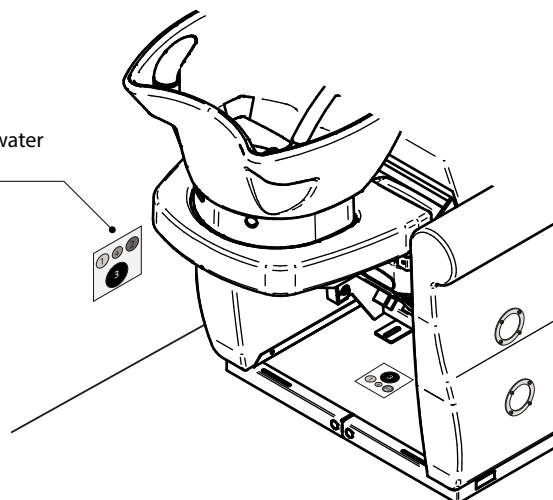

ELECTRICAL CONNECTION

WARNING:

The electrical connection may only be carried out by qualified technicians

Check that the electrical system complies with Points 2 and 4 of the PREREQUISITES on page 4.

It is advisable to provide an automatic switch and disconnecter to cut off power to the wash units at any time.

1) The wash unit models that require an electrical power supply are equipped with a 3x1, 1.5 m long cord with a Schuko plug. Plug it into the socket.

2) By opening the junction box (fig. 1) of the wash unit, it is possible to connect the mains wires directly to the terminal board N⊕L (fig.2).

(fig. 1)



(fig. 2)



3) **WARNING:** The seat can move on some models. Make sure that the cables are not pulled (or can be pulled when the seat is moved) when connecting the wash unit. Also, make sure that they are not close to moving mechanisms.

TESTING

Once the connection has been established, test all the functions of the equipment, preferably with a person sitting in the chair:

- footrest all up
- footrest all down
- full cycle of the massage function
- cold water (mixer all open with the lever all to the left)
- hot water (mixer all open with the lever all to the right)
- drain (partially fill the basin, remove the cap and drain, repeat operation two or three times).

1) After testing, reposition the rear casing using the screws (1).

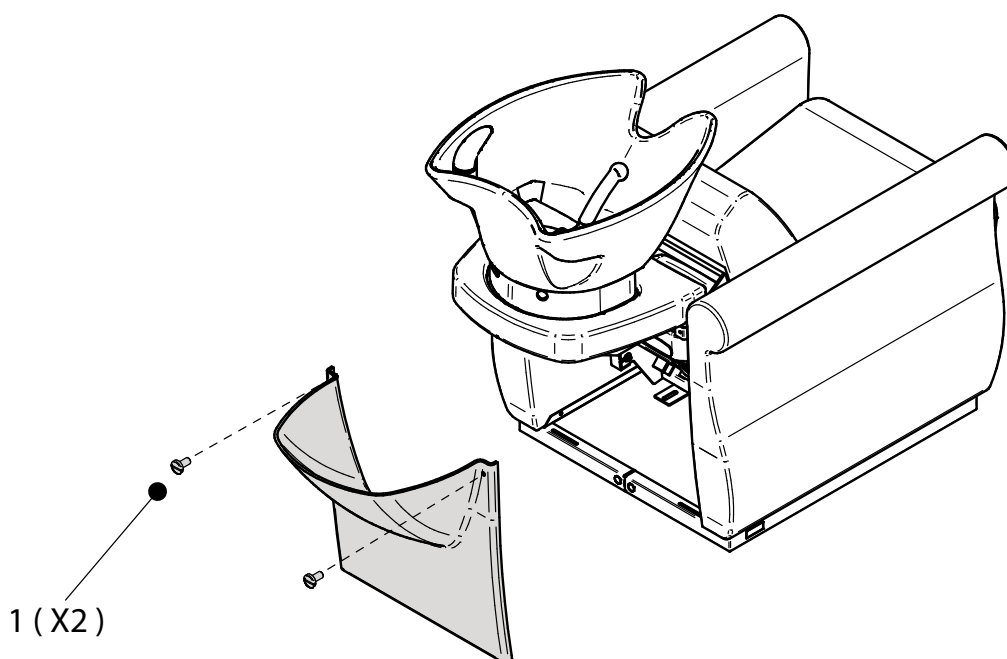

USE

Switching on the wash unit

The wash unit is switched on by plugging it into the power supply.

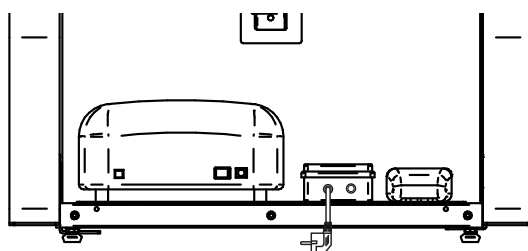

RELAX CONTROLS

Keypad for operating the electric footrest (1)

This keypad can be used to activate the device for adjusting the wash unit footrest.

Foot pedal (optional) for operating the electric footrest (2)

This foot pedal can be used to activate the device for adjusting the wash unit footrest.

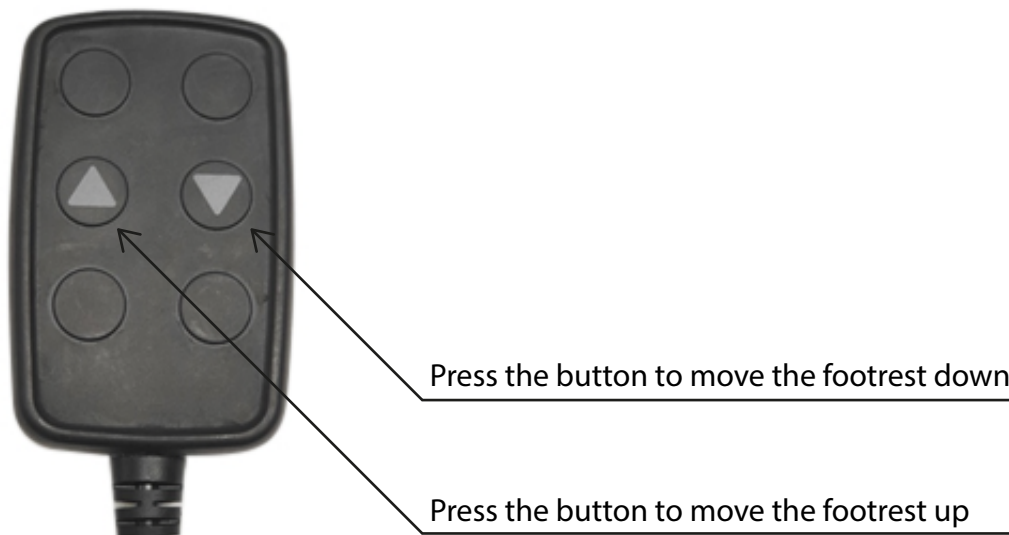

Relax control panel D6510060

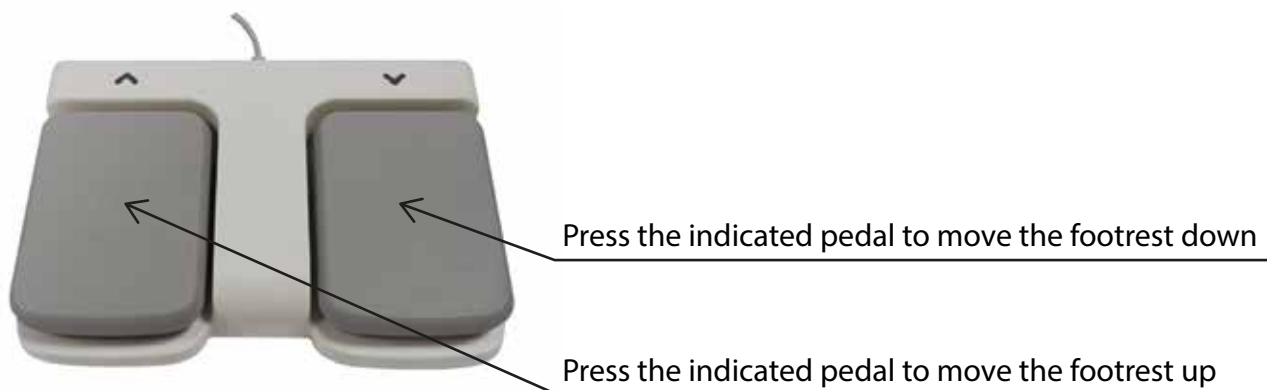

Relax control pedal D5710030 (Optional)

JET MASSAGE CONTROLS

Keypad for operating the jet massage (1)

This keypad can be used to activate the device for adjusting the wash unit footrest and massage.

Foot pedal (optional) for operating the jet massage (2)

This foot pedal can be used to activate the device for adjusting the wash unit footrest and massage.

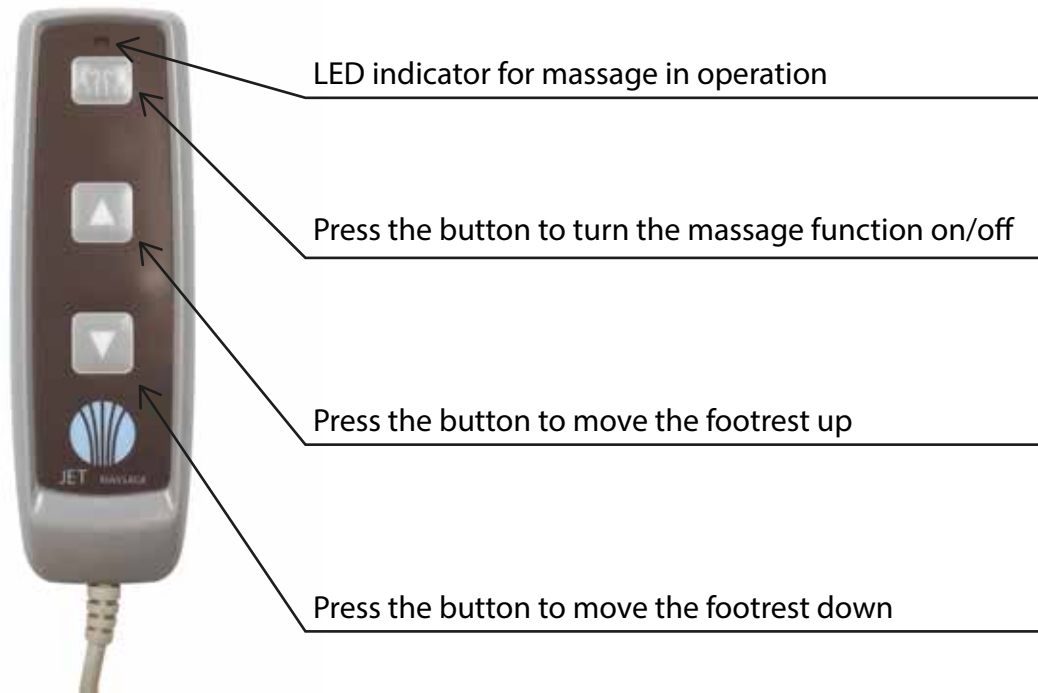

Jet massage control panel C6420007

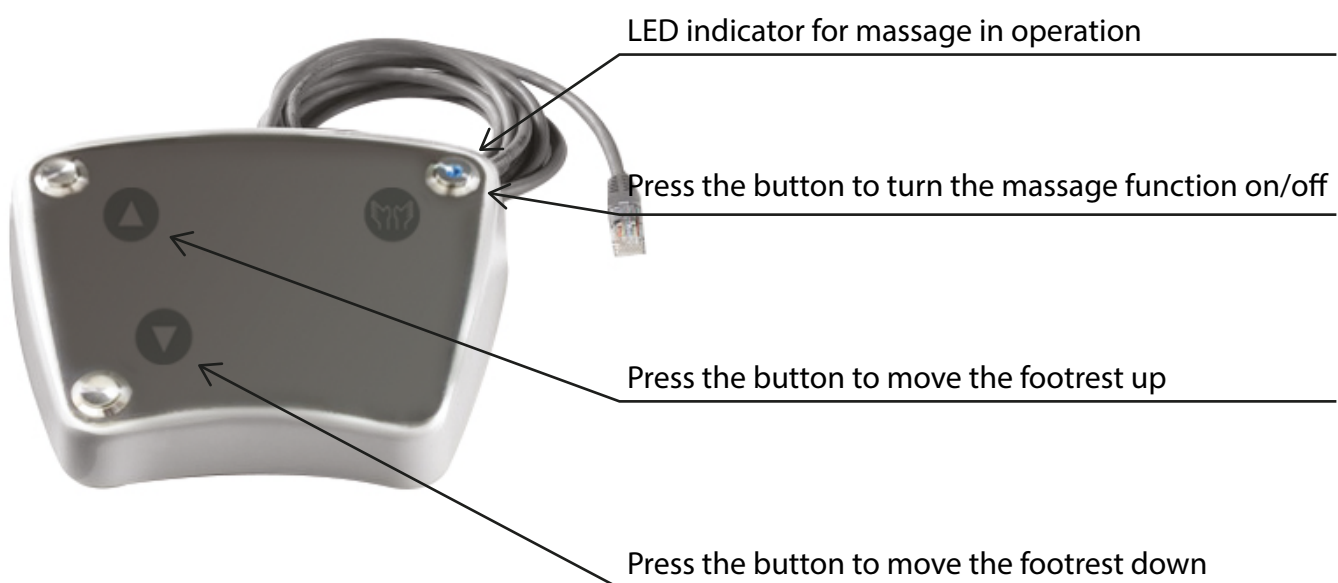

Jet massage control pedal G060040 (Optional)

ROUTINE MAINTENANCE

Chair

- Check the wear condition of the chair every month.
- Check that the side armrests are firmly attached and secure (1) every six months.
- Clean and lubricate moving parts every six months.

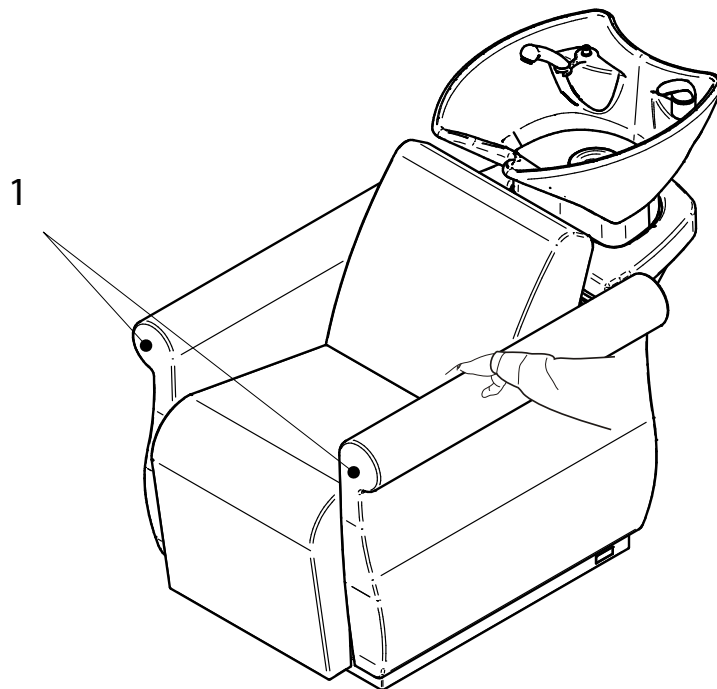

Washbasin unit

- Check every two months that there are no water leaks under the washbasin which could damage the base and the wash unit equipment. To do this, remove the casing of the wash unit by undoing the appropriate screws (1) so that the part under the washbasin is visible.

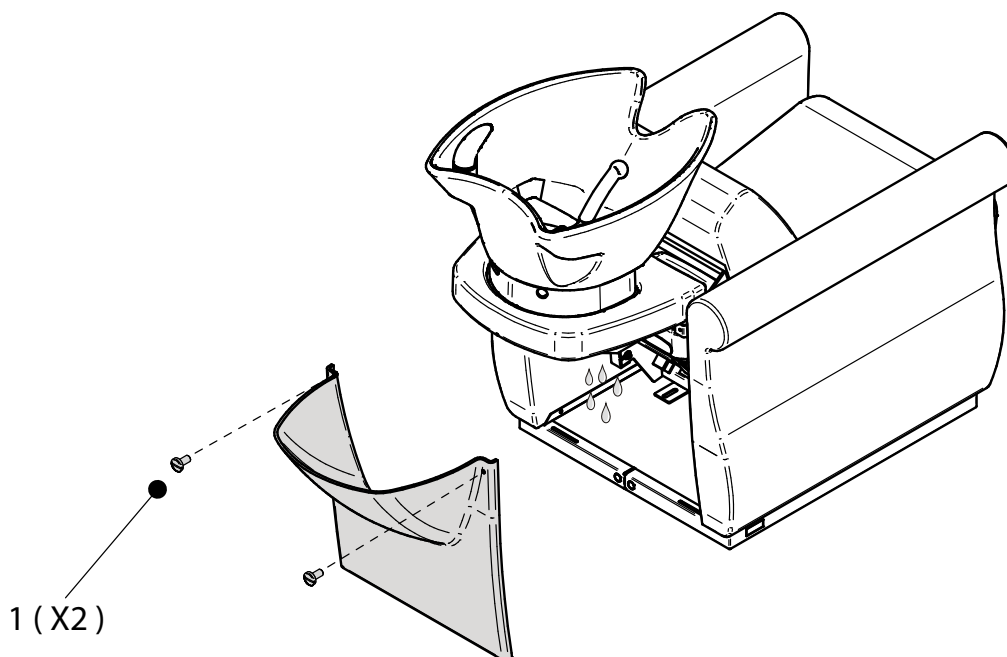

ROUTINE MAINTENANCE

Washbasin unit

- Check the tightness of the oscillating system every two months and, if necessary, tighten the two nuts (2) that adjust the stiffness of the movement of the washbasin to achieve the right friction by turning them clockwise.



Cleaning the surfaces

- Disconnect power to the wash unit before cleaning or doing other jobs.
- Do not use solvents to clean the metal parts. Only use a damp cloth.
- Use only sanitising liquid to clean plastic parts.
- The upholstery of the chair must be cleaned with mild soap and water.
- Do not use alcohol-based products.

Never use aggressive or abrasive cleaning agents.

Please note that the chemicals contained in many hair treatment products can cause permanent stains on plastic surfaces or painted parts that cannot be removed.

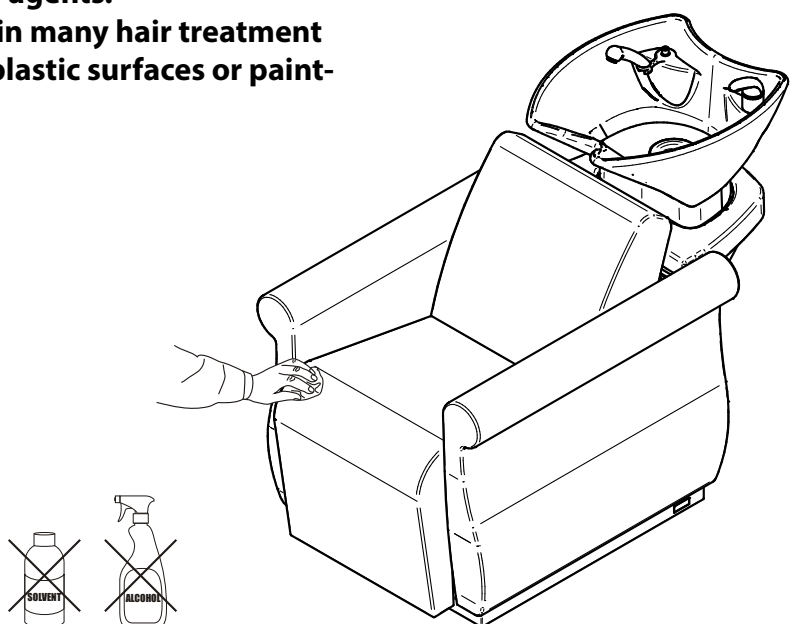

Electrical functions

If the equipment does not work, check that:

the power plug is inserted correctly (check the connection)

the control has not come into contact with water (disconnect the power to the wash unit wait 2 hours and try again)

the control has not been pulled excessively (disconnect the power supply to the wash unit, open the rear casing and check the connection).

Warning:

- **Do not use the equipment in case of water leakage.**
- **If the power cord is damaged, it must be replaced by the manufacturer, a technical assistance technician or qualified personnel to prevent hazards.**

IDENTIFICATION OF THE EQUIPMENT

Always quote the serial number when communicating with the manufacturer or service centres.

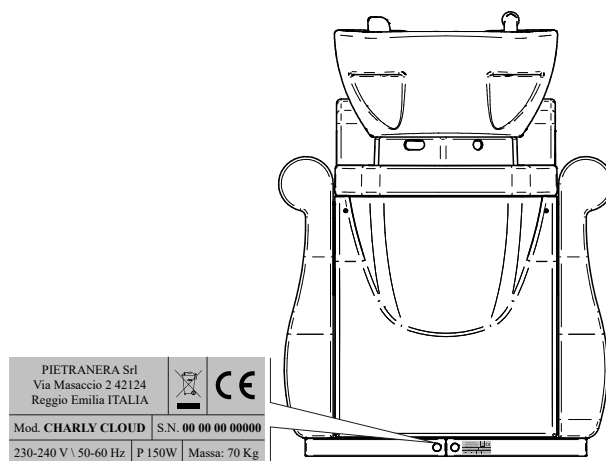

INSTRUCTIONS FOR DISPOSAL



Disposal of packaging

The packaging material is 100% recyclable. The various parts of the packaging must not be dispersed in the environment and must be disposed of following the regulations of your local authorities.



Disposal of end-of-life equipment

Under European Directive 2012/19/EU and the current provisions on waste electrical and electronic equipment as implemented by national law, end-of-life electrical equipment must be collected separately and disposed of in an environmentally compatible recycling plant.

By ensuring that this product is disposed of correctly, you are helping to prevent potential negative consequences for health and the environment.

Please contact your local authority or waste collection service for more information on the treatment, recovery and recycling of this product.



Via Masaccio, 2 - 42124 Reggio Emilia - Italy

+39.0522.237010

Fax. +39.0522.514669

e-mail: info@karismabeauty.com

www.karismabeauty.com