

MR. PAUL WASH RELAX Cod. 410 P

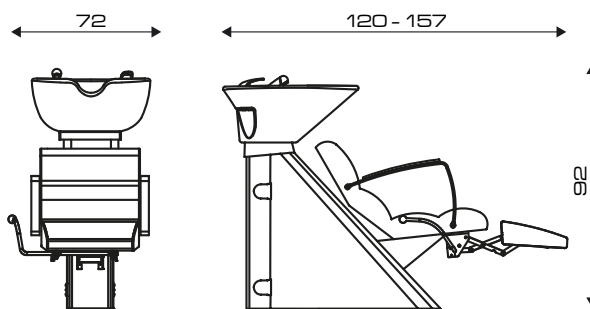

libretto di manutenzione
instructions for use and routine maintenance
instructions pour l'utilisation et l'entretien ordinaire
instrucciones de uso y mantenimiento ordinario



Piano installazione / Installation Plan

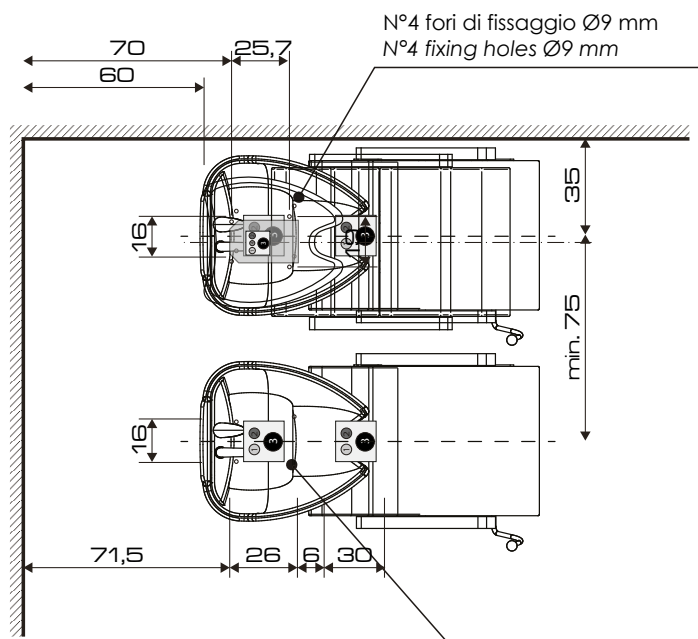

area 26x16 cm + 30x16 cm predisposizione allacciamento idrico
predisposition area 26x16 cm + 30x16 cm water supply

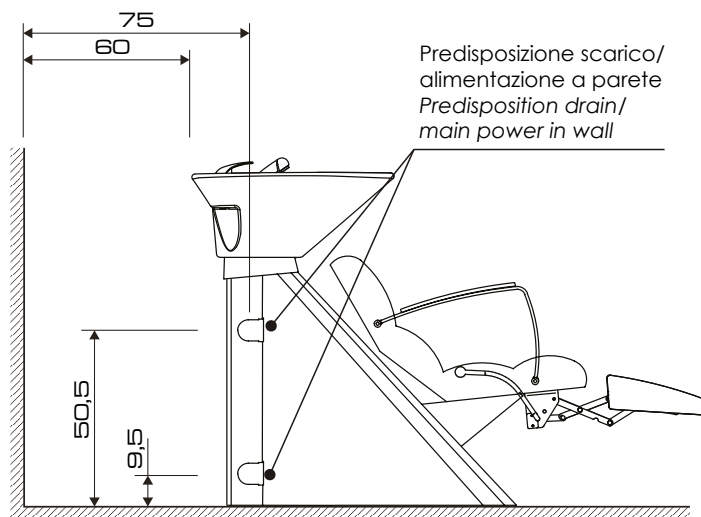

Disposizione impianto idrico / Disposition water supply

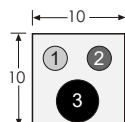

1 = Calda/Warm 3/8" 2 = Fredda/Cold 3/8" 3 = Scarico/Drain ø 4 cm



ATTENZIONE !

Tutte le dimensioni sono espresse in cm. Il lavaggio deve essere fissato a terra con tasselli del diametro minimo di 8mm , come da disposizione della normativa di sicurezza internazionale. E' necessario prevedere un facile accesso alla alimentazione per provvedere a un eventuale distacco in caso di necessità. Il produttore declina ogni responsabilità per eventuali danni ad oggetti e/o persone causati da un'errata installazione idraulica ed elettrica.

WARNING !

All the dimensions are in cm. The wash unit should be fixed to the floor (minimum diameter of 8mm dowels), as specified by modern international safety regulations. It is necessary to provide easy access to the power supply to provide for a possible detachment in case of need. The producer will not accept any responsibility for eventual damage to objects and/or people caused by incorrect installation of the plumbing and electric system.