

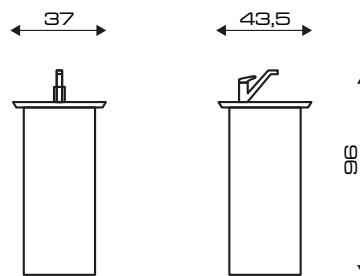

Istruzioni d'installazione  
Installation instructions  
Instructions d'installation  
Instrucciones de montaje  
Montage-anweisungen

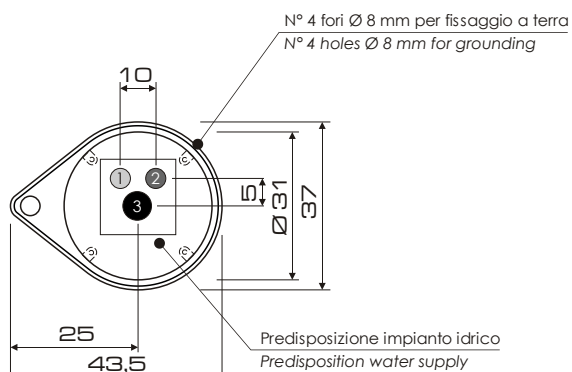

## Piano installazione / Installation Plan

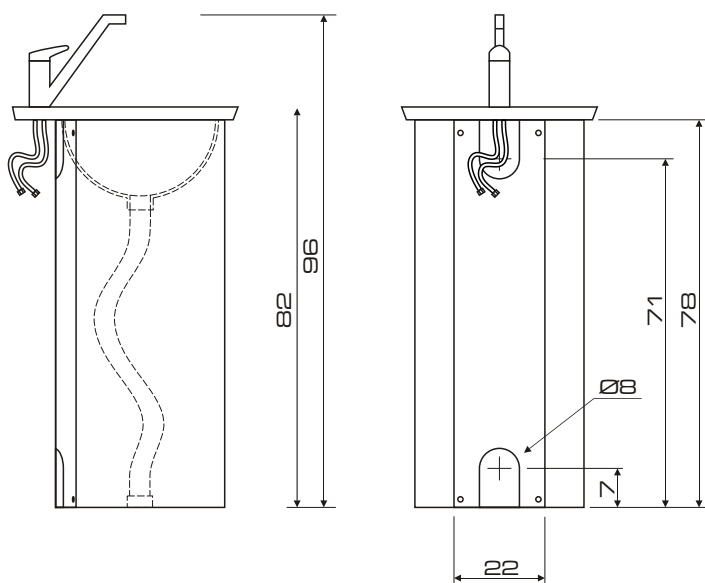

## Disposizione impianto idrico / Disposition water supply

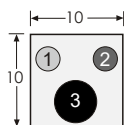

1 = Calda/Warm 3/8"    2 = Fredda/Cold 3/8"    3 = Scarico/Drain ø 4 cm

## Installazione laterale / Side drain installation

Per i collegamenti a parete, sfruttare i due fori predisposti nello sportello. Nell' eventualità di misure diverse forare la struttura in qualunque posizione.

For wall connections, use the two holes provided in the door. In the event of different sizes, drill the structure in any position.



### ATTENZIONE !

Tutte le dimensioni sono espresse in cm. Il lavaggio deve essere fissato a terra con tasselli del diametro minimo di 8mm , come da disposizione della normativa di sicurezza internazionale. E' necessario prevedere un facile accesso alla alimentazione per provvedere a un eventuale distacco in caso di necessità. Il produttore declina ogni responsabilità per eventuali danni ad oggetti e/o persone causati da un'errata installazione idraulica ed elettrica.

### WARNING !

All the dimensions are in cm. The wash unit should be fixed to the floor ( minimum diameter of 8mm dowels ) , as specified by modern international safety regulations. It is necessary to provide easy access to the power supply to provide for a possible detachment in case of need. The producer will not accept any responsibility for eventual damage to objects and/or people caused by incorrect installation of the plumbing and electric system.