

**Product Codes:**

- 05250 - Duke Barbers Unit (inc. Basin)
- 05251 - Duke Link Unit

**Standard Equipment:**

- Large upper mirror
- Stainless steel anti-scratch work top
- Basin & mixer valve (05250)
- Drawer storage (05251)

**Optional Equipment:**

- 05254 - Holster plate

**Main Construction:**

- Timber construction finished in high pressure laminate from the REM laminate range
- Mirror fixed to backboard, black edged

**Finish:**

- Any laminate from the REM swatch range

**Features:**

- Stainless steel work tops
- Removable lower panel for plumbing access
- Link unit available

Laminate Finish Options:

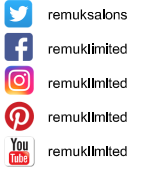
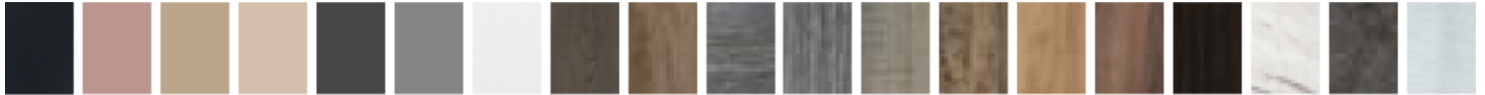

05250 - Duke Barbers Unit (inc. Basin)

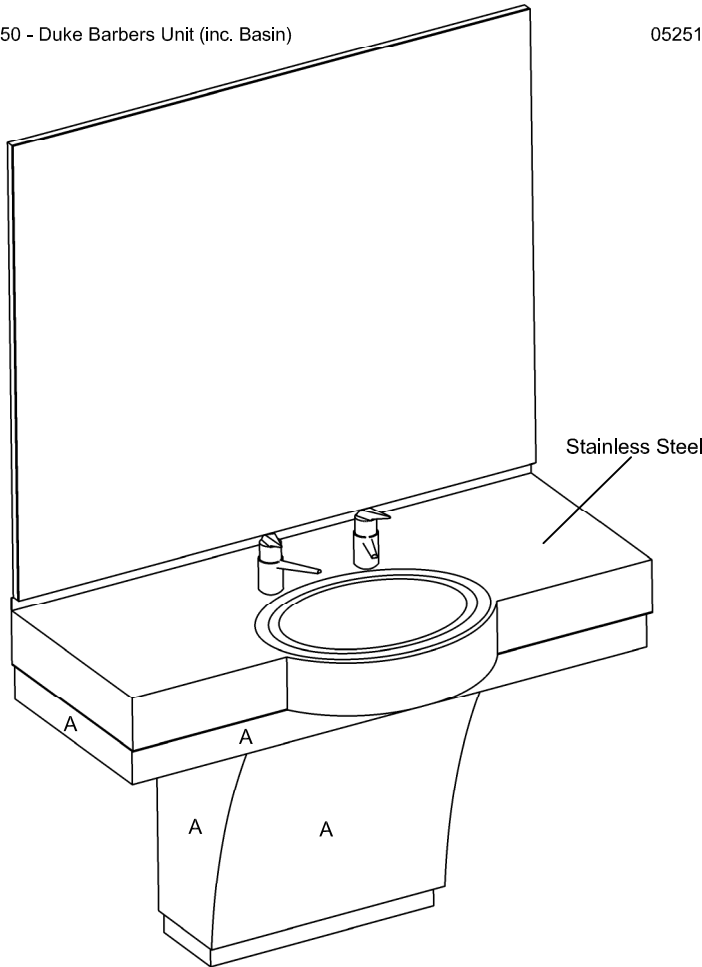

05251 - Duke Link Unit

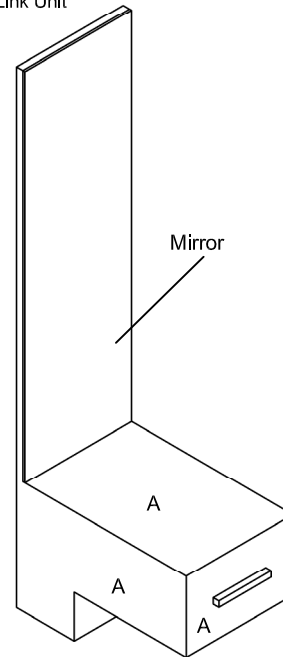

A = Laminate

Choice of REM laminates

Optional extras must be clearly detailed at time of order.

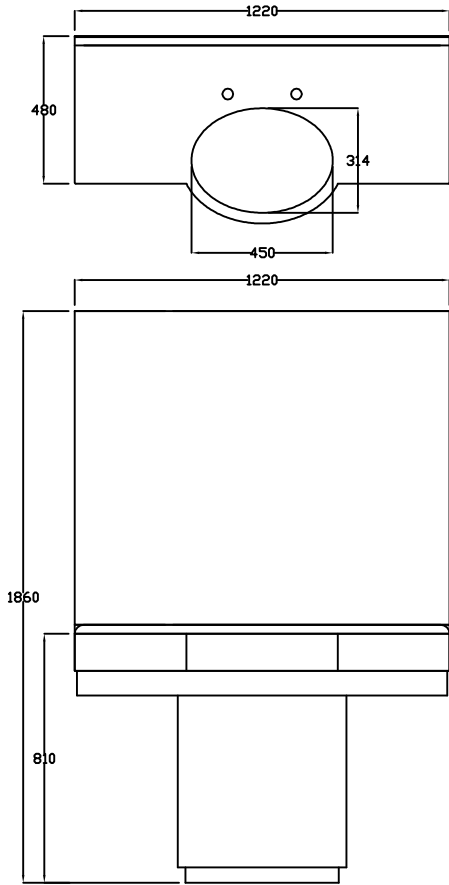

05250 - Duke Barbers Unit (inc. Basin)

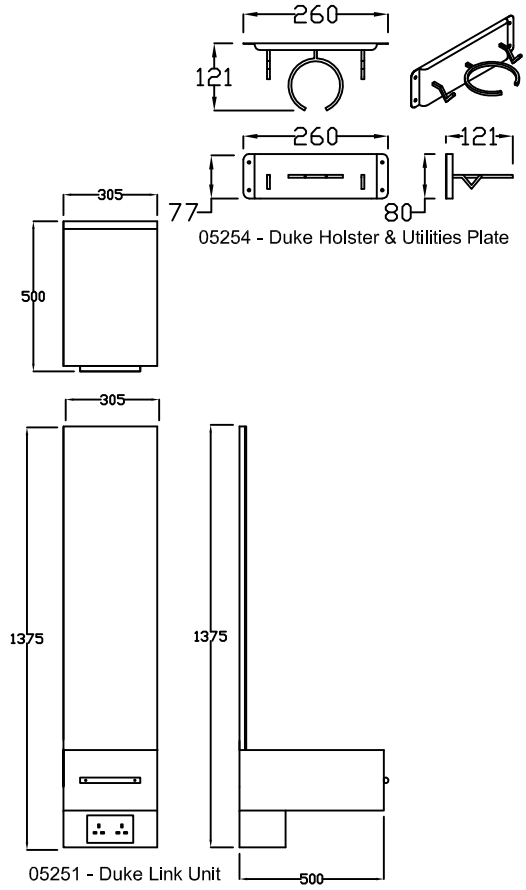
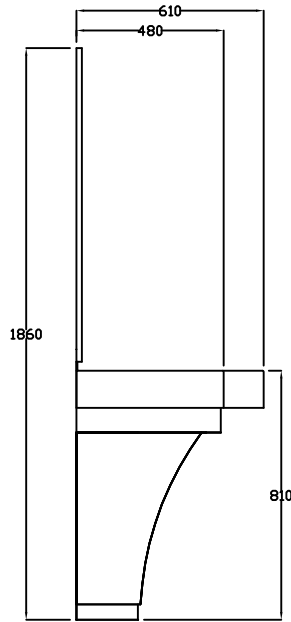

05251 - Duke Link Unit

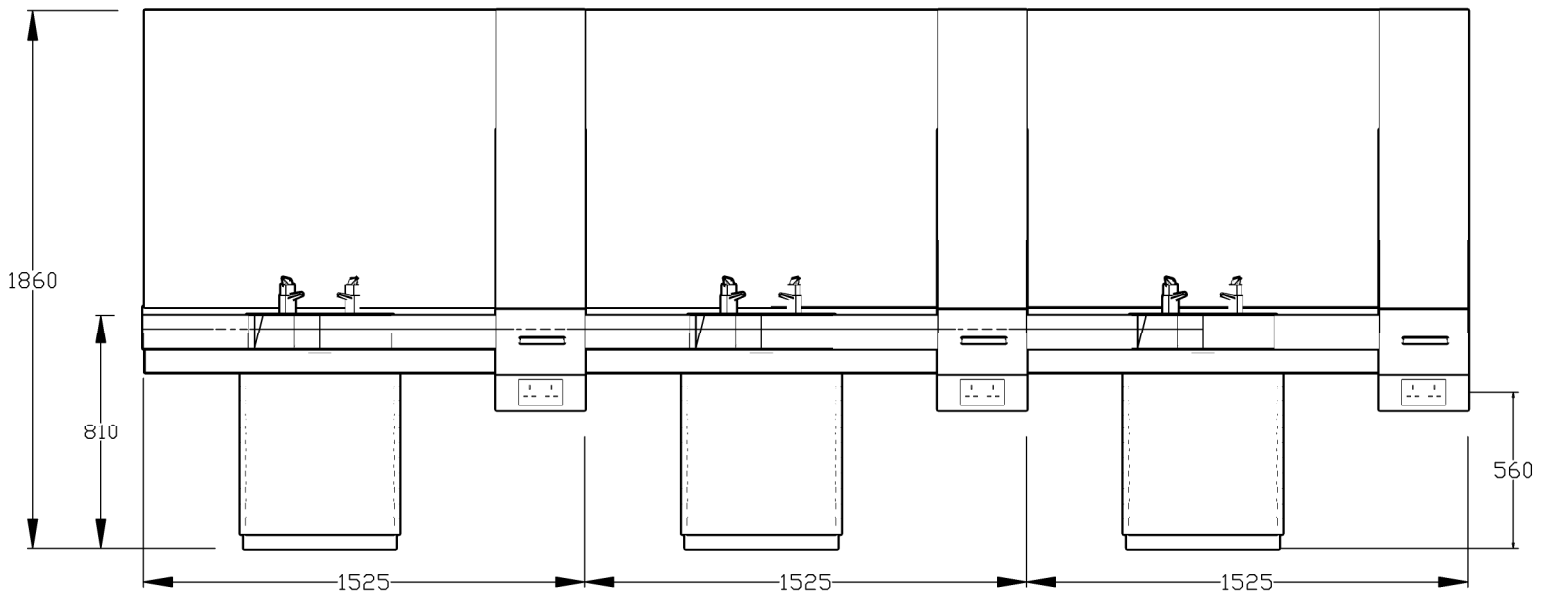
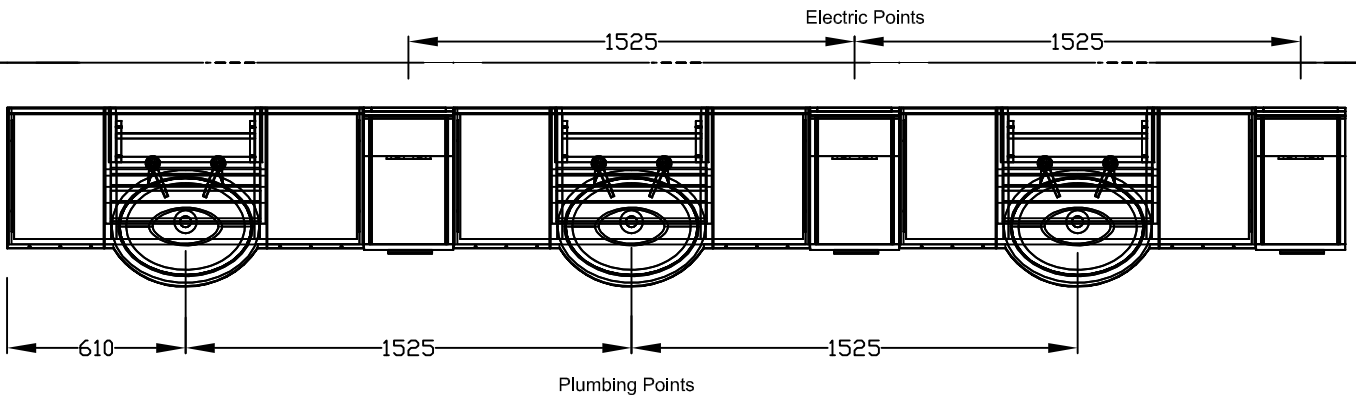

NOTE: these are recommended fitting instructions. Please discuss our recommendations with a qualified furniture fitter.

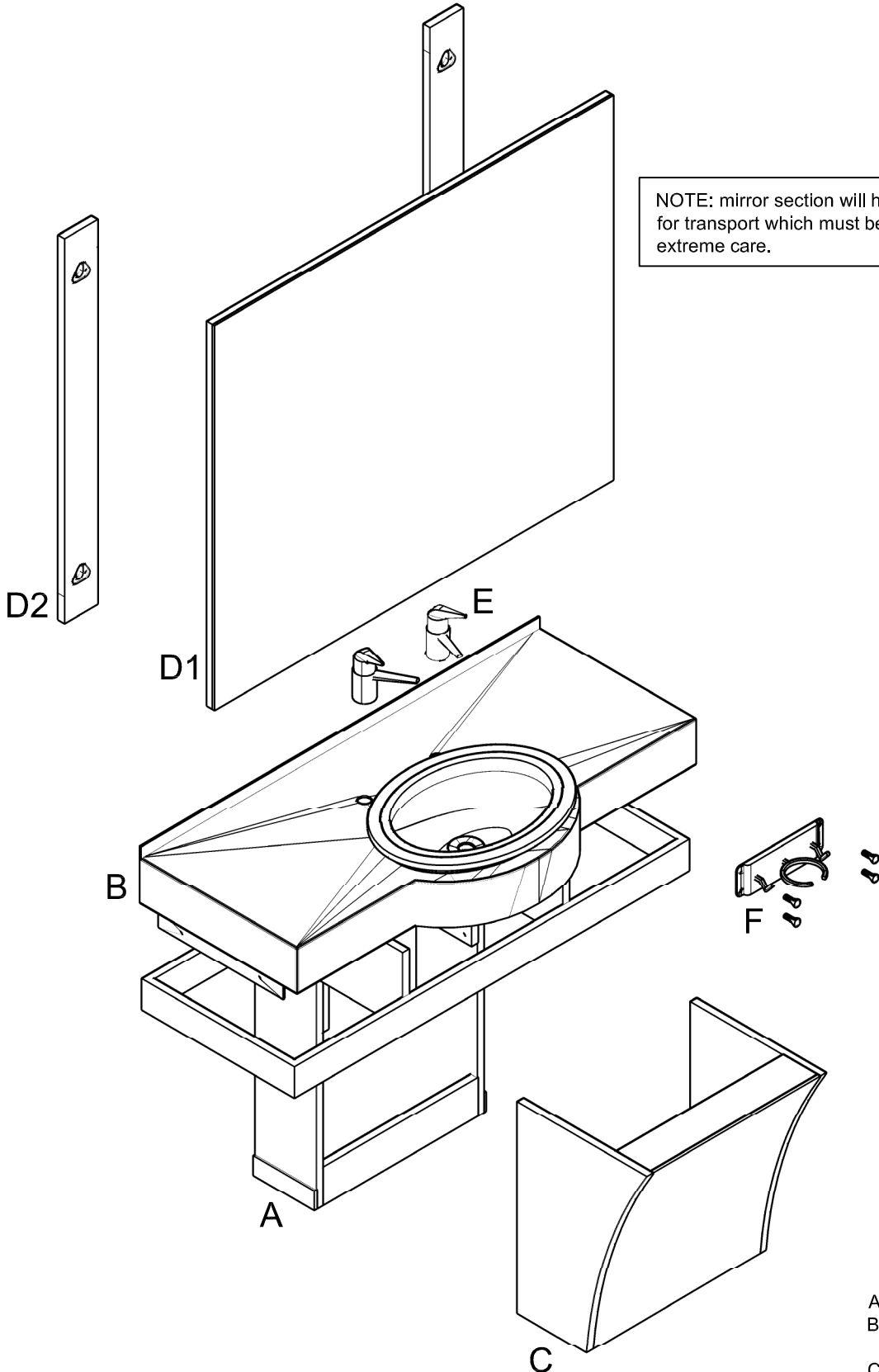

NOTE: mirror section will have timber braces for transport which must be removed with extreme care.

- A : Base Structure
- B : Stainless Steel Top  
+ 12 x wood screw
- C : Front Cover
- D1 : Mirror
- D2 : Backboard x 2
- E : Basin & Tap Kit (if ordered)
- F : Utilities Plate & Fixings (if ordered)

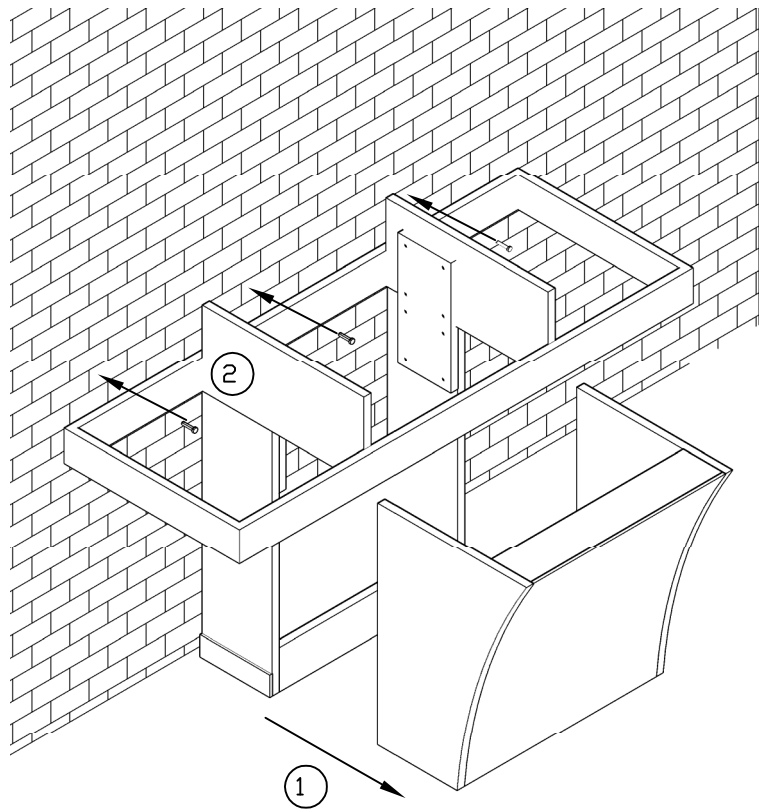

1. Un-screw and remove front cover (C) from base structure (A). Position the base structure (A) in the desired location. Fix into wall at 3 positions shown (2). (no fixings provided - wall dependent)

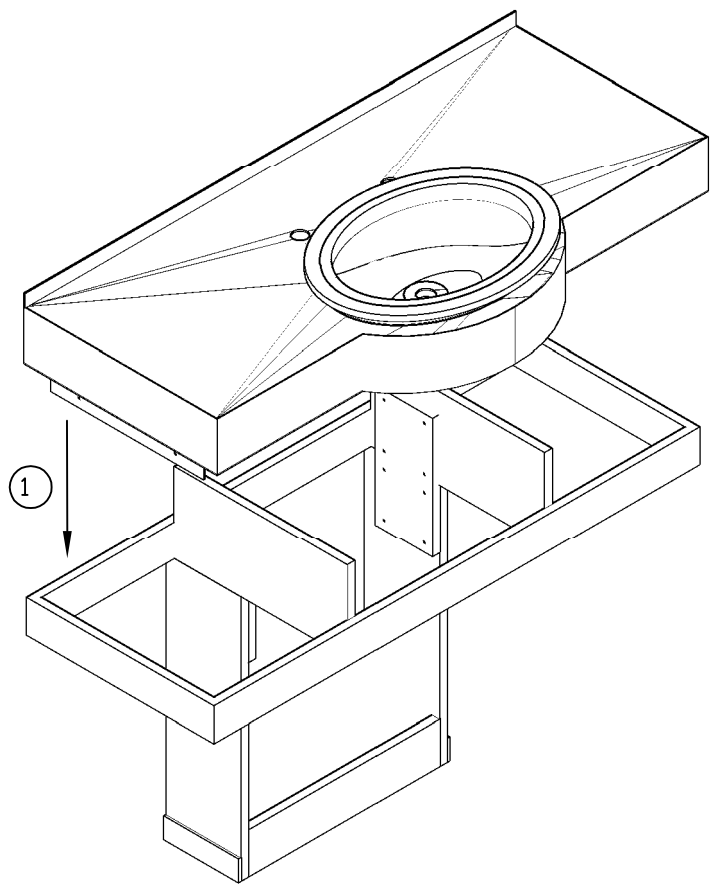

2. Step 1 - Carefully place stainless top (B) over base structure (A)

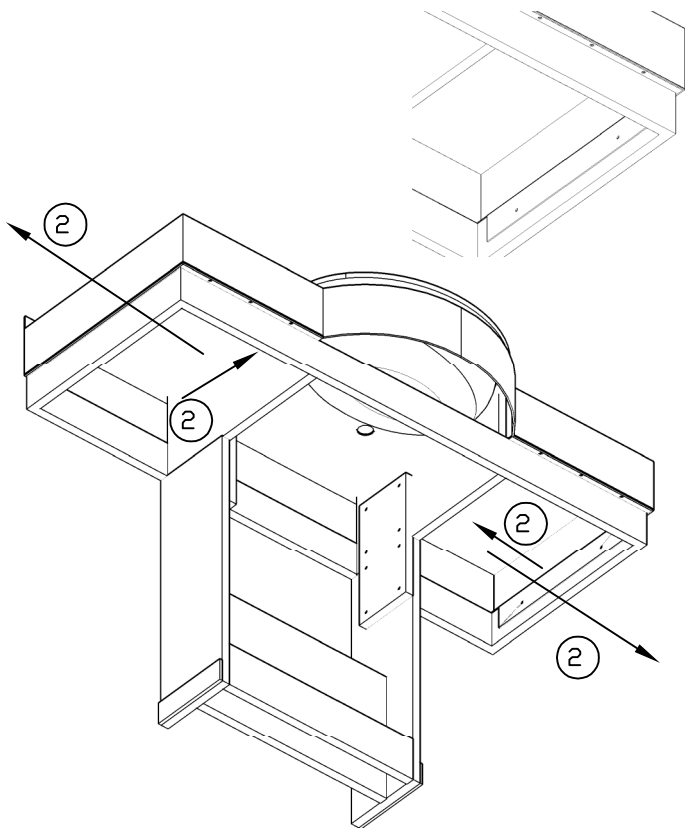

3. Fix into place under unit with 12 wood screws provided as shown in image on right (note some fixing points are behind the front face).

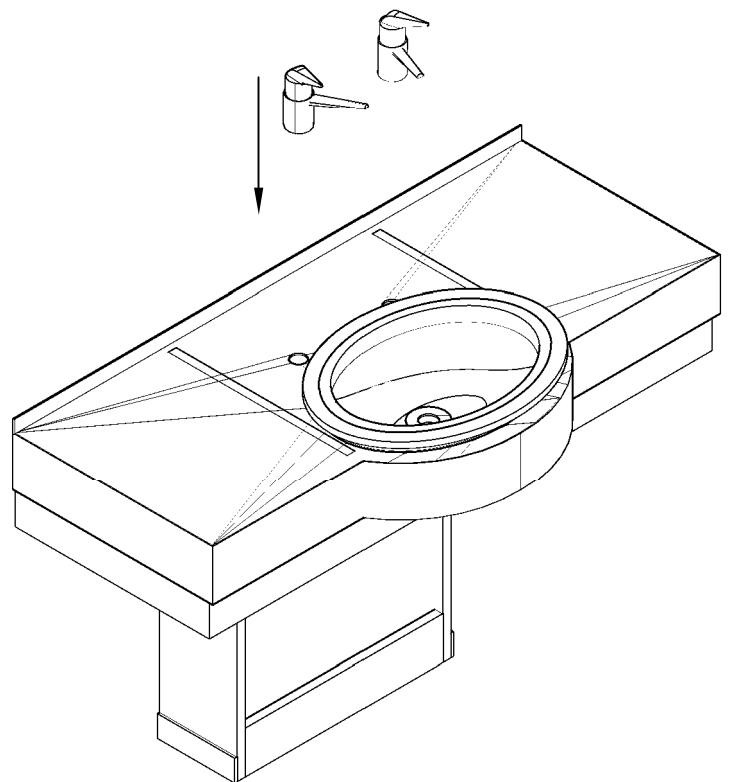

4. See separate installation sheet for taps.

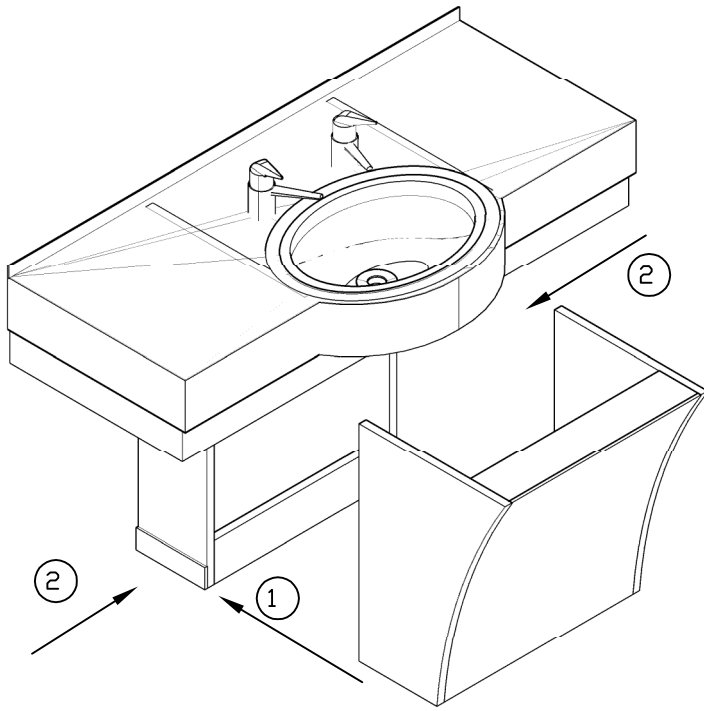

5. Slide front cover (C) over base structure (A) Fix back into position with fixings from stage 1.

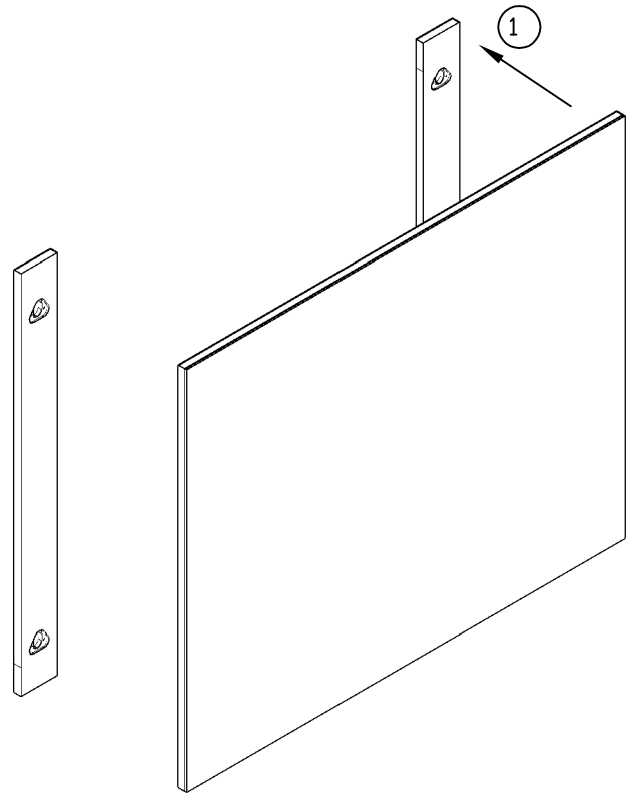

6. Caution should be taken due to size & weight: Carefully remove Backboards (D2) from rear of Mirror Section (D1).

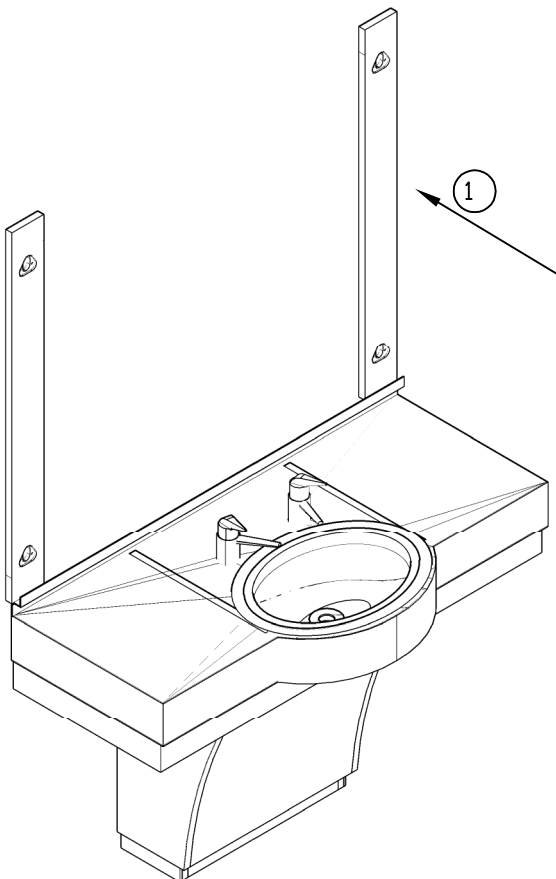

7. 2 person stage:  
Fix Backboards (D2) to wall (no wall fixings provided).  
**WARNING:** Ensure counter sunk fixings are used - No fixings are provided due to variations of wall types (NOTE: base of mirror should not touch top work surface and should be mounted above rear lip)

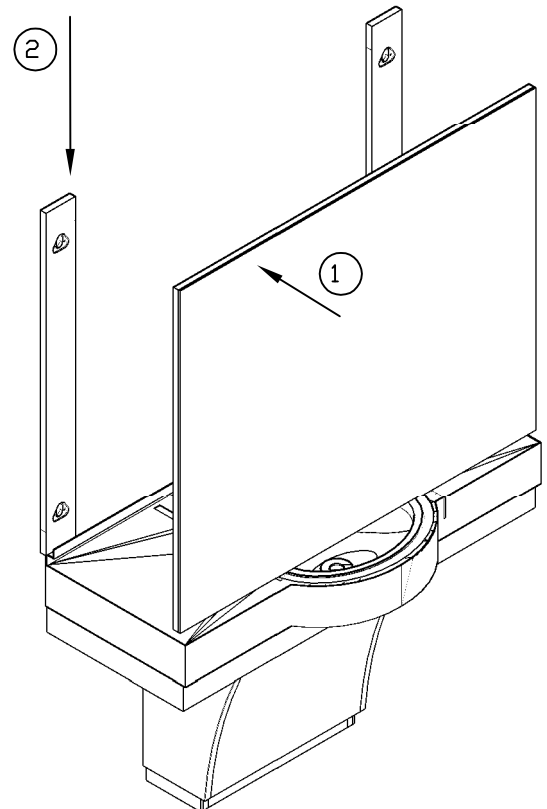

8. 2 person stage:  
Carefully place Mirror (D1) against Back Boards (D2)  
Ease down until the wall unit locks into position and is secure.  
Unit complete.

NOTE: tops of units to be level.

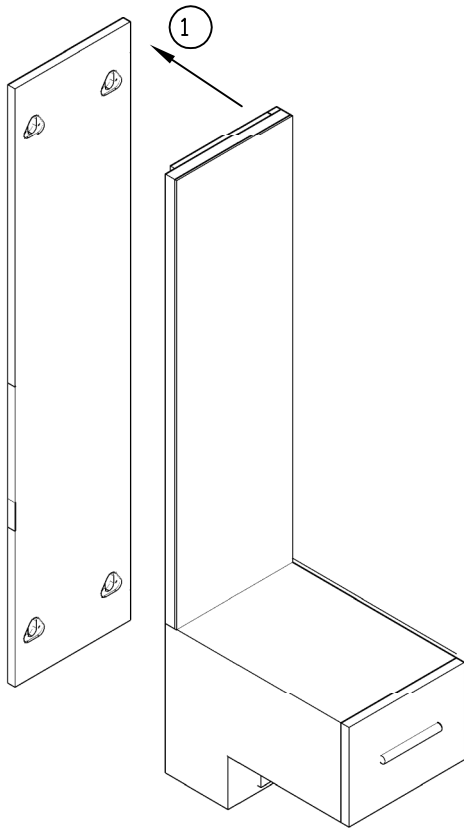

Recommended 2 person required for fitting link:  
1. Caution should be taken due to size & weight:  
Carefully remove Backboard from rear of Link Unit (1).

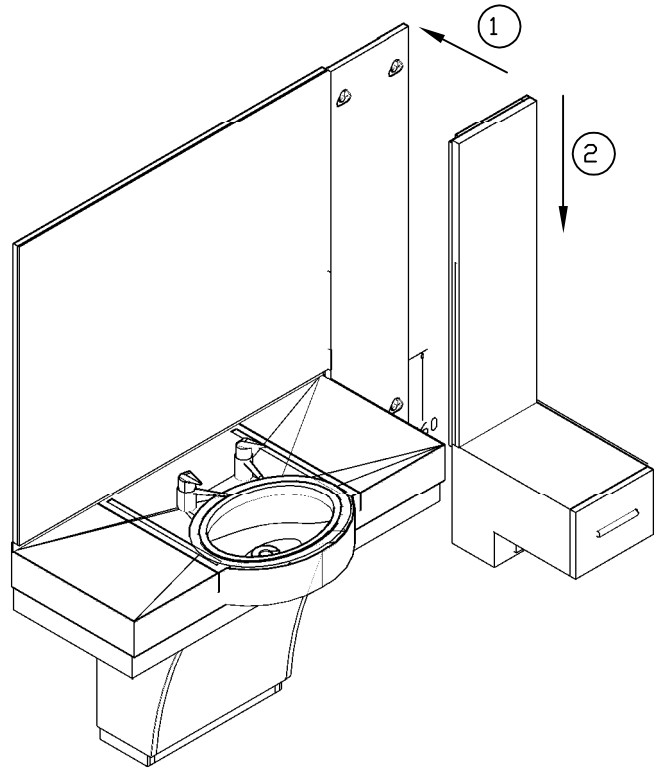

2. 2 person stage:  
Fix Backboard to wall (no wall fixings provided).

**WARNING: Ensure counter sunk fixings are used - No fixings are provided due to variations of wall types (1).**

Carefully place Link Unit against Backboard. Ease down until the wall unit locks into position and is secure (2).

Unit complete.

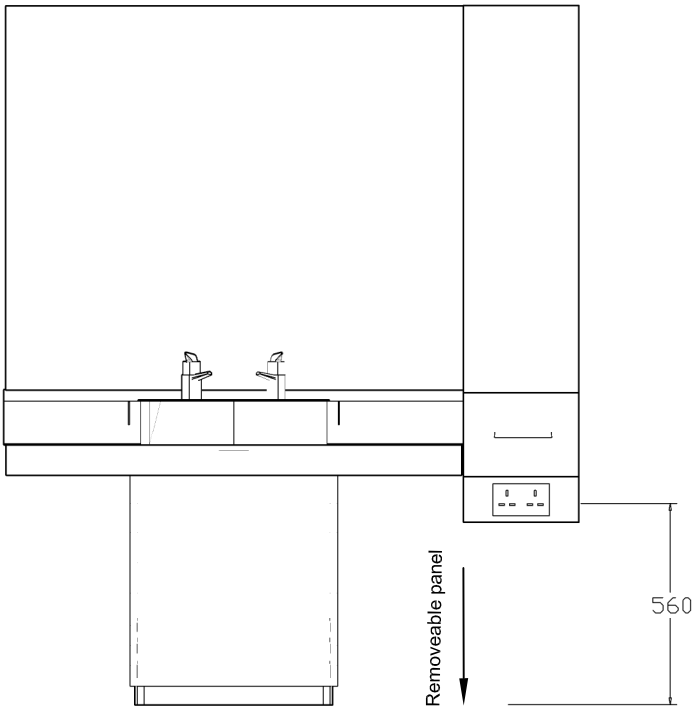

3. Link unit has 60mm diameter hole 560mm from floor for power cables. Plastic panel needs to be removed to gain access. Any electrical sockets to be connected by qualified personnel only.

UNIT COMPLETE.

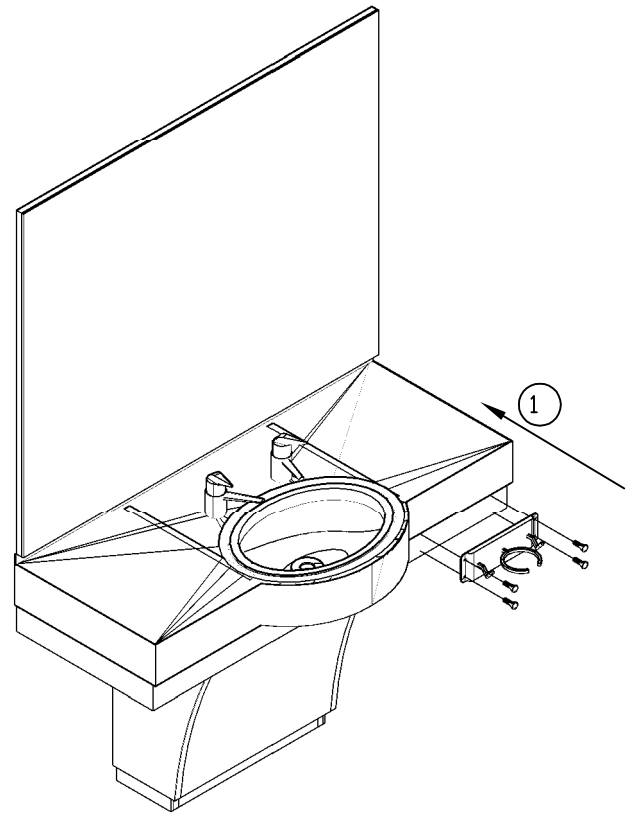
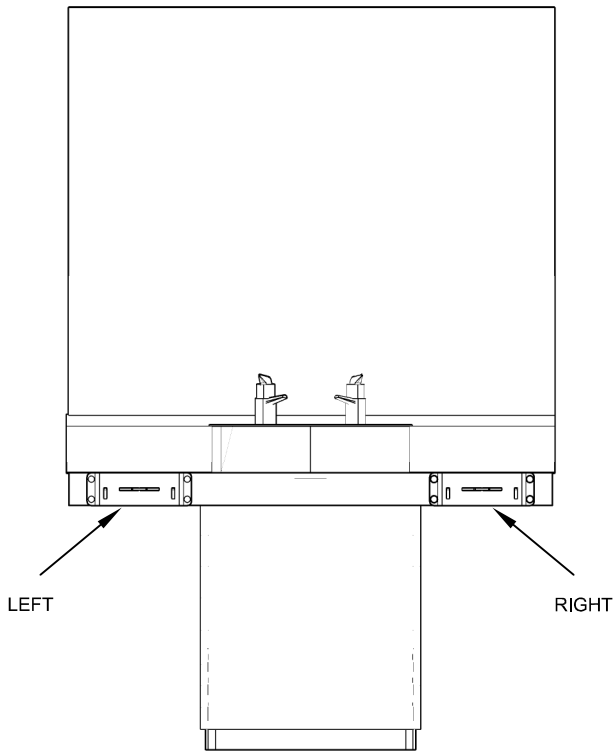

1. Utilities plate can be fixed to left or right of unit.  
Line up holster plate on timber section under front metal lip in required position. Carefully mark through 4 fixing positions and drill pilot holes through timber.  
NOTE: ensure unit is not damaged when drilling holes.

2. Screw holster plate to unit using fixings provided.

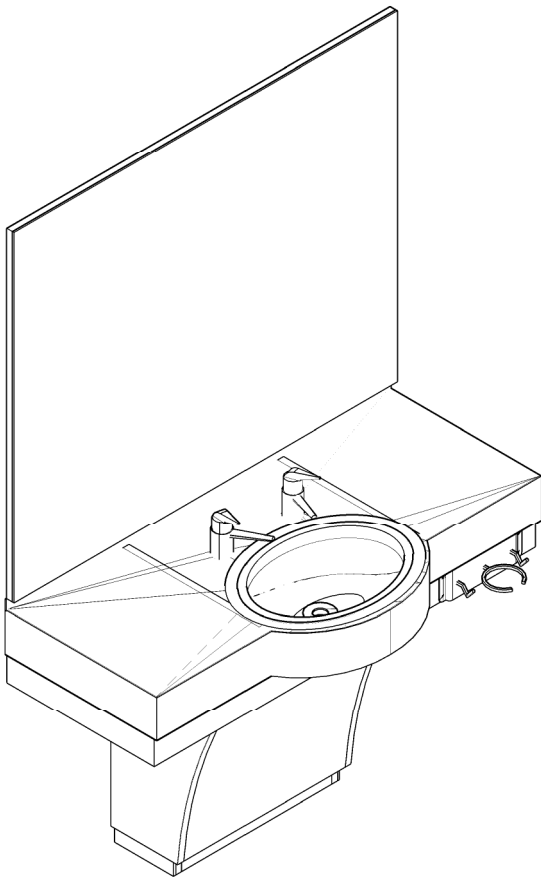

3. Holster complete

A package of component parts may be found to contain:

- A Mixer Valve
- B Black Rubber 'O' (sealing) Ring
- C Half-Moon Washer
- D Brass Rod (slotted one end for fitting purposes)
- E Brass Lock Nut
- F Hand-Spray Hose (female fittings)
- G Hand-Spray (male fittings)
- H Black Sleeve
- I Chrome Collar
- J White Rubber Washer
- K Black Lock Nut

### IMPORTANT NOTICE

Salon owners should be advised to engage the services of a qualified plumber when installing wash points, not least, to ensure that there is adequate mains water pressure available, particularly where 2 or more units are in operation.

Occasionally, in low water pressure areas, a pump may be required. As a guide the water pressure should be between 1.75 - 2.5 BAR equal pressure per outlet.

- i) When fitting Mixer Valve, ensure Black Rubber 'O' Ring is correctly seated in groove in underside of Valve body. A small application of Silicone (or similar) may be required, as a supplement to the sealing ring, between the Valve body and the Basin.
- ii) The Half-Moon Washer should be fitted with the ridged surface facing downward.
- iii) Fit the Brass Rod and Lock-Nut but tighten only after making sure that the Valve Lever is parallel to the rear of the basin (in 'off' position)
- iv) Check both ends of the Hand-Spray Hose to ensure that there is a black rubber washer in place in each one.
- v) Screw Hand-Spray into one end of Hose and feed other through Black Sleeve, Chrome Collar, and Basin. Position White Rubber Washer and Black Lock Nut on Hose before connecting other end to Valve outlet hose.
- vi) Tighten the whole assembly only when Hand-Spray is seated correctly in the sleeve and points over the Basin towards the Waste outlet.

**N.B. Care should be taken here to avoid scoring, or otherwise marking the Basin surface, due to the downward pressure of the Chrome Collar. (Holding the Hand-Spray in the correct position whilst tightening the assembly is the best way to carry out this operation)**

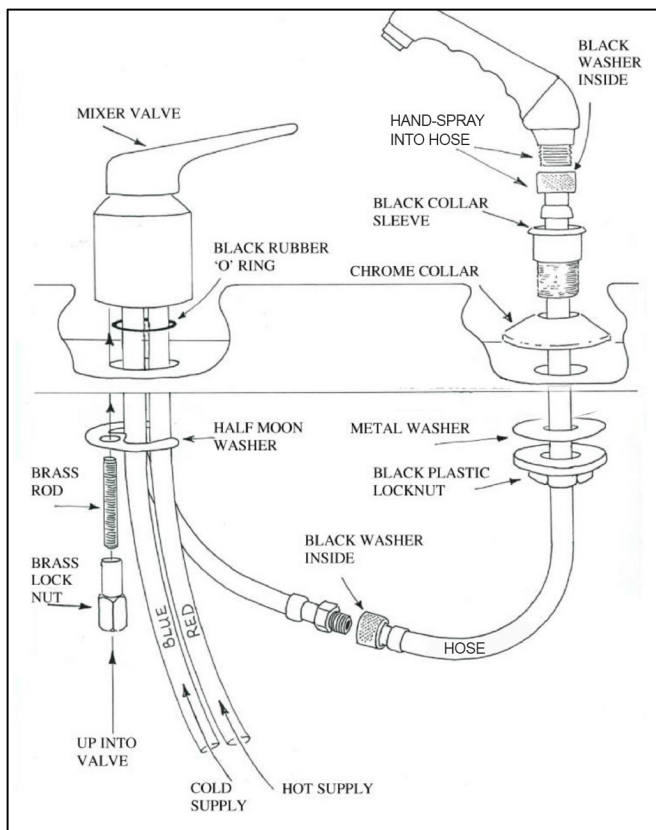

### OTHER NOTES

Ensure adequate Hot & Cold balanced supply to meet requirements of all units being fitted. Minimum 2.5 Bar per outlet Pump(s) may be required in Low Pressure Areas.

Please ensure that the hose and handspray are tightened mechanically, by the use of plumbers grip or similar. REM recommend the use of a sealant tape (such as PTFE tape) between the two components

Avoid use of detergents when cleaning leathercloths. (Soap and water should be adequate).

REM guarantee all Units against manufacturing fault only, for a period of twelve months.

The terms of this guarantee do not affect your Statutory Rights.



**Fabrics:**  
DECLARATION OF CONFORMITY OF CERTAIN FIRE RETARDANCY STANDARDS.

BS 7176 is the British Standard which specifies the requirements for the resistance to ignition of upholstered furniture manufactured for seating or similar usage, but excluding use on domestic furniture or transport seating. Tests have been carried out on all REM products and fabrics in accordance to BS EN 1021-1: 2006 and BS EN 1021-2: 2006 which satisfy the performance requirements of Low Hazard Category of BS 7176 (resistance to ignition sources: Smouldering Cigarette and Match Flame Equivalent).

Typical examples of furniture that are required to meet the Low Hazard Category are Schools, Colleges, Offices, and Day Centres.

All of the cloths the REM swatch are available on the majority of REM products and meet the Medium Hazard Category (Public Buildings, Restaurants, Hotel Bedrooms, Hospitals etc) of BS 7176 which is similar to the above but also includes the Ignition Source 5 test of BS 5852: 2006.

It should be noted also, that whilst the test levels for the various hazard categories are set after careful consideration of the particular end-user environments involved, they are not intended to reflect the behaviour of the upholstery in a fully developed fire. A label is available for use on items produced in accordance with this standard, although there is no legal requirement to attach said label. These can be supplied on request at the time of ordering (printed to suit Low and Medium Hazard Only).

All products are subject to availability. REM reserves the right, without further notice, to alter the material specification of our products, if necessary to provide the highest levels of product quality.

**Laminate:**  
Each laminate shown in the REM swatch has been carefully selected from the Polyrey, Wilsonart & Egger Quality Collections of high pressure laminates (HPL). They can all be postformed (with the exception of Alu Brosse), and are suitable for commercial use. Please note that Matt Black has a tendency to fine scratching and finger marks when applied to horizontal working surfaces.

REM has made every effort to ensure that the Laminates presented in our swatch book are as the original. All products are subject to availability. REM reserves the right, without further notice, to alter the material specification of our products, if necessary to provide the highest levels of product quality.

Please ensure that you discuss any queries with our technical staff. For more colour ideas visit [www.rem.co.uk](http://www.rem.co.uk).

**NOTE**  
REM declines all responsibility for any injury to persons or damage to property caused by installation or assembly that has not been carried out in compliance with the general warnings, and the installation instructions of the pole/base and/or wall arm. REM declines all responsibility for any injury to persons or damage to property caused by installation or assembly carried out by non-qualified persons. REM declines all responsibility for injury or damage resulting from the unsuitability of the wall for the wall hood processor and arm only.

**Environmental Protection**



The crossed-out wheeled bin symbol which you will find on the Rating Plate attached to your product, or appearing in the Assembly / Operating Instructions, signifies an obligation by you as purchaser or owner, to dispose of the equipment in accordance with the European Directive 2002/96/EC. This is a statutory instrument commonly known as the 'WEEE Regulations', which effectively requires you to carry out disposals of all Electrical and Electronic Equipment separately from your usual waste facilities. Specialist waste controls, designated by the Government (or Local Authorities) are to be made available to prevent potentially harmful substances affecting the environment and causing a possible human/animal health risk.

More detailed information is available from your local Environmental Health Office, Local Authority Waste Disposal Service, or the sales point from which the product was originally purchased.

REM's Producer Registration Number is **WEE/BJ0066TW**

**Guarantee**

**What this Warranty Covers**

This warranty covers any product defects arising from faulty materials or workmanship; or defects arising from direct delivery transport damage. It is important to note that damages must be reported within 72 hours and are only covered for the address on the REM delivery note. Any issues relating to incorrect specification or missing components must be reported within 28 days from delivery.

**What this Warranty Does Not Cover**

Any problems arising from damage caused by misuse, failure to install correctly, damage caused during 3rd party transportation and storage, or fair wear and tear. (Goods delivered by the wholesaler or courier arranged by the wholesaler or end user will be classed as 3rd party transportation.)

**What is the period of this Warranty?**

This Warranty extends for a period of three years from date of purchase. Customers must retain their receipt from the supplying REM Distributor as proof of purchase. Any wholesaler stock items will be covered for three years, where applicable, from date of purchase from the wholesaler but exclude transport damage.

**What we will do to correct problems**

REM will, at its discretion, repair or replace defective products. During the first year of ownership for UK Mainland customers only, REM will supply and, at its discretions, fit replacement parts or products. In years 2 and 3 for UK Mainland customers and for years 1, 2 and 3 for all customers outside UK Mainland, REM will supply replacement parts or products at its cost.

**What we will not do**

REM will not be responsible for any associated costs of refitting or reinstalling any products which have been replaced nor will it be responsible for any costs incurred arising from the non-availability of its products awaiting repair or replacement.

**How do you get service?**

Should any problems arise with your REM product please use the REM Support Link which is found at <http://www.remsupport.co.uk/>.

**How does this affect my statutory rights?**

This three year warranty in no way affects your statutory rights and is intended as an additional safeguard and benefit for buying and using REM products.

**Notable Exceptions to the warranty**

1. Miranda Dryer is covered by 12 month warranty only.
2. Rio Mag Lamp is covered by 12 month warranty only.
3. Apollo, Apollo Lux, Studio, Jupiter, Nero, Penta and Monet Trolleys are covered by 12 month warranty only.
4. Any repairs carried out by REM personnel or accredited REM engineers have a 3 month guarantee.

**Other Exceptions to the warranty**

1. Upholstered seats are covered by a 3 year warranty except for where cloth gathers or stretches under use.
2. Dryer Pole Wing Nuts are considered a wearable part and not covered by warranty.
3. Hoses for REM washpoints are considered a wearable part and not covered by warranty.
4. Handsets for REM electric couches are only covered by warranty for the first 12 months.
5. Stained Upholstery due to hair dye and other products are not covered by warranty.
6. Stained Upholstery due to denim or similar are not covered by warranty.
7. Stained work surfaces due to nail varnish and similar products are not covered by warranty.
8. Damaged glass components or mirrors are not covered under warranty unless the damage was occurred during delivery and reported within 72 hours.
9. Visors on REM Hood Dryer are covered by warranty for transit damage only.
10. Any items damaged in transit are only covered by warranty if delivered on REM vehicles or REM appointed subcontractors. Any items collected from REM by customers or where collection has been arranged by customers are not covered for any transit damage.
11. Any items purchased from REM Reconditioned stock, invoiced on a code beginning with 3045 are not covered by warranty.
12. Any items purchased from Ebay or similar are not covered by warranty.

**REM Returns Policy**

- All defects arising from faulty materials or poor workmanship; or defects arising from transport damage will be returned to REM at no cost to the customer.
- Where REM agree to replace a product, the replacement item will be charged to the customer's account. The returned unit will be credited in full once it has been received back at REM. In cases where the reported fault cannot be found, no credit will be authorised.
- Unwanted goods, or items not meeting customer requirements; which are free from the defects listed above, un-used, and in its original packaging will be considered for credit by a duly appointed representative of REM. A minimum charge of £60 will apply and will be communicated before the returns order is processed.
- Items manufactured to the specific requirements of the customer (such as made-to-order furniture and upholstery; and bespoke furniture) are non-returnable. If the item is faulty it will be replaced or repaired at REM's cost, as per our terms and conditions.
- REM will attempt collection of an arranged return a maximum of two times at which point the customer/wholesaler will have to arrange their own transportation for the goods to be sent back to REM or the returns note will be cancelled and any charges on the note will be applied to the account.