

BACKYARD OFFSET SMOKER OPERATION MANUAL

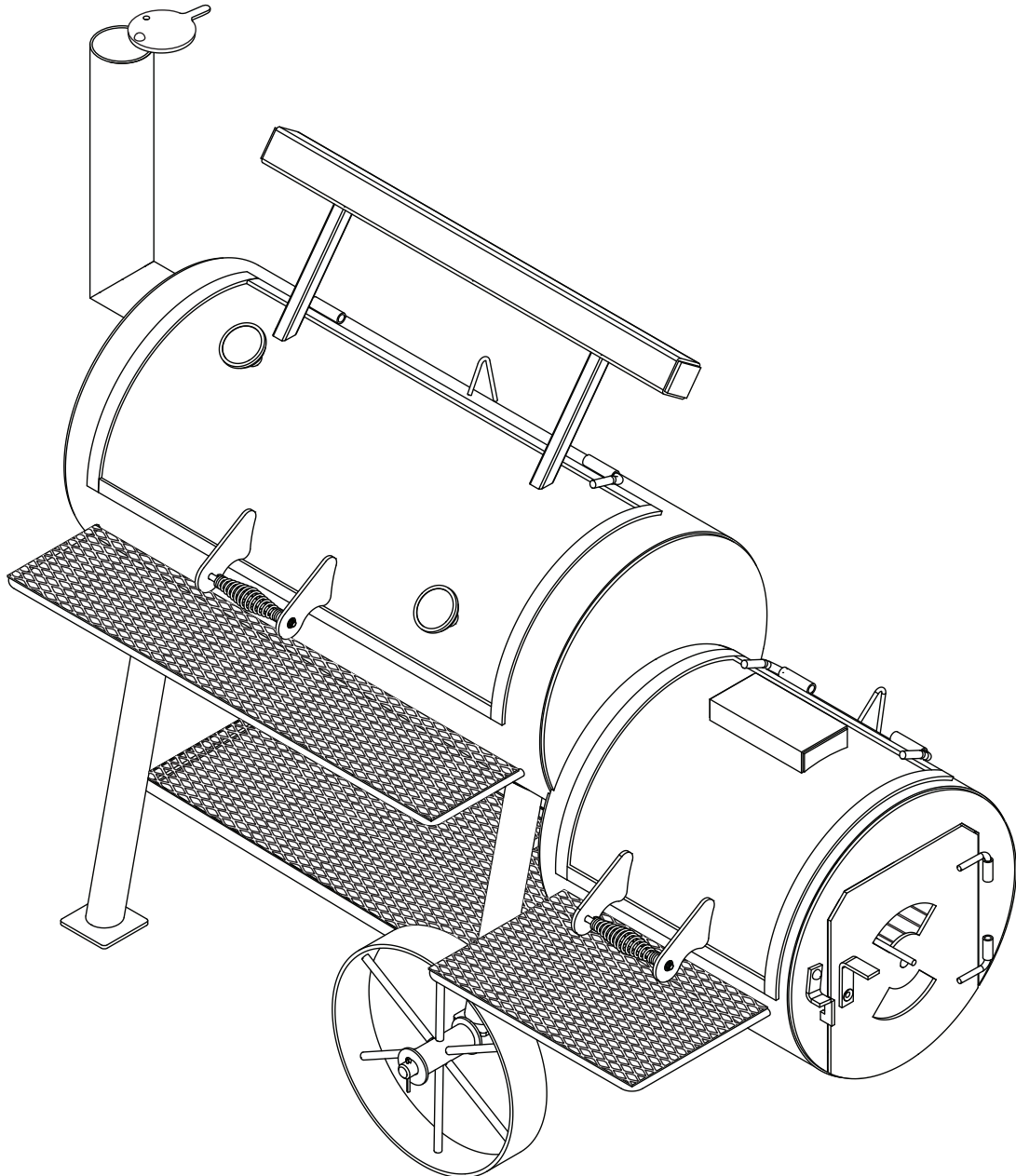

Welcome to Yoder Smokers

Thank you for purchasing a Yoder Smoker. You are joining a family of satisfied customers. We are very proud of our product and that it is handcrafted in the heartland. Please review the following information carefully. It will give you great tips and information that will help you use your Yoder.

Please complete the form below for future reference. Additionally, complete the online Warranty Registration (www.yodersmokers.com/warranty-registration-form) using the information that you filled out below. If you would rather mail in your warranty information there is a form on the back of the manual that you can fill out and send in. Your serial number is located on the metal plate on your smoker's door.

Thank You for Choosing Yoder Smokers

Model _____

Serial Number _____

Date of Purchase _____

Purchased From _____

Contents

Dangers, Warnings and Cautions.....	3
Available Product Add-Ons.....	4
Smoker Diagram.....	6
Smoker Assembly.....	7
• Smoker Arrival.....	7
• Installing the Thermometer.....	7
• Re-Installing the Butterfly Damper.....	8
• Smoker Placement.....	9
• Leveling the Smoker.....	9
Operating the Smoker.....	10
• Initial Burn Off.....	10
• Lighting Your Smoker.....	10
• Pre-Heating.....	10
• Door Position.....	10
Pre-Grill Checklist/Routine Maintenance.....	11
How to Build a Fire For Your Smoker.....	12
How to Use Your Smoker for Direct Grilling.....	14
• Using the Firebox for Direct Grilling.....	14
• Using the Cooking Chamber for Direct Grilling.....	15
Grill Maintenance.....	18
• Preparing the Grill For Season.....	18
• Painted Surfaces.....	18
• Cooking Grates.....	18
• Heat Management Plate.....	18
• Cooking Chamber.....	18
• Grease Management and Bucket.....	18
• Additional Maintenance.....	19
• Storing Your Grill.....	19
Wood Flavor Guidelines.....	20
Wood Usage.....	20
How Often Do I Maintain My Fire.....	20
Meat Temperature Guide.....	21
Warranty Information.....	22

Dangers, Warnings and Cautions



Failure to follow the “Dangers, Warnings and Cautions” contained in this manual may result in serious bodily injury, death or in a fire.

- **Read this manual completely before using your Yoder for the first time.**
- Do not use indoors! This smoker is for outdoor use only.
- Do not leave pets, infants, or children unattended near a smoker in use.
- Keep the grill a **minimum** of 12 inches away from combustible surfaces.
- Do not use lighter fluid, gasoline, or any other highly flammable fluids to ignite or re-ignite your smoker.
- Do not use or store lighter fluid, gasoline or any other highly flammable fluids within five feet of the smoker.
- Do not transport your grill while operating or when the grill is hot. Make sure the fire is out and the grill is cool before moving.
- Exterior surfaces on the grill will be **hot** when in use and during cool down.
- Should a grease fire occur, keep the door closed until the fire is out.
- Use heat resistant gloves when operating the grill.
- Do not remove any ash until the fire has completely burned out and are fully extinguished.
- Check the Yoder website (www.YoderSmokers.com) occasionally for updates and new product information for the Yoder.

Available Product Add-Ons

2nd Level Slide-Out Shelf

Adding the second shelf increases the cooking area in your smoker.

Log Lighter

The log lighter allows you to use propane to get the fire started.

Charcoal Grate

Adding a charcoal grate to your smoker allows you to convert the main cooking chamber into a direct grill.

Heat Management Plate

The heat management plate installs against the common wall of the firebox and the cooking chamber. The design forces the heat and smoke to enter the cooking chamber under the heat plate and is then released incrementally as it travels across the cooking chamber. This design reduces the side to side temperature variance that is commonly seen in offset cookers.

Counter Weight

The counter weight is welded onto the door of the main cooking chamber. The counter weight assists in opening the door by reducing the weight that is being lifted.

Pot Warmer

The pot warmer is a metal channel welded onto the top of the firebox door. The heat from the firebox warms the channel and you can place a pot on it to keep it warm.

For more information about any extra accessories, call your local Yoder dealer or contact us directly at 877-409-6337 or email us at service@yodersmokers.com.

Smoker Name	Part Number
Cheyenne	
Log Lighter	W41695
Charcoal Grate	41440
Heat Management Plate	41433
Wichita	
Log Lighter	W41695
Charcoal Grate	41440
2nd Level Slide-Out Shelf	W41788
Heat Management Plate	41212

Smoker (cont)**Part Number (cont)****Loaded Wichita**

Log Lighter
Charcoal Grate

W41695
41440

The Kingman

Log Lighter
Charcoal Grate

W41695
42587

Durango 20"

Log Lighter
Charcoal Grate
2nd Level Slide-Out Shelf

W41695
41440
W41788

Durango 24"

Log Lighter
Charcoal Grate

W41695
42587

The Stockton

Log Lighter

W41695

Smoker Diagram

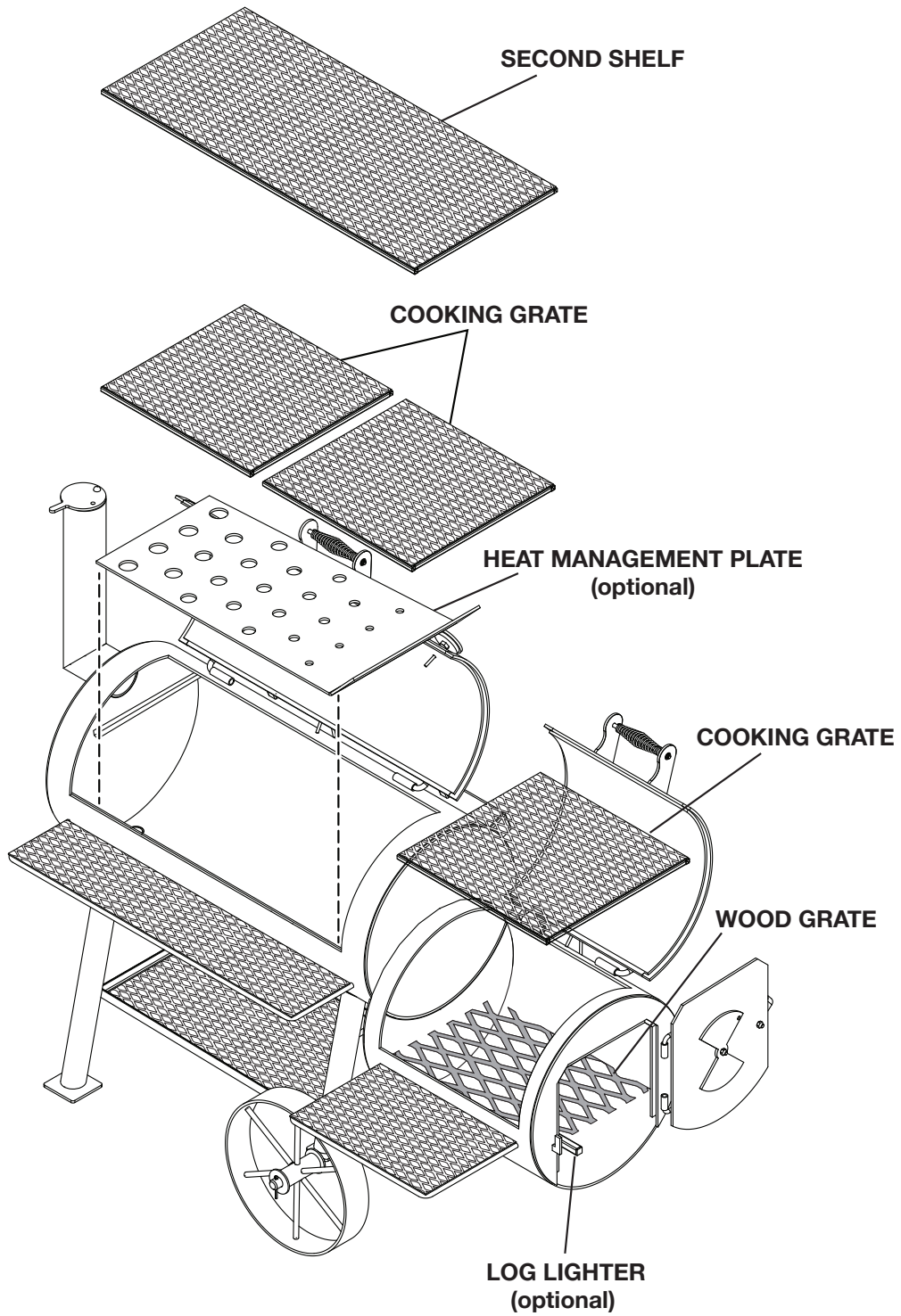

NOTE: Loaded Wichita shown. Your smoker may vary slightly depending on model.

Smoker Assembly

Smoker Arrival

Your Yoder Smoker will arrive on a pallet wrapped and held on with banding. Cut the bands and remove the plastic wrap and foam from the smoker. Remove the smoker from the pallet. It is recommended that two people remove the Yoder from the pallet due to its size and weight. Open the cooking chamber and remove the two cooking grates and ash rake. If your cooker is ordered with options, you will find them packaged inside.

Before the initial use of your Yoder Smoker, two simple installations are necessary:

Installation I: Install Thermostat/Temp Gauge, as follows:

1. Open smoking chamber and take out the box containing the thermometer.
2. Remove thermometer from box. Notice that the gauge has a gauge housing, threaded barrel section with jamb nut, and thermostat end.

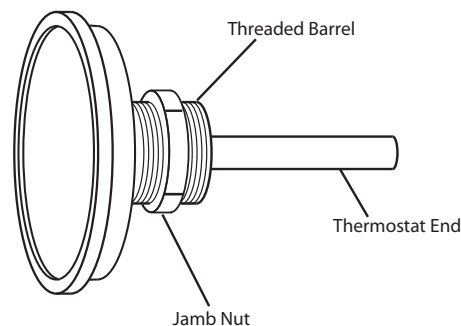

3. Locate the mounting port for the thermometer in the cooking chamber door. It is threaded internally in order to secure the thermometer.
4. Insert the thermometer, probe end first, into the mounting port, then thread the thermometer at least 6 turns into the port.
5. Rotate the thermometer face for proper orientation, then tighten down the jamb nut against the mouth of the mounting port to prevent the gauge from turning.

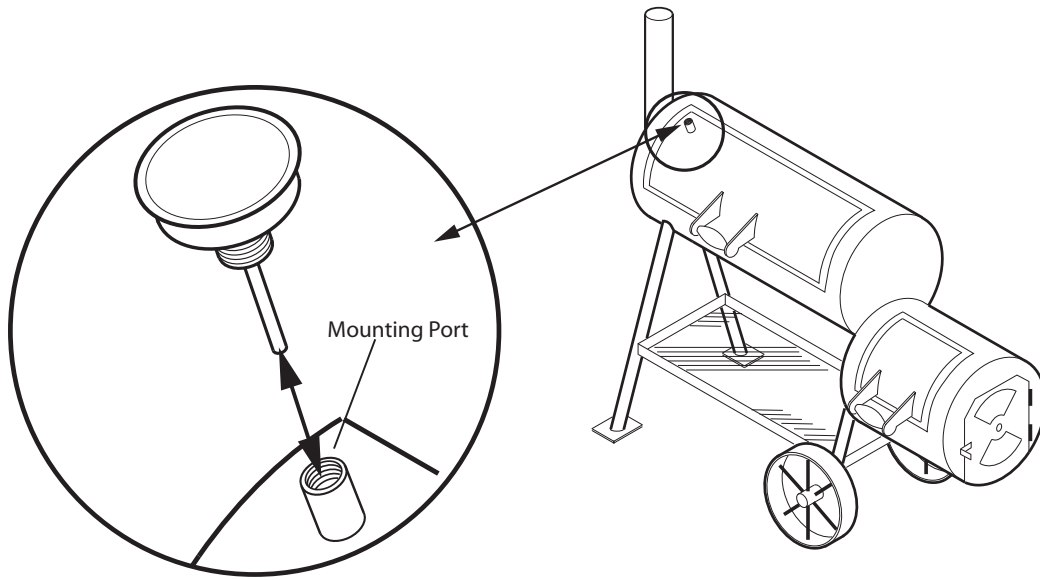

Before the initial use of your Yoder Smoker (Continued):

Installation II: Re- Install Butterfly Damper as follows:

1. Your Yoder Smoker is shipped with the butterfly damper installed inverted (this done to avoid damage to the damper handle in shipment).
2. To install the damper to it's correct position, simply open the firebox door and unthread the nut and bolt securing the center of the butterfly damper.

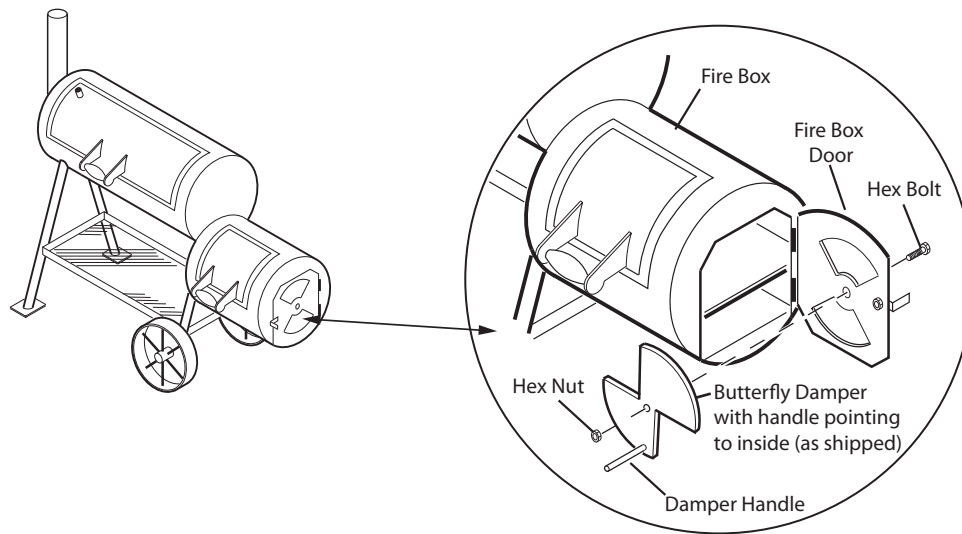

3. Rotate butterfly 180° so that handle is pointing to outside of firebox door.

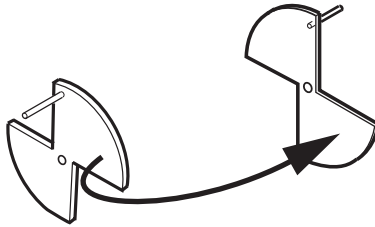

4. With butterfly damper rotated, reinstall on fire box door using hex bolt and hex nut.

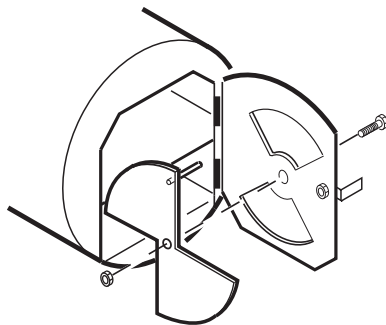

Re-install butterfly

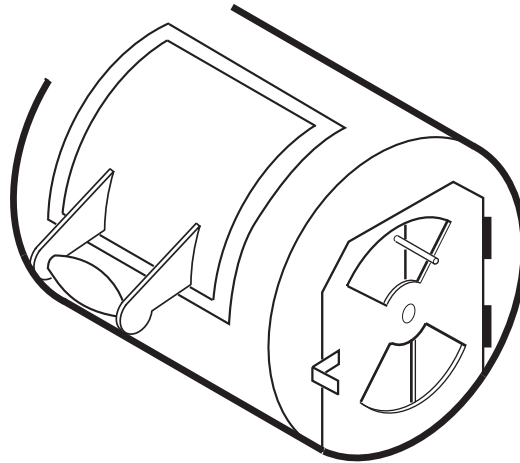

Re-installed butterfly with handle pointing to outside.

Smoker Placement

All Yoder smokers/grills should always be a minimum of 12 inches away from any combustible surface (wall, rail, etc.).

Leveling the Smoker

To level the smoker, stand in front of the cooking chamber door and place a level on the lower shelf to help you level the smoker. You need to level the smoker from front to back and not side to side. Leveling the smoker from side to side will offset the slope that is built in to the smoker and could cause the grease to run towards the firebox.

Operating the Smoker

Initial Burn Off

Before cooking on your smoker for the first time, burn off the grill to rid it of any foreign matter. Operate the grill at 275°F to 350°F with all options and grates in place with the door closed for two hours.

Lighting Your Smoker

Always go through the Pre-Grill Checklist (Page 8).

Look at section “How to build a fire” for tips on creating a fire for your smoker.

Pre-Heating When Used As A Smoker

Pre-heating your Yoder is important. Allow 45 minutes to get a coal bed built and for the steel in the pit to heat up. Once the desired cooking temperature is reached, the pit will be ready to cook on.

Door Position

Preheat and cooker with the door closed. This allows for faster heat-up and will keep the cooking temperature even; the food will cook faster while consuming less fuel.

Pre-Grill Checklist/Routine Maintenance

Perform the following services when the grill is cool

1. Open the cooking chamber door and remove the cooking grates.

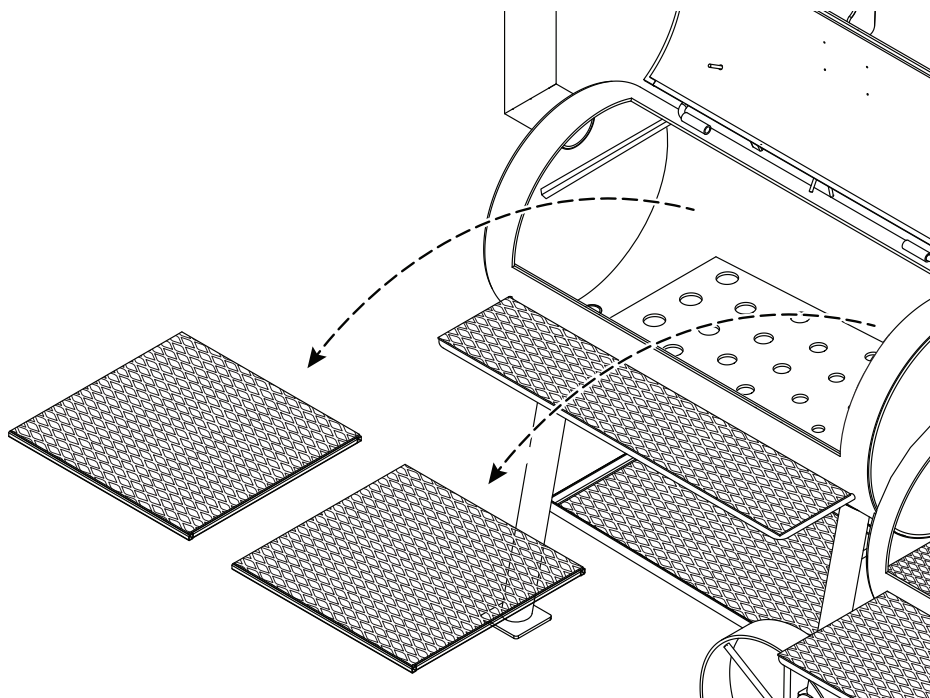

FIG 1

2. Remove the heat management plate if applicable.

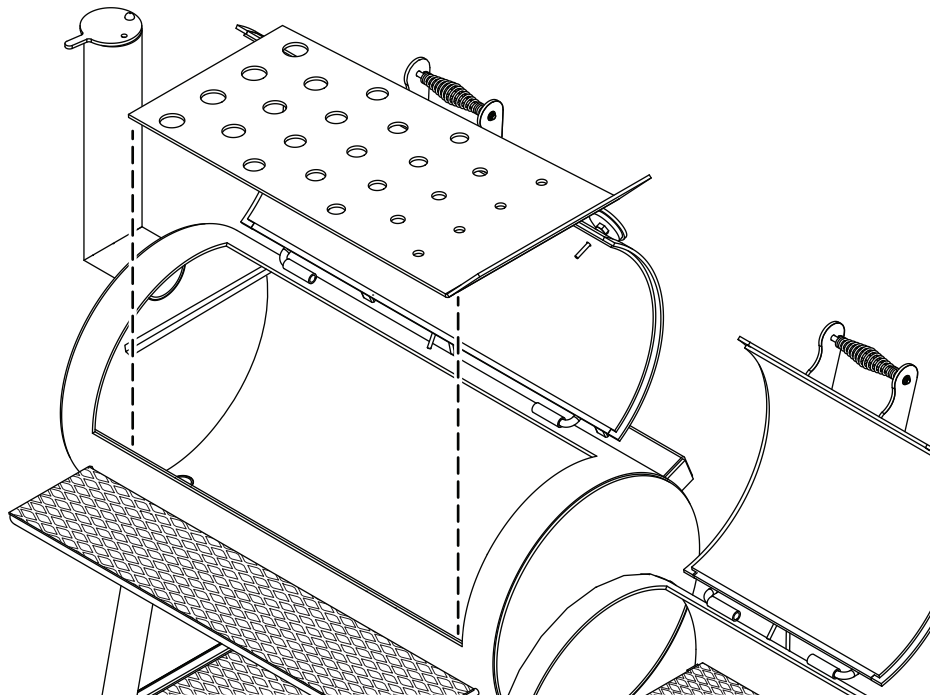

FIG 2

3. Inspect the bottom of the cooking chamber for any grease build up and clean as needed. See page 16 for more details.

4. Install the heat management plate. See **FIG 2**.

5. Install cooking grates and optional second shelf See **FIG 1**.

6. Clean grease bucket as needed. See **FIG 3**.

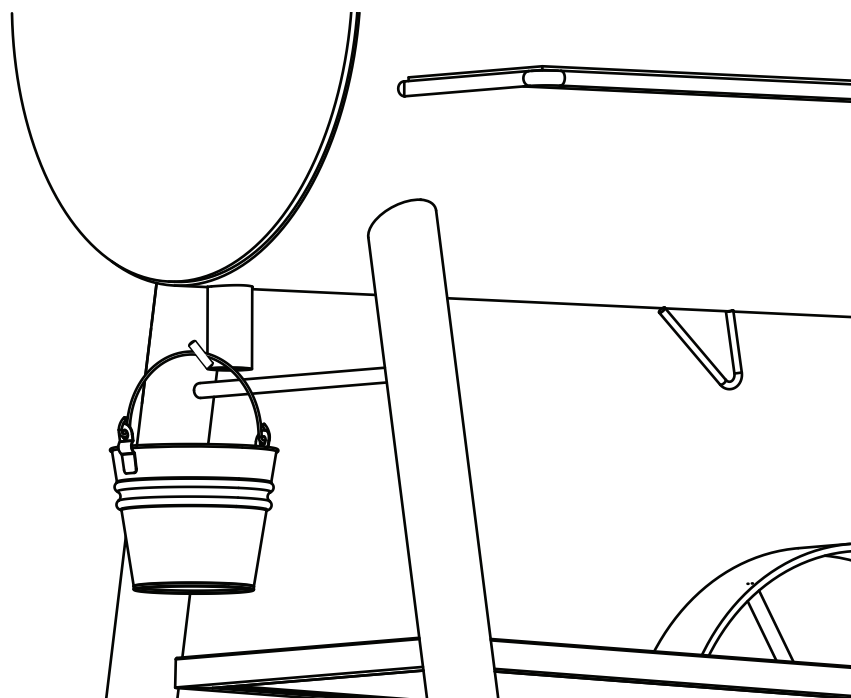

FIG 3

How to Build a Fire for Your Smoker

Start with the firebox door, main damper and chimney damper in the open position. This will increase airflow and speed the fire building process.

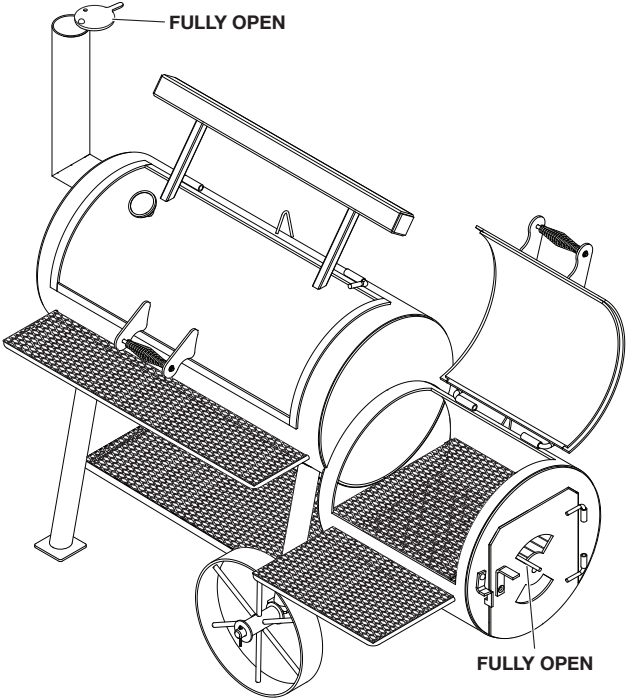

FIG 4

It is preferable to start with a charcoal base. Once you have a hot bed of charcoal, close the door and place two pieces of wood onto the coal base.

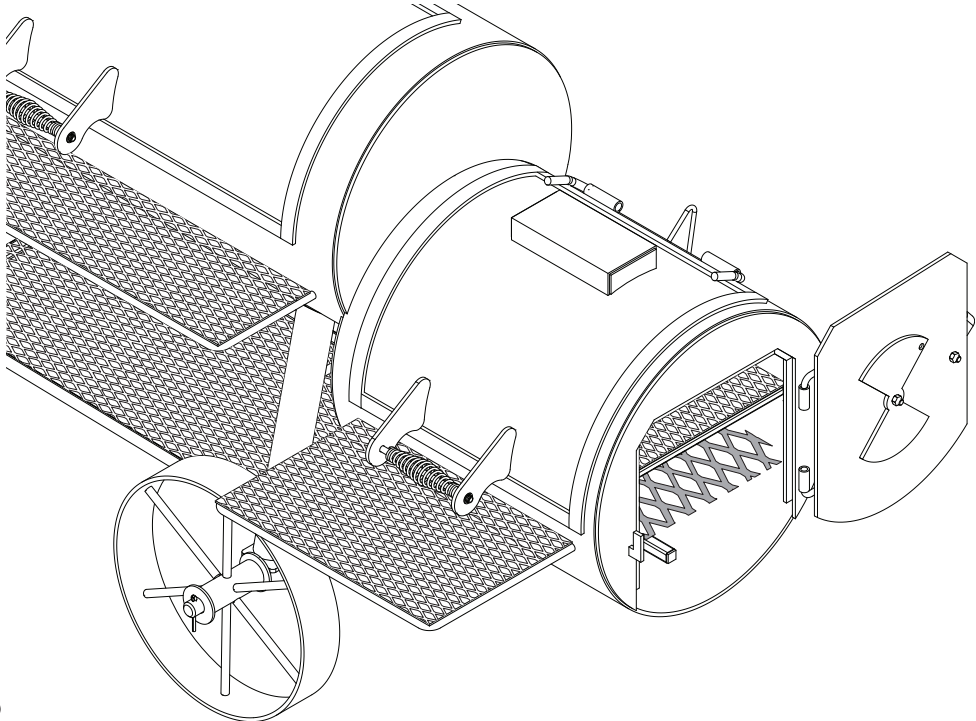

FIG 5

As the wood reduces to coal, close both dampers to the halfway position to allow the pit temperature to begin to rise.

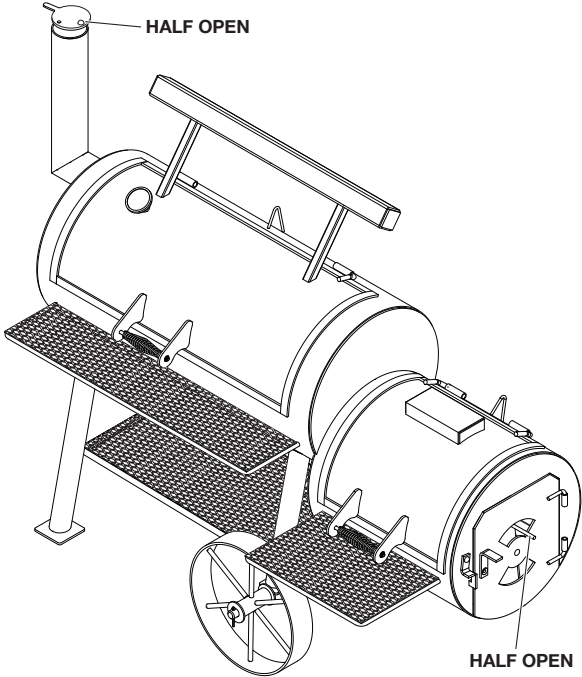

FIG 6

Once the pit stabilizes at the desired temperature, add one piece of flavor wood. You are now ready to cook.

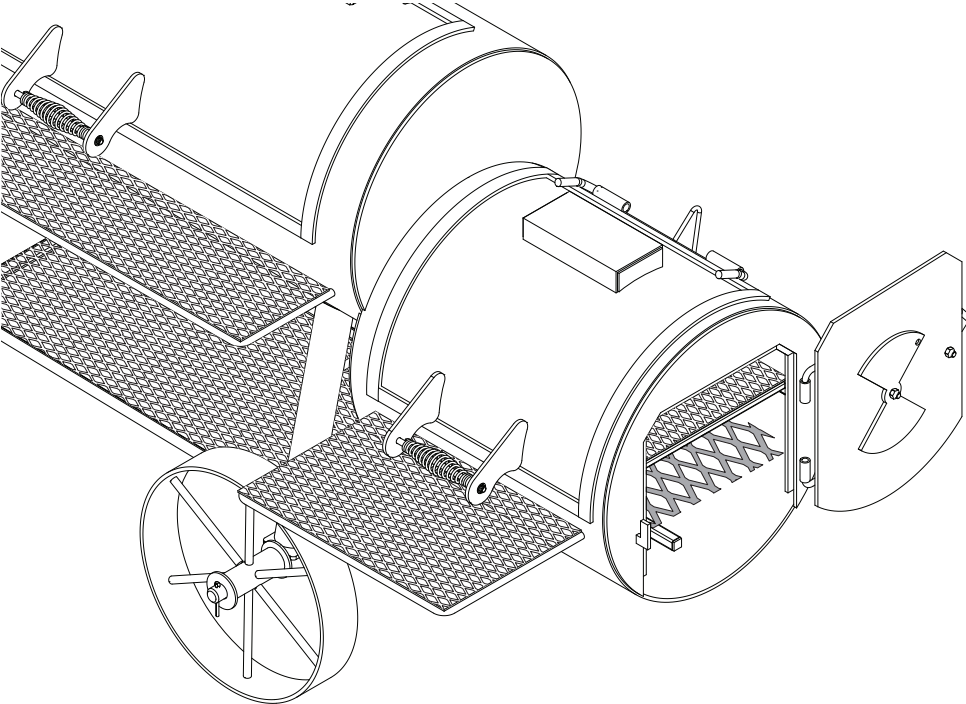

FIG 7

How to Use Your Smoker for Direct Grilling

Using the Firebox for Direct Grilling

Start with the firebox door, main damper and chimney damper in the open position. This will increase airflow and speed up the time it takes for the coals to be ready to cook on.

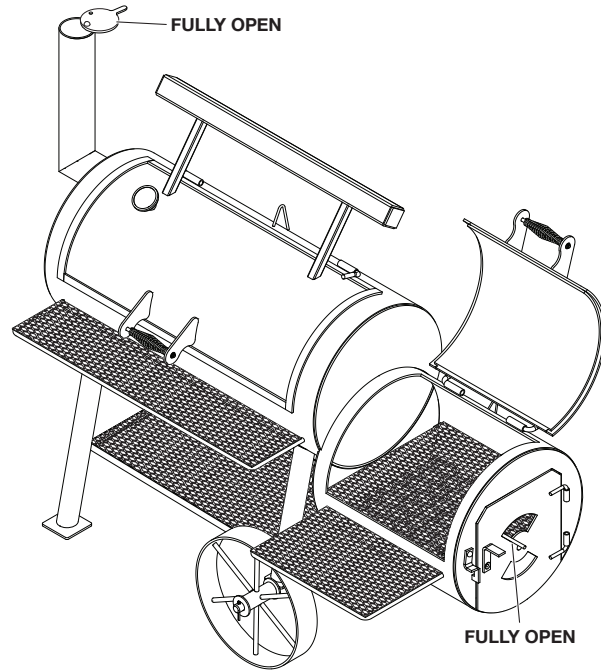

FIG 8

Place your charcoal onto the wood grate and ignite the coals. Once this is done you can close the side door. **NOTE:** We do not recommend using lighter fluid to ignite the charcoal.

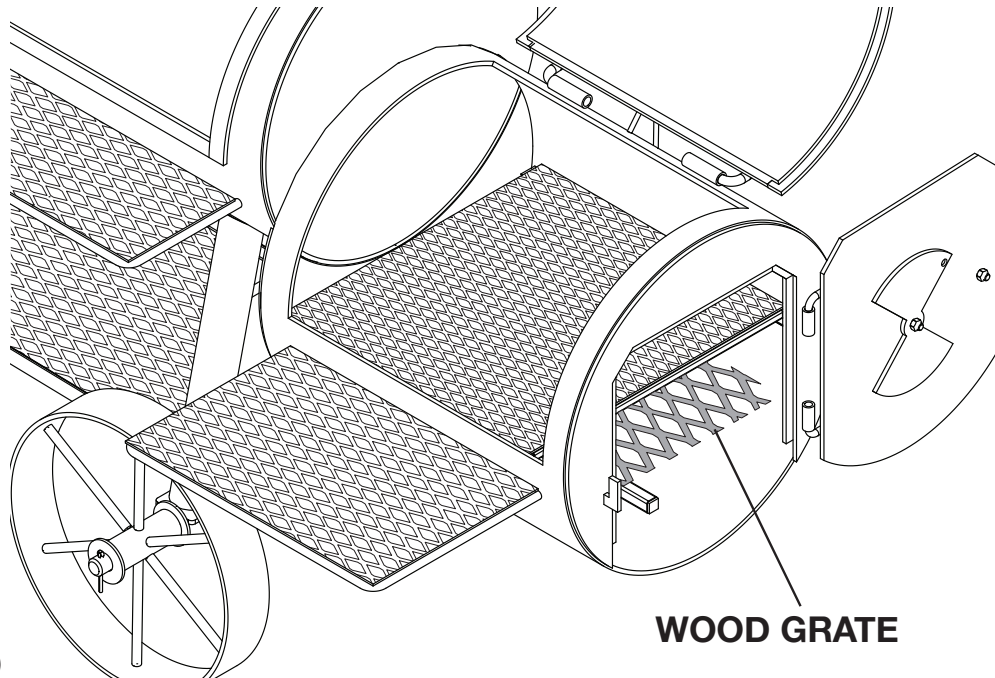

FIG 9

Once you have a hot bed of coals, close the damper to the halfway position. You are now ready to cook.

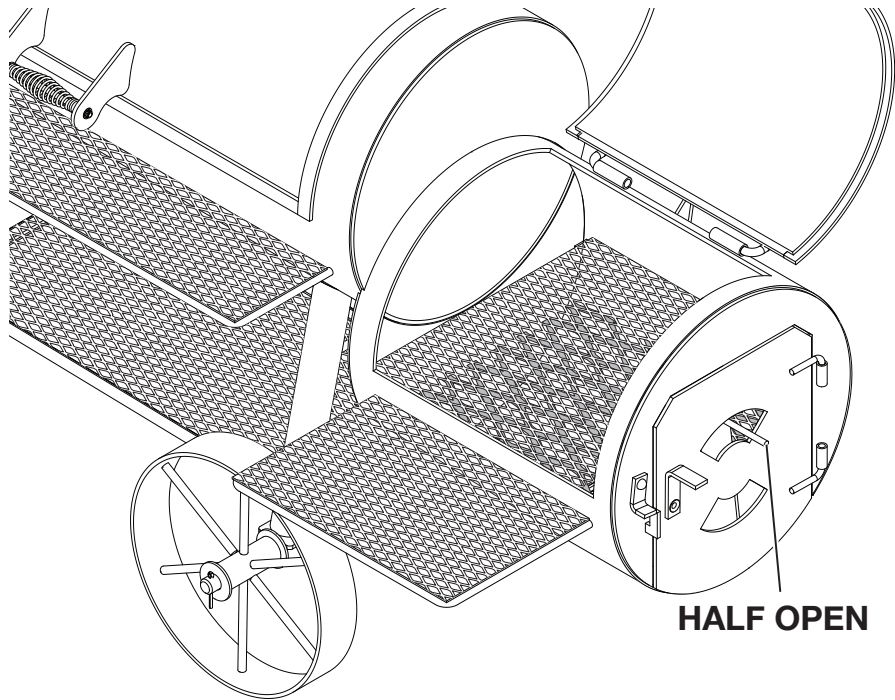

FIG 10

Using the Cooking Chamber for Direct Grilling

This is an optional accessory for your smoker. If you have any questions about it, call us at 1-877-409-6337.

Start by removing the cooking grates and the heat management plate (if applicable).

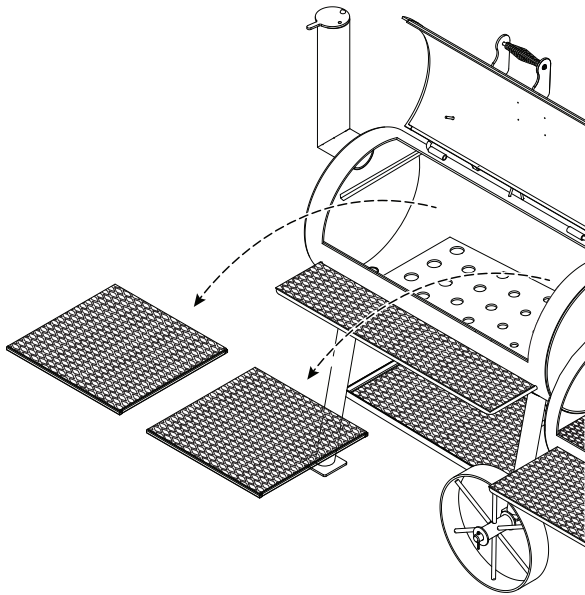

FIG 11

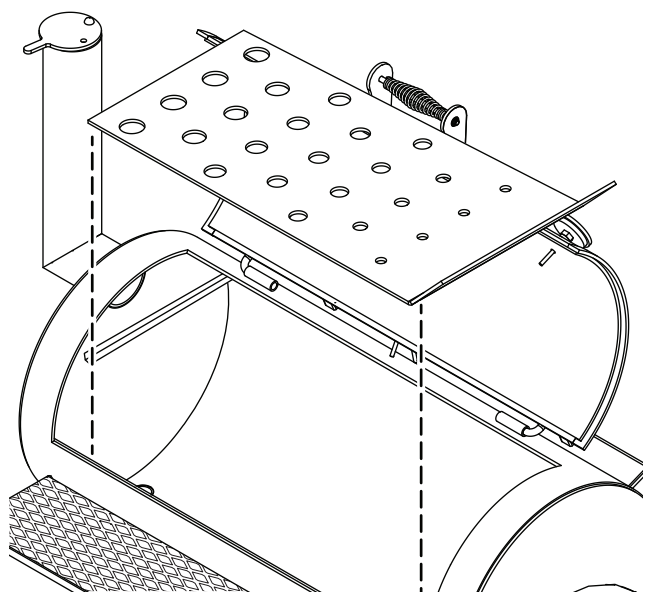

FIG 12

Place the charcoal grate into the cooking chamber. Place your charcoal onto the charcoal grate and ignite the coals. We do not recommend using lighter fluid to ignite the charcoal. **Note:** The charcoal grate sits against the walls of the cooking chamber.

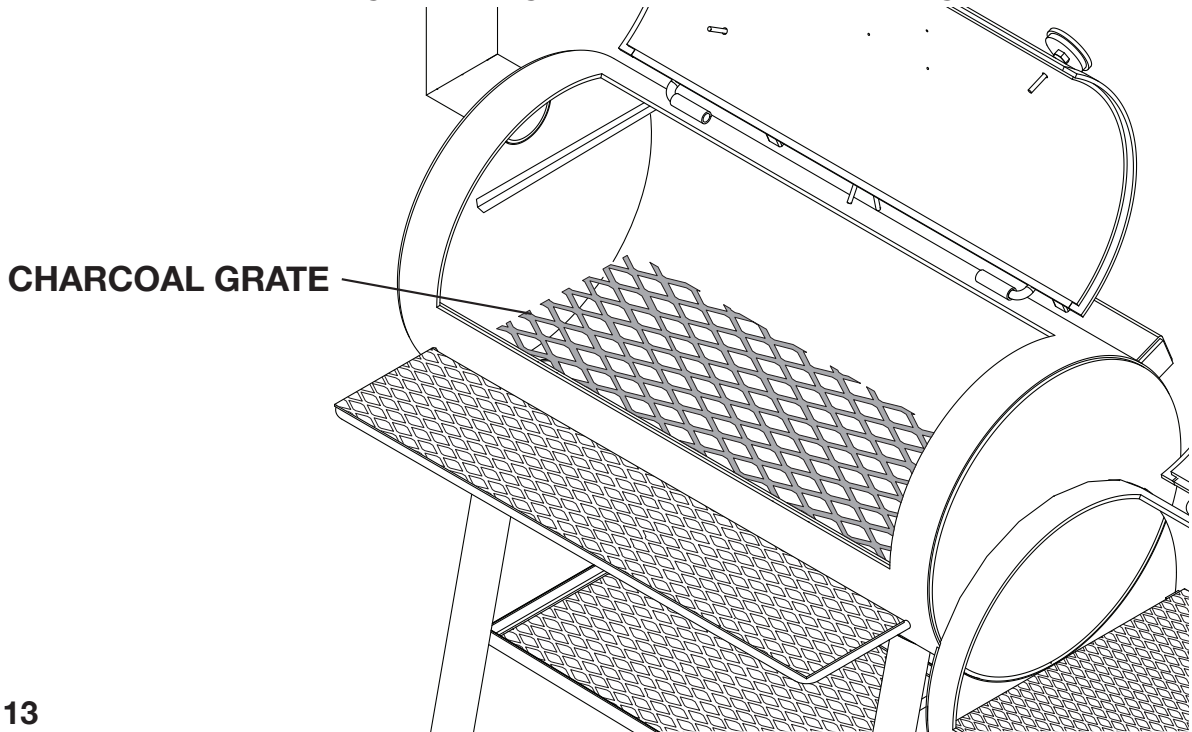

FIG 13

Be sure the main damper, chimney damper and main cooking chamber door are open. This will increase airflow and help get the coals up to cooking temperature.

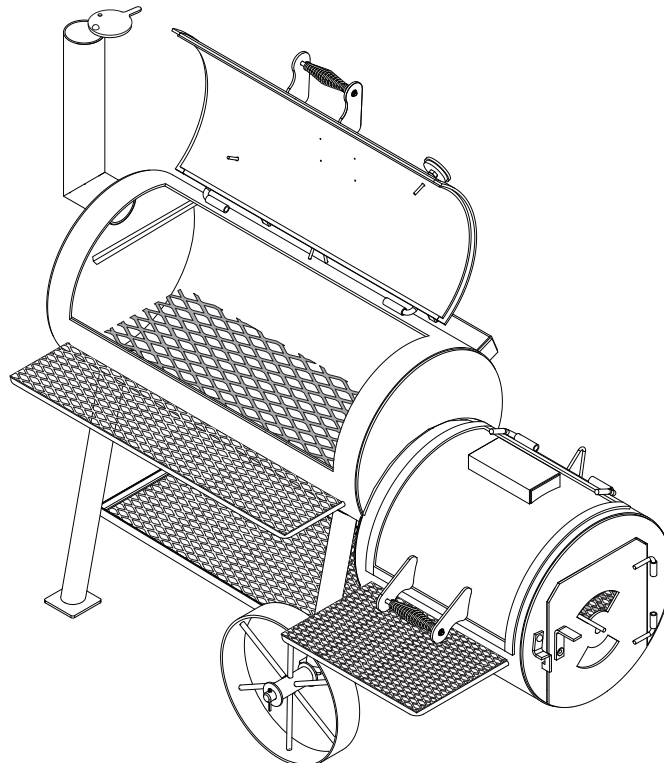

FIG 14

After the coals are started, place cooking grates back into the cooking chamber. Once you have a hot bed of charcoal you are ready to cook.

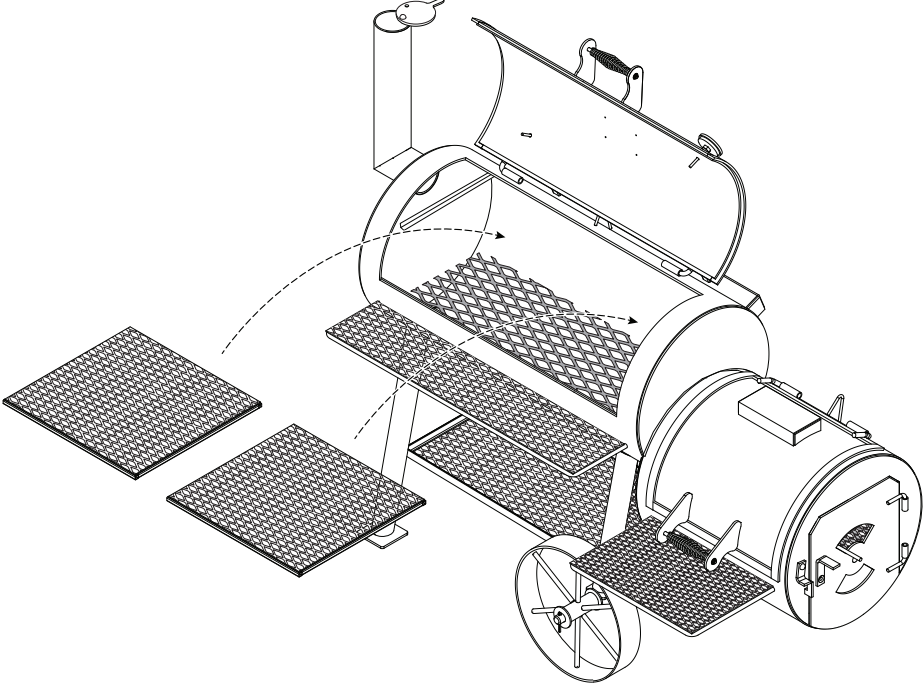

FIG 15

Grill Maintenance

Preparing the Grill for the Season

Begin with a thorough inspection of the entire grill correcting any issues you find. Follow the steps found in the Pre-Grill checklist (Page 8).

Painted Surfaces

Yoder smokers are painted with high heat silicone based paint. When cleaning the smoker, surfaces should be washed down with warm soapy water using a neutral detergent and rinsed with clean water. For more information about high heat paint that can be used for touch-up, contact service@yodersmokers.com.

Cooking Grates

When new, wash the grates thoroughly with warm soapy water, place back in the smoker and lightly coat with vegetable oil. Condition the grates during the burn off process.

When you begin the next cooking session, bring the grill up to the desired cooking temperature and use a long handled grill brush to clean the grates.

Heat Management Plate

Clean excess grease using a plastic scraper and paper towels and then wash with warm soapy water.

Cooking Chamber

It is recommended that each time you run through the steps in the Pre-Grill checklist (Page 8) that you inspect and thoroughly clean the interior of the cooking chamber. Any excess grease can be cleaned up using a plastic scraper and paper towels. At the beginning of the season and then as often as needed you should de-grease the interior with citrus based cleaning solution.

- Ensure that the grill is **completely cold** before using a shop vacuum or before scooping out and disposing of the ashes. Dispose of the ashes in a metal container.
- Use a citrus based cleaning solution to clean the entire inside of the body.

Grease Management Area and Bucket

Always be sure the cooking chamber area is clean and free of debris and empty the grease bucket regularly.

Additional Maintenance:

In addition to regular cleaning, perform the following procedures every 30 days:

1. Use a stiff brush to remove any build-up on the inside walls of your grill. Inspect and clean the inside of the door and the inside walls of the cooking chamber.
2. When your grill is cool to the touch use a shop vacuum to thoroughly clean the cooking chamber and firebox.
3. Use a citrus based cleaning solution to thoroughly clean the inside of the smoker.
4. Finally, visually inspect the painted surfaces and touch up any scratches with high heat flat black paint. Touchup paint can be purchased from Yoder Smokers. Call 1-877-409-6337.

Storing Your Grill

Cover your Yoder Smoker to protect it from the weather. If storing your cooker inside, be sure the smoker is cool to the touch before moving it inside. Inspect the firebox and cooking chamber for any remaining embers before storing the unit.

		<u>Frequency</u>			
		Every Use	Every 3 Uses	Every 7 Uses	Once A Year
<u>Maintenance Tasks</u>	Clean Cooking Grates p.16	X			
	Vacuum Ash From Cooking Chamber p. 16		X		
	Clean Heat Management Plate p. 16		X		
	Check Grease Bucket p. 17			X	
	Clean Body Of Smoker p. 16				X

WOOD FLAVOR GUIDELINES

WOOD	FLAVOR	BEST WITH
Apple	Sweet, fruity smoke. Strongest of the fruit woods	Beef, Pork, Ham, Poultry, Game
Black Walnut	Strong smoke, slightly bitter like walnuts.	Beef, Pork, Ham, Game
Cherry	Sweet fruity smoke that gives a rosy tint to the meats	Beef, Pork, Poultry, Fish, Game Birds
Hickory	Bacon-Flavor, most commonly used and recognized smoke	Beef, Pork, Poultry, Fish, Game
Mesquite	Spicy, very distinctive smoke of southwestern cooking	Beef, Pork, Poultry, Fish, Game
Mulberry	Sweet, tangy, blackberry smoke flavor	Pork, Ham, Poultry, Game Birds
Oak	Heavy smoke with no after-taste, gives foods a wonderful smoked color	Beef, Pork, Poultry, Fish, Game
Pecan	Similar to hickory but milder and sweeter with a nut after-taste	Beef, Pork, Poultry, Fish, Game
Sugar Maple	Very mild, a sweet light smoke	Pork, Ham, Poultry, Game Birds

Wood Usage

Most Yoder backyard models, with an average 10-hour cook, you will consume less than one cubic foot of wood.

How Often Do I Maintain My Fire?

Expect to add one 14 - 16" small split log to the fire every hour or so. The key to excellent color and a savory smoke infused flavor is running a small hot fire. When the fire is running efficiently you will have a thin light colored smoke coming from the stack.

NOTE: A heavy white smoke indicates that you are smoldering and not efficiently burning the wood. This will put a dark color and a harsh taste on your meat.

Meat Temperature Guide

Doneness	Internal Temperature	Internal Description
Beef, Lamb, Veal		
Steaks, Roasts and Chops		
(USDA Safe Minimum Cooking Temperature 145 Degrees F)		
Rare	120 to 130 Degrees F	Center is bright red, pink towards the exterior portion, warm
Medium Rare	130 to 140 Degrees F	Center is pink, starting to brown towards the edges, warm
Medium	140 to 150 Degrees F	Center is light pink, edges are brown, hot
Medium Well	150 to 160 Degrees F	Tan throughout with a hint of pink center
Well Done	160 Degrees and Above	Evenly brown or grey throughout
Ground Meats, Sausages, Meat Loafs		
(USDA Safe Minimum Cooking Temperature 165 Degrees F)		
Safe for Consumption	165 Degrees F	Tan, no sign of pink
Pork		
Steaks, Roasts and Chops		
(USDA Safe Minimum Cooking Temperature 145 Degrees F)		
Medium	145 Degrees F	Cream in color, pink to clear juices
Well Done	160 Degrees F	Cream or white in color, clear juices
Brisket, Pork Shoulder, Pork Ribs		
Tender and Juicy	190 Degrees F	Tender, clear juices
Poultry		
(USDA Safe Minimum Cooking Temperature 165 Degrees F)		
Safe for Consumption	165 Degrees F	Juices are clear
Fish		
(USDA Safe Minimum Cooking Temperature 145 Degrees or Flesh is Opaque and Separates Easy with a Fork)		
Rare	125 Degrees F	Color is similar to the raw meat
Medium	135 Degrees F	Fish is slightly translucent and will flake easily
Well Done	145 Degrees F	Fish is opaque and will flake easily
Scallops		
(USDA Safe Minimum Cooking Recommends Cook Until Flesh is Milky White or Opaque and Firm)		
Safe for Consumption		Should be white or opaque and firm
Shrimp		
(USDA Safe Minimum Cooking Recommends Cook Until Flesh is Pearly and Opaque)		
Safe for Consumption		Cook until shrimp is pearly and opaque

Warranty Information

Yoder Smokers warrants this barbecue unit against defects in material and workmanship under normal residential use and maintenance. Yoder Smokers warrants the cooking body for the lifetime from date of purchase against defects in material and workmanship under normal residential use and maintenance.

Yoder Smokers will provide a replacement part for any part found by Yoder Smokers to be defective and shall not be responsible for any re-assembly. Original part(s) approved for return by the Yoder Smokers Service Department must be returned prepaid by customer.

Customer should inspect the unit on purchase for any defects and immediately contact the retailer and notify any apparent damage for which the retailer may be responsible

This warranty does not include labor charges connected with the determination of replacement of defective parts, or freight charges to ship these parts.

Yoder Smokers shall not be liable under this, or any implied warranty for incidental, special, or consequential damages or any damage or defect to finish on the unit. In no event shall Yoder Smokers' obligation to customer exceed the purchase price of the unit. This warranty gives customer specific legal rights and customer may have other rights which vary from state to state. In consideration of this warranty, customer agrees that any dispute related to the unit or this warranty shall be tried in Sedgwick County, Kansas and subject to Kansas law.

This warranty shall be void if the unit is not assembled or operated in accordance with the operation instructions provided with the unit, the unit is exposed to unreasonable or extreme weather conditions, components, accessories, or fuels not compatible with the unit have been used, the unit has been used in a commercial or food service application, or the user has abused or otherwise failed to maintain, cover, or properly store the unit depending on weather conditions.

To process a warranty claim, Yoder Smokers will require proof of customer's date of purchase from the retailer and must be in timely receipt of the warranty. Customer must retain its sales slip or invoice along with this certificate with your valuable documents for this warranty to be valid.

THE AGREEMENT IS IN LIEU OF ALL OTHER WARRANTIES, STATUTORY OR OTHERWISE, EXPRESS OR IMPLIED, ALL OTHER REPRESENTATIONS MADE BY YODER SMOKERS OR ANY THIRD PARTY DISTRIBUTOR OR RETAILER AND ALL OTHER OBLIGATIONS OR LIABILITIES WITH RESPECT TO THE UNIT COVERED BY THIS AGREEMENT WHICH, AT THE TIME OF PURCHASE OR AT ANY TIME IN THE FUTURE, MAY BE MADE AGAINST YODER SMOKERS, ITS OFFICERS, DIRECTORS, EMPLOYEES, AND AGENTS. EXCEPT AS EXPRESSLY PROVIDED HEREIN, YODER SMOKERS GIVES NO OTHER EXPRESS OR IMPLIED WARRANTIES RELATING TO FITNESS FOR USE OF THE UNIT; MERCHANTABILITY OF THE UNIT, FITNESS FOR A PARTICULAR PURPOSE OF THE UNIT, QUALITY OF THE UNIT; OR CONDITION OF THE UNIT. YODER SMOKERS OBLIGATIONS SHALL NOT EXCEED ITS OBLIGATION EXPRESSLY SET FORTH IN THIS AGREEMENT.

Yoder Smokers provides no representation, warranty, or promise relating to damages or defects in the unit which are the result of: (i) ordinary wear and tear; (ii) failure of customer to provide normal maintenance or proper care of the unit; (iii) characteristics common to materials used; (iv) natural disaster; (v) loss; or (vi) injury caused in any way by natural elements, changes made to the unit by the customer, or any misuse, negligence, recklessness, or intentional act or acts of any person.

Warranty Registration Form

Register online at www.yodersmokers.com/warranty-registration-form or complete and return the Warranty Registration form within 30 days of purchase.

**required field*

First Name* _____

Last Name* _____

Mailing Address* _____

City* _____

State/Province* _____

Postal Code* _____

Country* _____

Phone Number _____

Email _____

Model* _____

Serial Number* _____

Send Warranty Registration and dated sales receipt to:

Yoder Smokers
Yoder Warranty Registration
1816 E Wasp Rd
Hutchinson, KS 67501

Contact our customer service with any questions at
877.409.6337 or at info@yodersmokers.com

★ **YODER SMOKERS** ★
COMPETITION GRADE BBQ PRODUCTS