

EASYPURE Powder & Liquid

Polymer preparation and dosing station, 3-chamber tunnel machine



For clean separation

EASYPURE Powder & Liquid is a fully automatic system for the continuous preparation of powder and liquid polymer dosing solutions. The 3-chamber system largely avoids displacements of the prepared polymer.

Easy to operate

Comfortable operation of the EASYPURE Powder & Liquid polymer preparation and dosing station using a control integrated with the control cabinet. The control is used for configuring the system. The control cabinet has a display for operation.

The EASYPURE Powder & Liquid polymer preparation and dosing station can run in manual or automatic operation. In automatic operation, it works fully automatically and requires no further settings.

Once the water supply has been established, the system will automatically convey the required amount. The dry material can be provided automatically or manually. If it is provided manually, the feed hopper for the dry material needs to be filled.

A corresponding configuration ensures that a dosing pump automatically removes the finished solution.

Functions

- 3-chamber system
- Processing of powder and liquid polymers
- Easy to operate
- Control in the control cabinet
- Multilingual operating display
- Manual and automatic operation
- Fill level monitoring
- Delivery rate up to 10000 l/h

Areas of application

- Waste water and sludge treatment
- Paper manufacture
- Drinking and industrial water treatment
- Sand and gravel treatment
- Brine treatment
- Ore concentration
- Waste water treatment in power stations
- Recycling of process and recirculation systems
- Lot treatment
- Electroplating waste water
- Chemical industry
- Landfill seepage water treatment

Product description

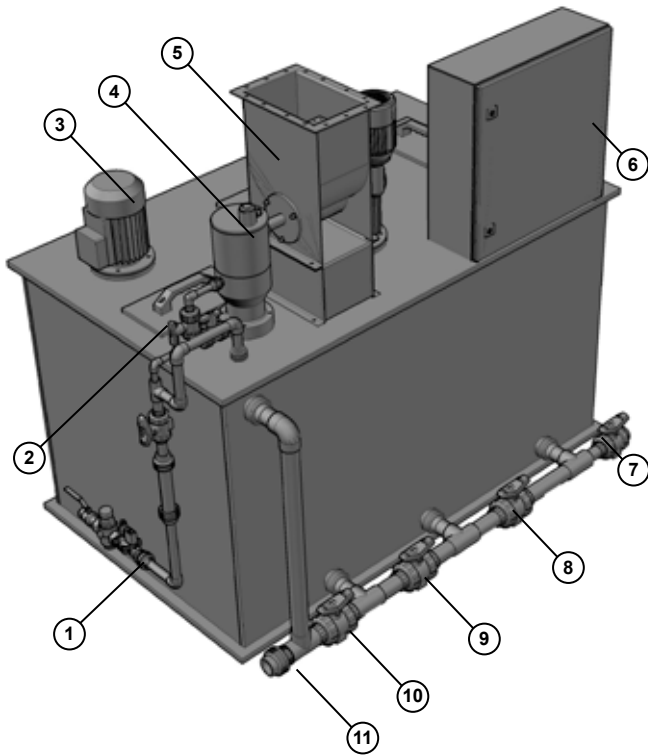

Item	Description
1	Water equipment
2	Inspection cover (one per chamber)
3	Agitator (one per preparation and maturing chamber; optionally also in the dosing chamber)
4	Suspensomat
5	Dry feeder
6	Switch cabinet
7	Dosing chamber exit with shutoff valve
8	Maturing chamber shutoff valve
9	Preparation chamber shutoff valve
10	Overflow shutoff valve
11	Overflow exit

Specifications

Description		Polymer preparing and dosing station EASYPURE Powder and Liquid							
		500	1000	2000	3000	4000	5000	6000	10000
Operating pressure	bar	2 – 6							
Maturing time	min	60							
Concentration	%	0.1 – 0.5							
Permissible grain size	mm	1		2				3	
Nominal water consumption	l/h	500	1000	2000	3000	4000	5000	6000	10000
Protection class	IP	IP54							
Permissible ambient temperature	°C	+5 to +40							
Maximum viscosity	mPas	2500							

Dimensions

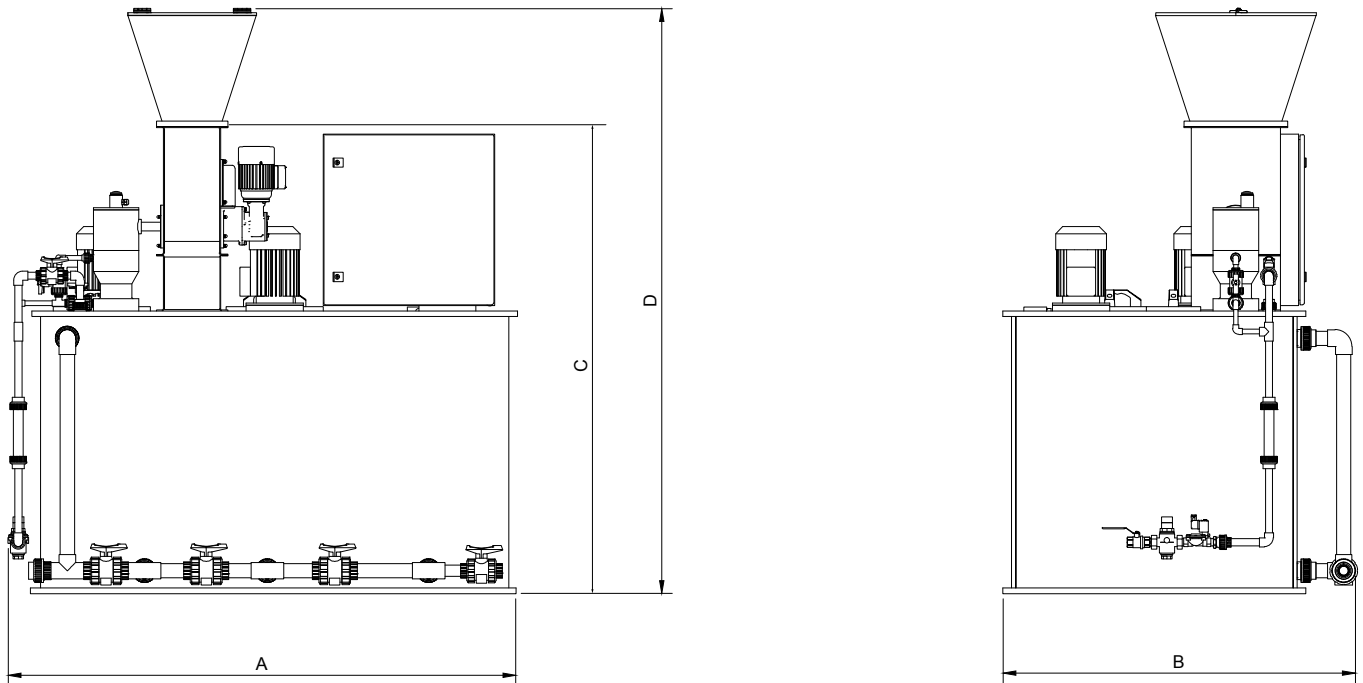

Size	A	B	C	*D
EASYPURE 500	1700	1200	1540	1600
EASYPURE 1000	2000	1350	1540	1600
EASYPURE 2000	2300	1450	1940	2000
EASYPURE 3000	2700	1600	1940	2000
EASYPURE 4000	3200	1750	1940	2000
EASYPURE 5000	3300	1850	1940	2000
EASYPURE 6000	3500	1850	2140	2200
EASYPURE 10000	3900	1850	2140	2200

*optional supply funnel

EASYPURE Powder & Liquid accessories



Post-dilution

Post-dilution

Completely pre-assembled incl. PP mounting plate; Ms ball valve; pressure reducing valve incl. pressure gauge; solenoid valve is closed if there is no current; flow meter with min. contact as water deficiency protection.

PVC diaphragm valve for adjusting the flow; Lusap mixer (static mixer).

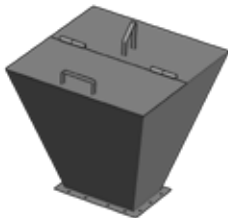

Feed hopper

Feed hopper

With a volume of 50, 100, and 200 litres, made of PP and stainless steel.



Eccentric screw pump

Eccentric screw pump

For feeding with liquid polymers

Other accessories, such as rotary feeders, knife gate valves, suction conveyors and BigBags are available on request.