

## LIGHT SHADE

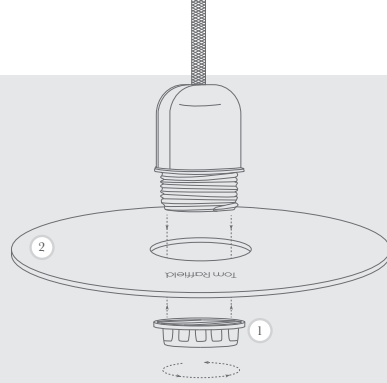

All Tom Raffield pendants including the shade supplied with the Mullion floor light have been designed to fit the wiring kit provided. Our pendant lights come as standard with 2 metre Satin Nickel wiring and are also designed to fit onto existing ceiling fittings.

**\* WIRING MUST BE INSTALLED BY A QUALIFIED ELECTRICIAN \***

To fit your lampshade to the lamp holder:

- Unscrew the screw cap exposing the thread of the lamp holder (Fig 1).
- Sandwich the disc of your lampshade between lamp holder and the screw cap (Fig 1 & 2).
- Ensure the screw cap is tight and the lampshade is secure.
- Reach inside the lampshade and screw in your chosen light bulb.

*If you have one of our No.1 Pendants, the disc of the lampshade is replaced by a smaller disc with small wooden pegs. This disc holds the lampshade in the correct position as detailed below.*

- Attach the lamp holder to the disc in the same way as above and screw in the bulb, ensuring the wooden pegs are facing upwards towards the ceiling.
- Slot the disc inside and under the two support arms as shown below.
- Position the No.1 Pendant so that the disc is in the middle of the support arms.

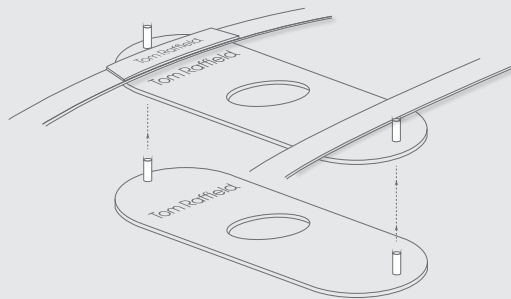

**\* CARING FOR YOUR LAMPSHADE \***

Our lighting collection uses a variety of naturally treated timbers – ash, oak and walnut – that are finished with a subtle water-based satin varnish. This provides an easy-to-care-for durable finish which doesn't compromise the natural beauty of the wood grain. Dusting your light regularly and with a light feather duster should keep your light looking clean, otherwise wipe with a damp cloth and remove any moisture with a dry cloth. Gentle furniture polishes can also be used.

## FLOOR LAMP WITH WOODEN FLOOR STAND

**\* Before you can attach your new lampshade to its floor stand, you first need to attach the legs of the tripod to the metal top plate (see Wooden Tripod Legs installation instructions). \***

To fit your lampshade to the lamp holder and metal top plate:

- Screw one of the screw caps to the base of the thread on the lampholder (Fig 1)
- Unscrew the other screw cap, exposing the thread of the lamp holder.
- Push the lamp holder up through the metal top plate (Fig 2) and then attach the disc of the lampshade to the metal floor plate (Fig 3) using the remaining screw cap, ensuring it is tight and the lampshade is secure (Fig 4)
- Reach inside the lampshade and screw in your chosen light bulb.

