

ART 260

PN16 Cast Iron Globe Valve

Features

- Flange Mounting PN16 Only
- BS EN558-1 Series 10
- Conforms to BS5152



Pressure / Temperature

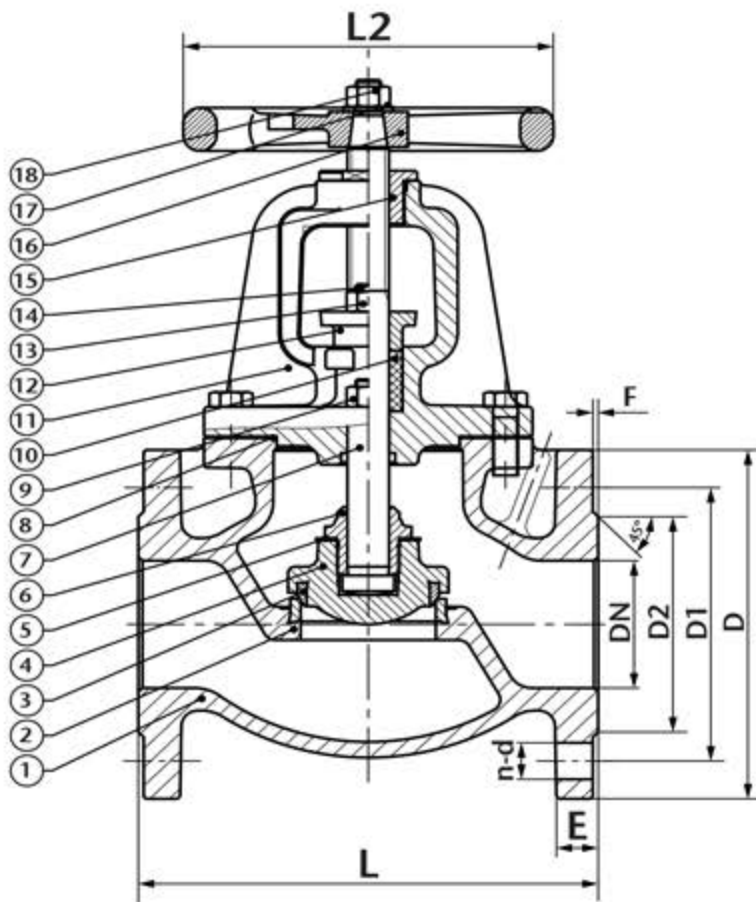
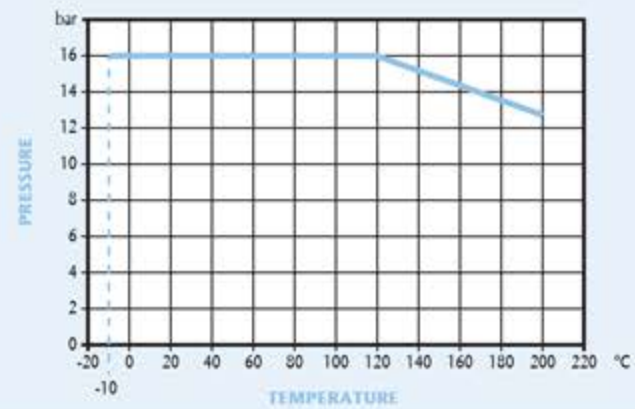

Technical Data

| | |
|---------------------|-----------------|
| Max Pressure | 16 Bar |
| Working Temperature | -10°C to +200°C |

| DN | 50 | 65 | 80 | 100 | 125 | 150 | 200 | 250 | 300 |
|-----|------|------|------|------|------|------|-------|-------|-------|
| D | 165 | 185 | 200 | 220 | 250 | 285 | 340 | 405 | 460 |
| D1 | 125 | 145 | 160 | 180 | 210 | 240 | 295 | 355 | 410 |
| D2 | 99 | 118 | 132 | 156 | 184 | 211 | 266 | 319 | 370 |
| E | 20 | 17.5 | 19.1 | 23.9 | 23.9 | 25.4 | 28.6 | 30.2 | 31.8 |
| F | 3 | 3 | 3 | 3 | 3 | 3 | 3 | 3 | 4 |
| L | 203 | 216 | 241 | 292 | 330 | 356 | 495 | 622 | 698 |
| L2 | 178 | 178 | 200 | 254 | 300 | 300 | 348 | 400 | 457 |
| n-d | 4-19 | 4-19 | 8-19 | 8-19 | 8-19 | 8-23 | 12-23 | 12-28 | 12-28 |

| N. | Part Name | Materials |
|----|---------------|---------------------|
| 1 | Body | Cast Iron |
| 2 | Body Ring | Cast Bronze |
| 3 | Disc Ring | Cast Bronze |
| 4 | Disc | Cast Iron |
| 5 | Stop Washer | Stainless Steel 304 |
| 6 | Nut | Cast Brass |
| 7 | Stem | Brass |
| 8 | Flange Gasket | Graphite |
| 9 | Bolt | Cast Iron |
| 10 | Packing | Graphite |
| 11 | Bonnet | Cast Iron |
| 12 | Gland | Ductile Iron |
| 13 | Nut | Steel |
| 14 | Bolt | Steel |
| 15 | Stem Nut | Cast Brass |
| 16 | Handwheel | Cast Iron |
| 17 | Washer | Steel |
| 18 | Nut | Steel |