

**GOZNEY°**

**Technical Manual**

# **Dome Stand**

This section details the process of building the stand and the correct installation of Dome Stand.

# 1

# Cautions & Warnings

## Cautions & Warnings



Ensure you have fully read, understood and comply with the cautions & warnings in the Dome Users Manual supplied with the oven.

—  
All four of the casters should always be locked unless you are moving the oven.

—  
Never attempt to move the oven when it is still warm, wait for it to fully cool first.

—  
When moving the oven on the stand always push/pull from the stand and not the oven.

Remove anything loose from the stand and its shelves before moving it.

—  
Placing hot items from the oven onto the wooden shelves may damage them, use appropriate protection to avoid damage.

## Gas Oven

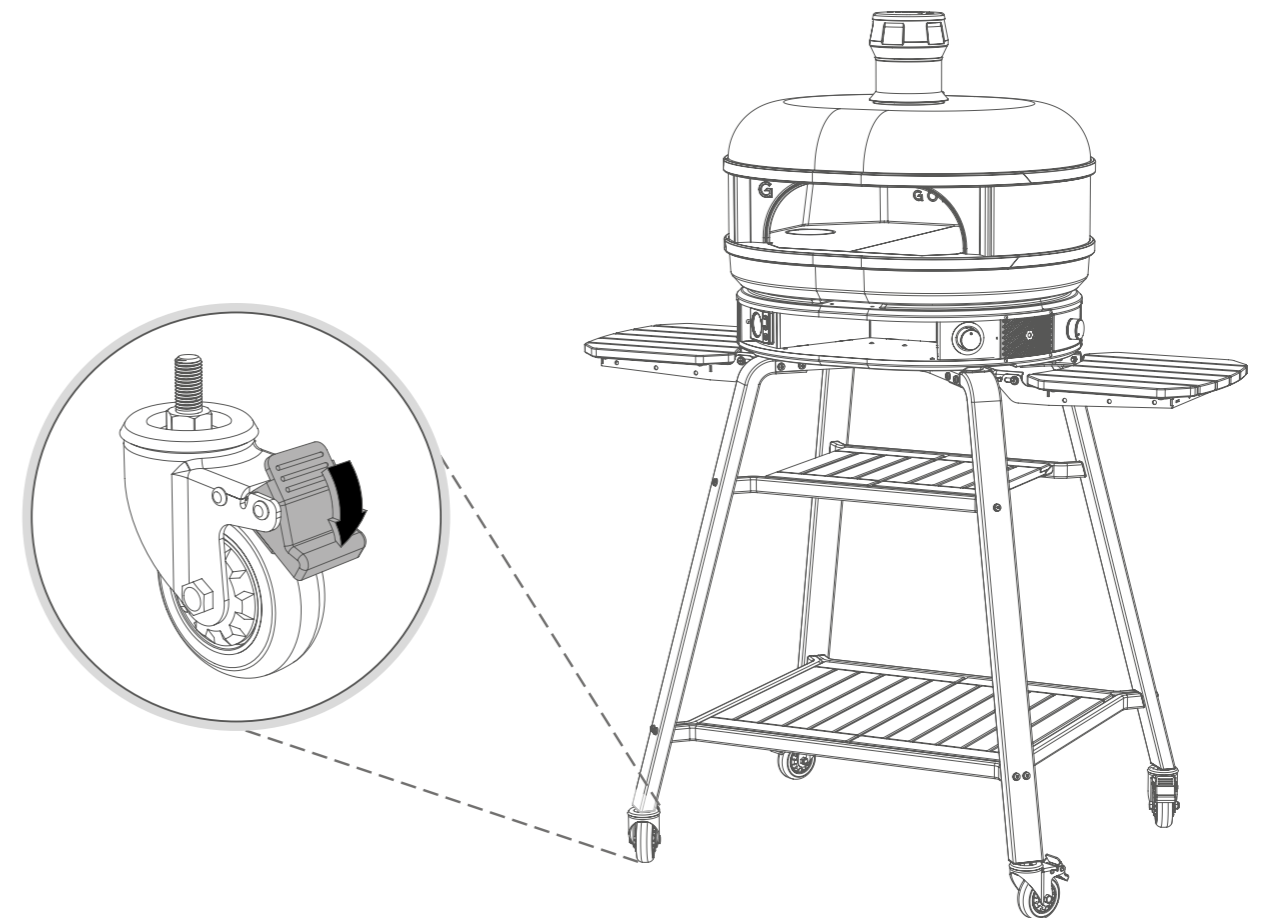

Always disconnect the oven from the gas supply before moving the oven.

—  
The casters should always be locked when the oven is connected to a gas supply, even if the oven isn't in use.

—  
Ensure you're using a Gozney supplied gas connector or one that complies with the Standard for movable gas appliances (ANSI Z21.69 / CSA 6.16), and a quick-disconnect device that complies with the relevant Standards (ANSI Z21.41 / CSA 6.9).

The gas connector and the quick disconnect device or its associated piping should never be used to limit the movement of the appliance.

This section details the process of building the stand and the correct installation of Dome Stand.

# 2

# Building & Installation

# Build Manual

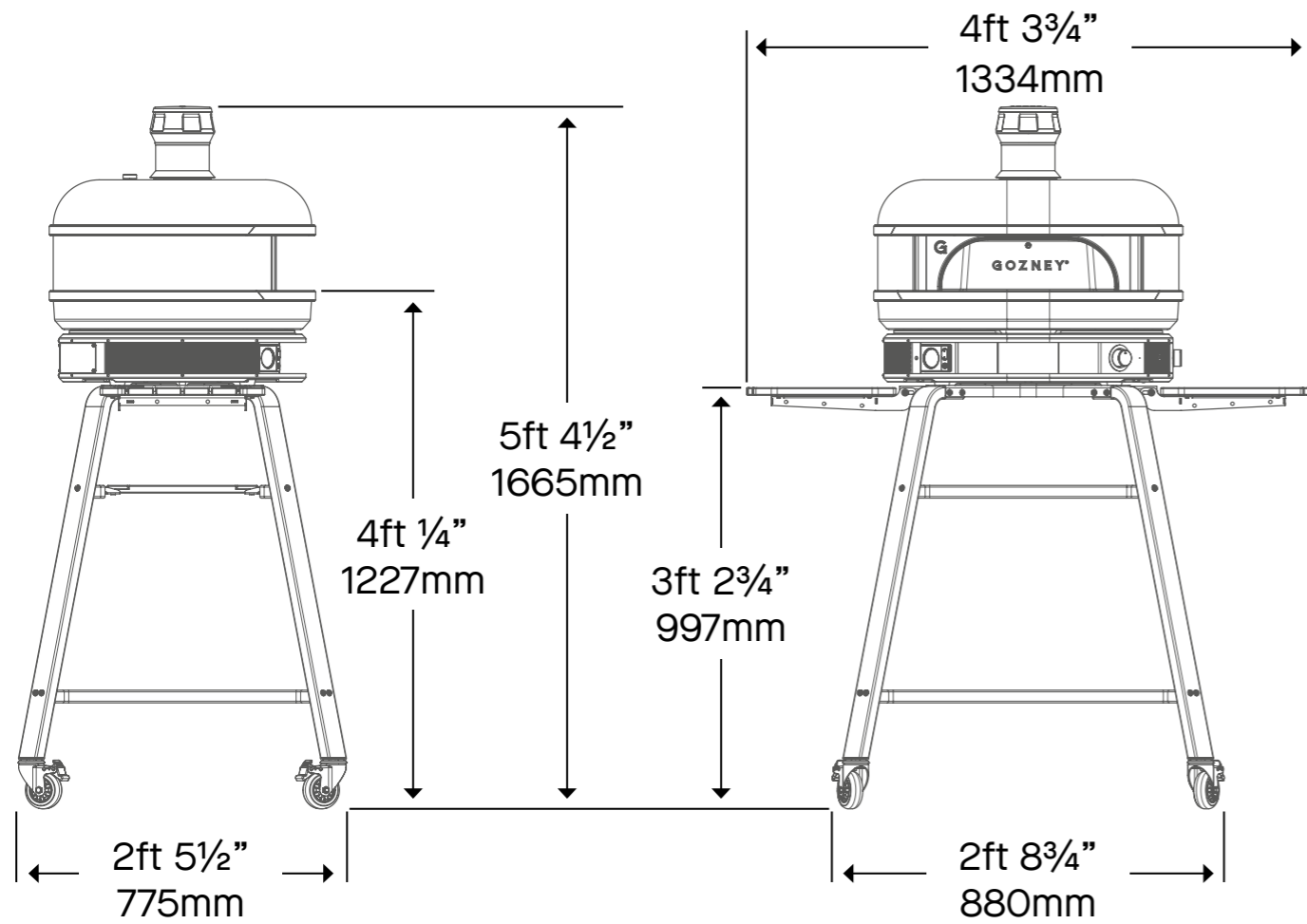

## BUILD AREA

Build the stand in front of the area you intend to position Dome.

Ensure the ground is stable and level and capable of supporting the oven's weight.

Don't place any of the parts on an abrasive surface and avoid damaging the paintwork of the metal parts.

# What's In The Box

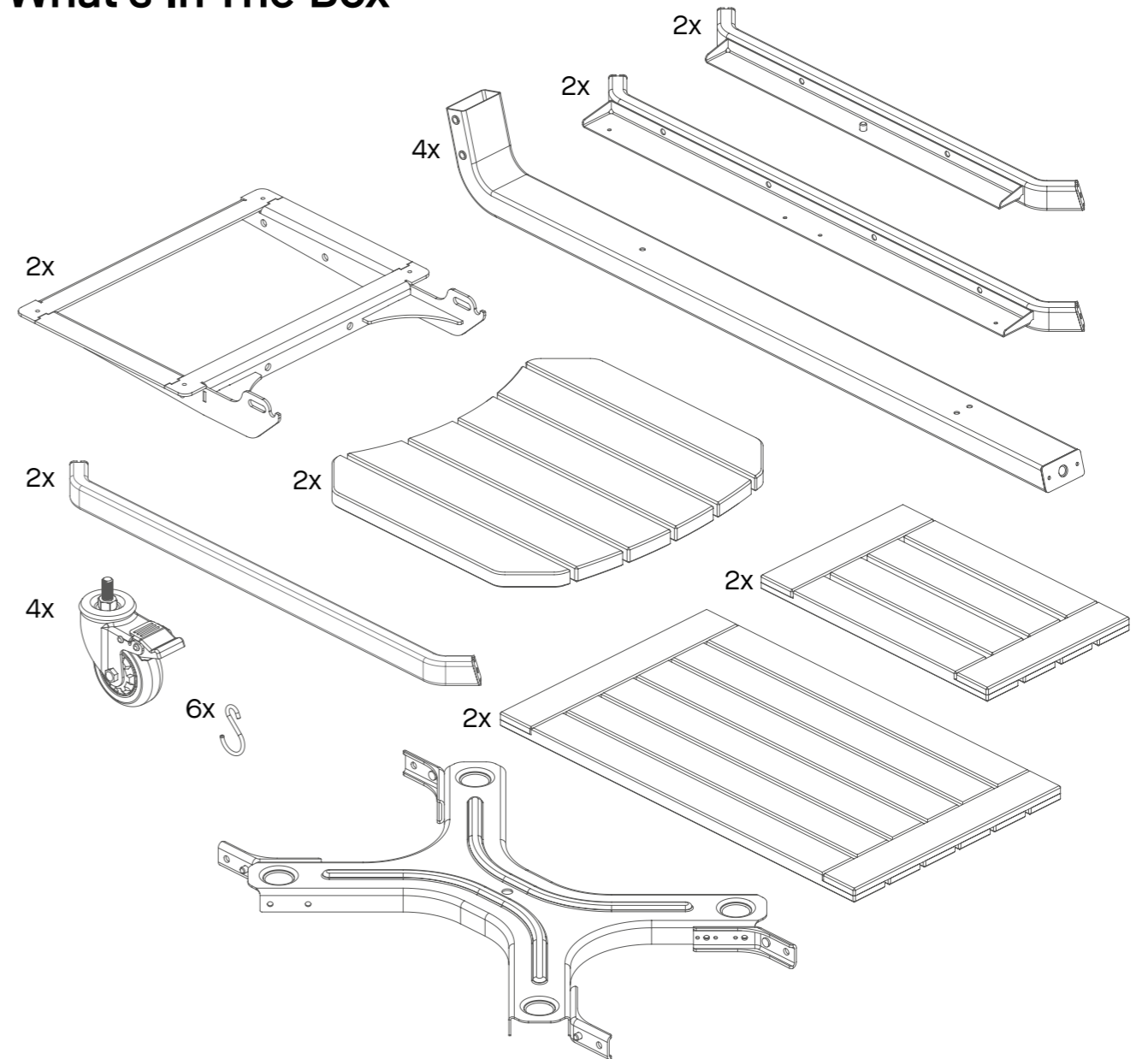

## SCALE 1:1

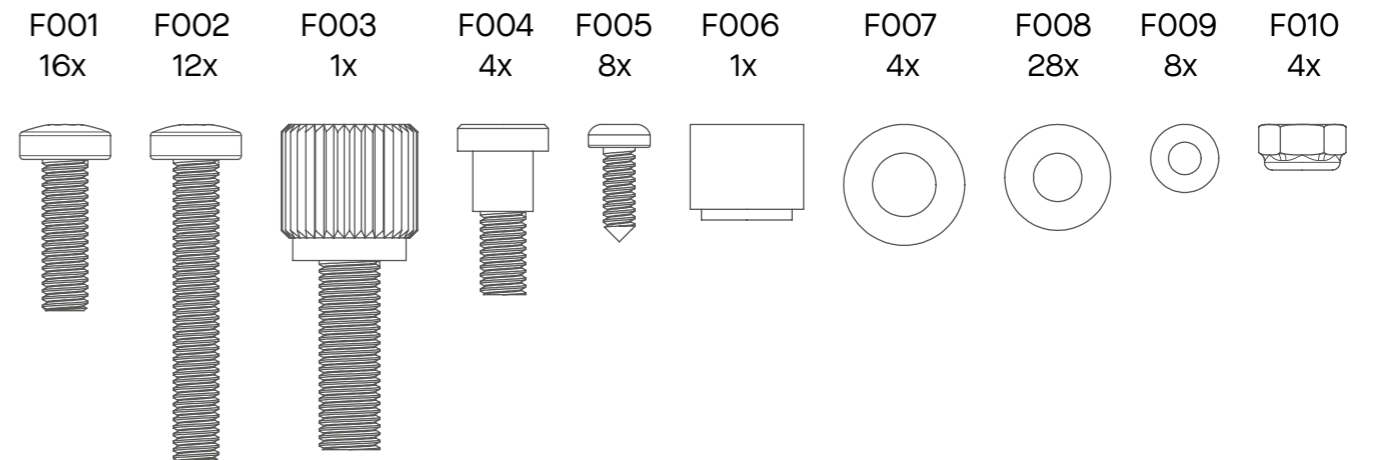

## Step 1

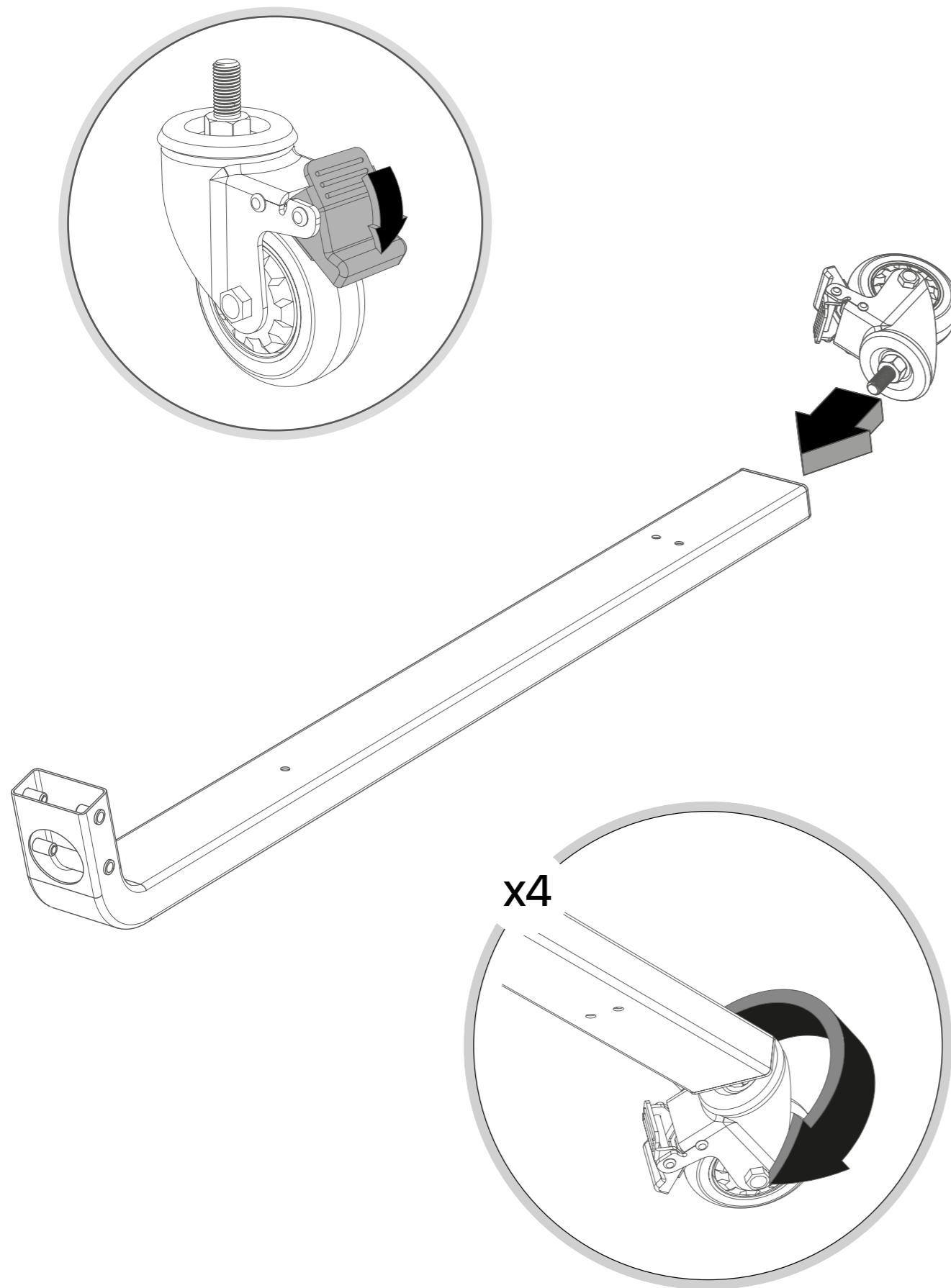

## Step 2

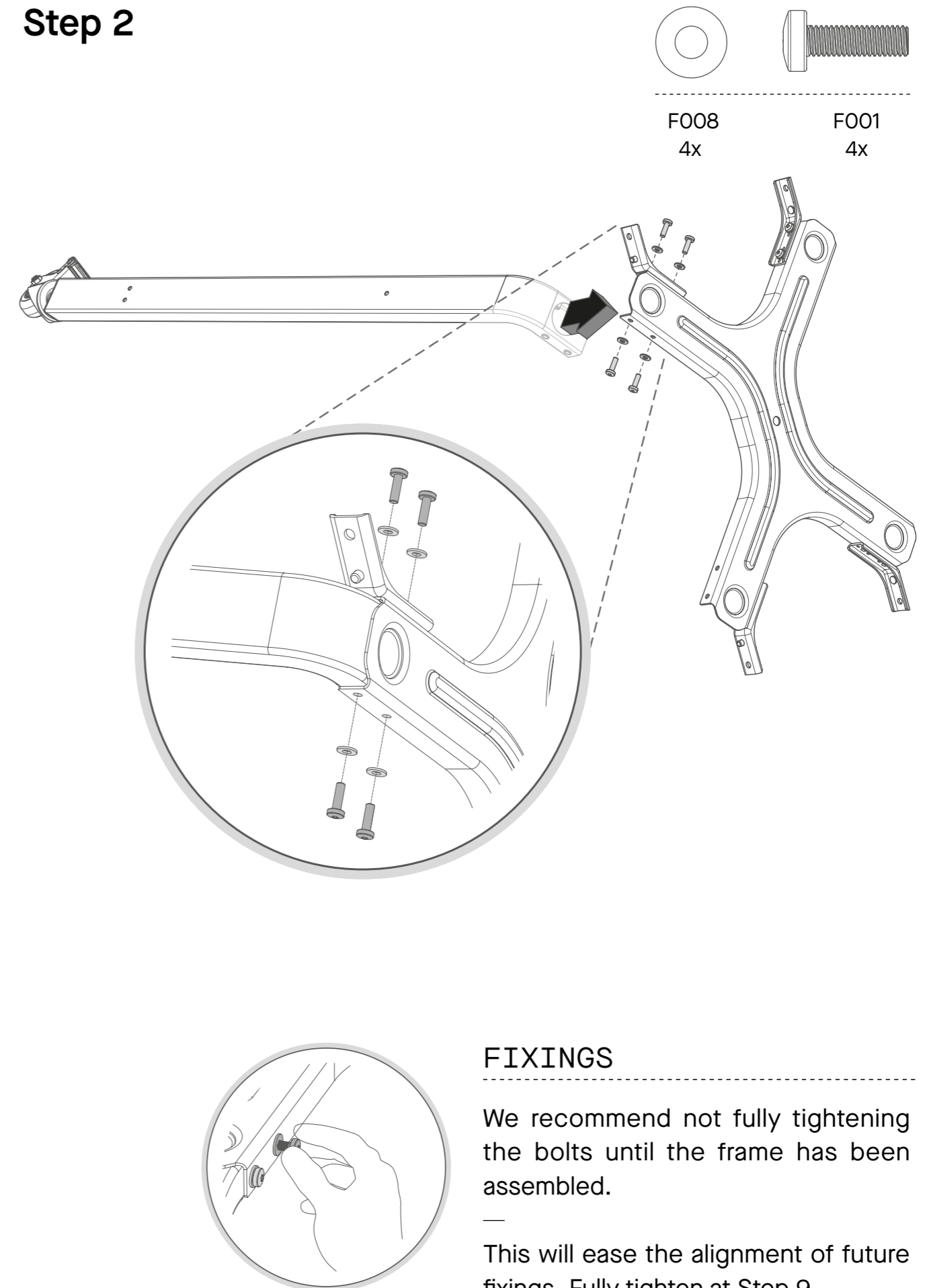

### Step 3

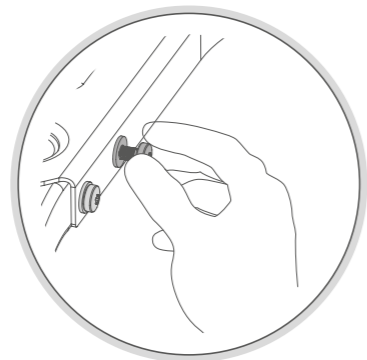
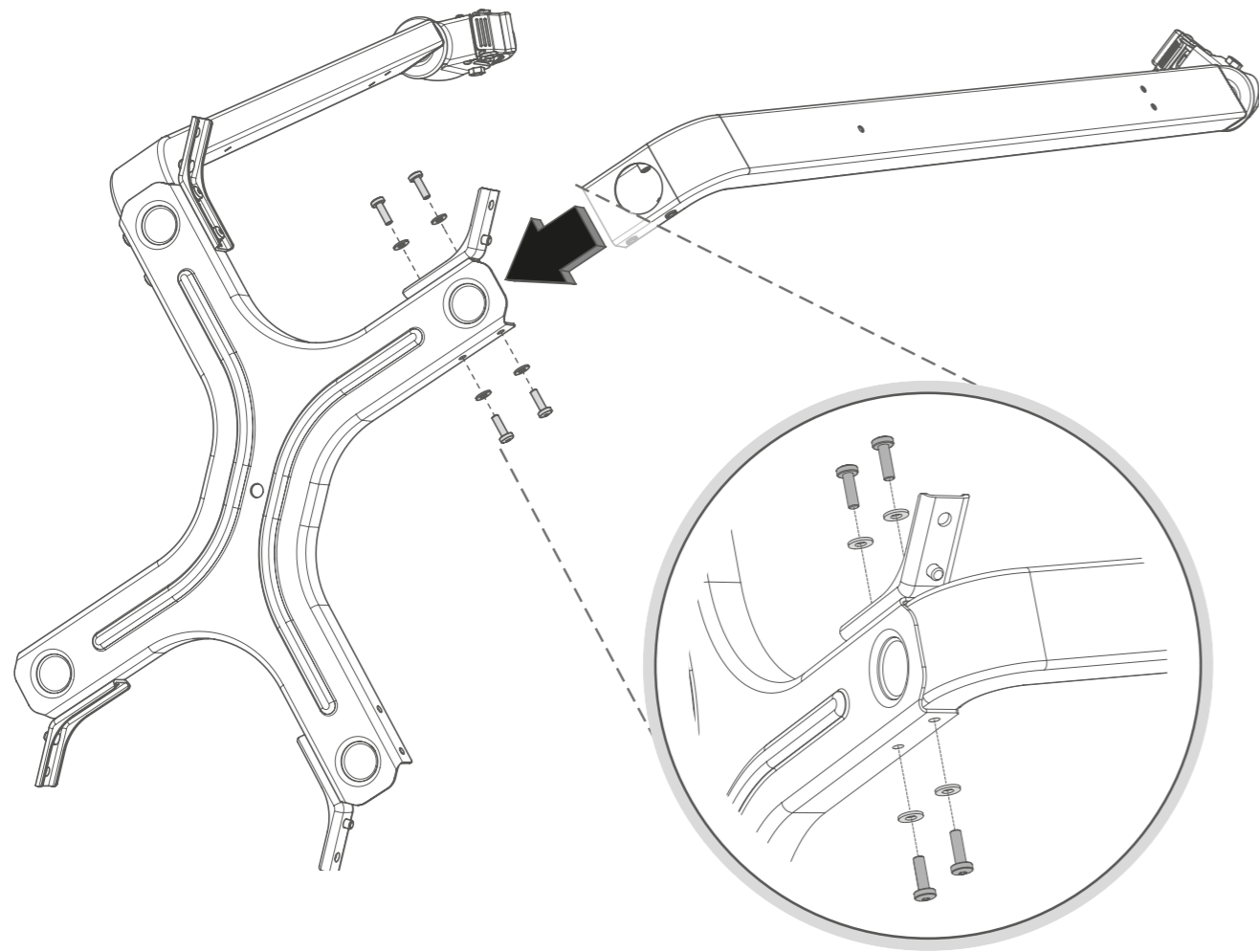
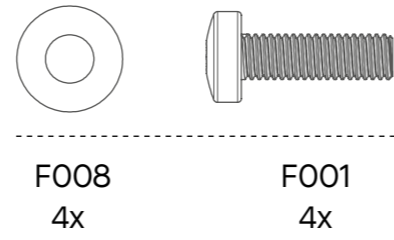

### Step 4

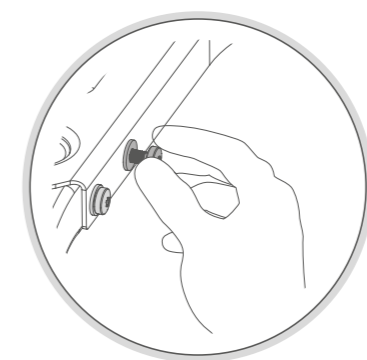
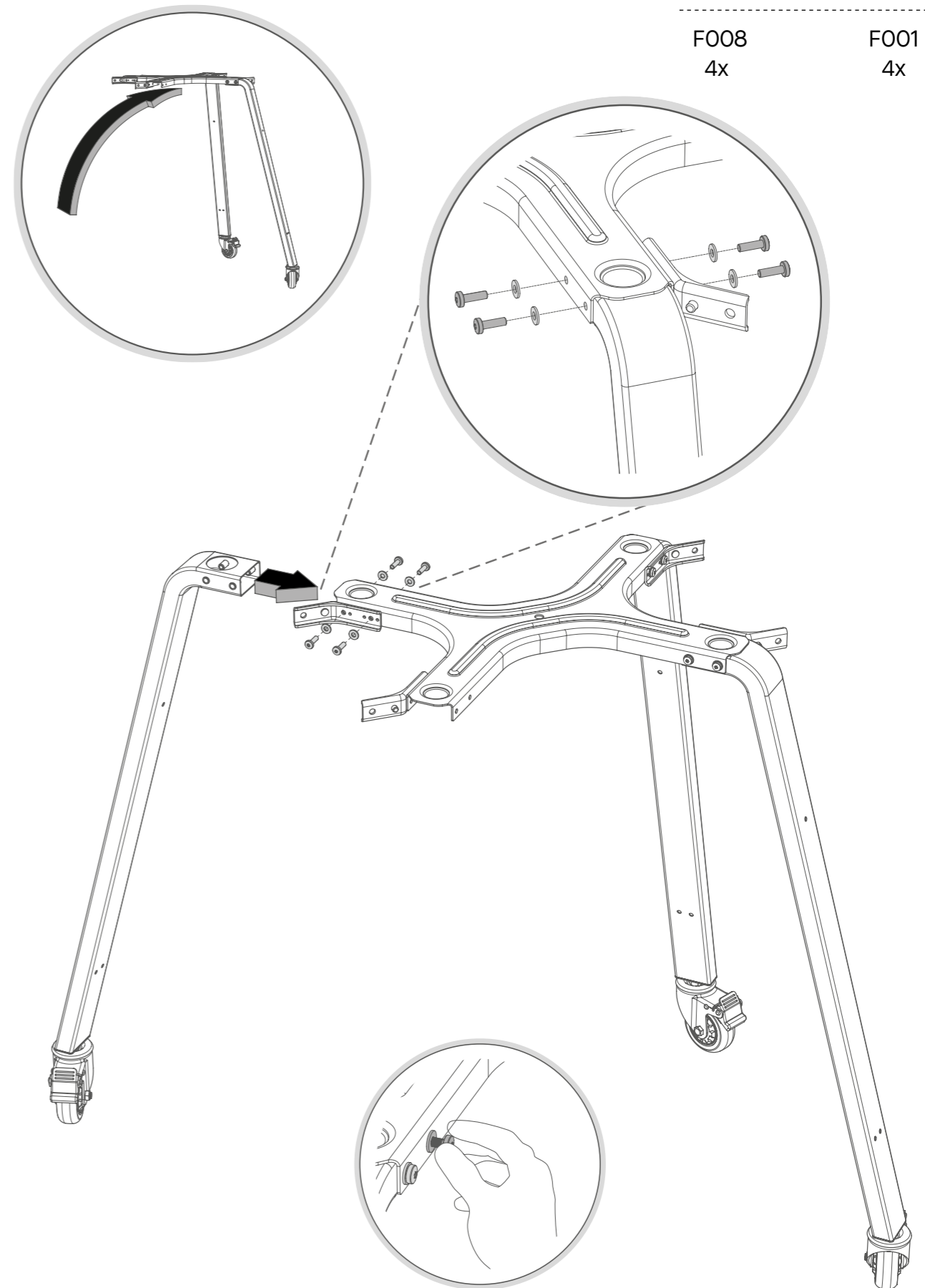
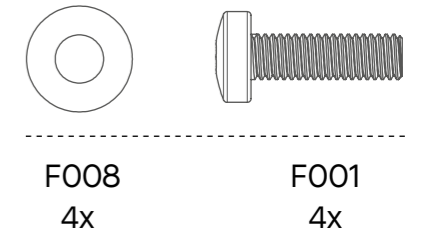

# Step 5

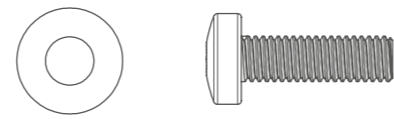

F008  
4x

F001  
4x

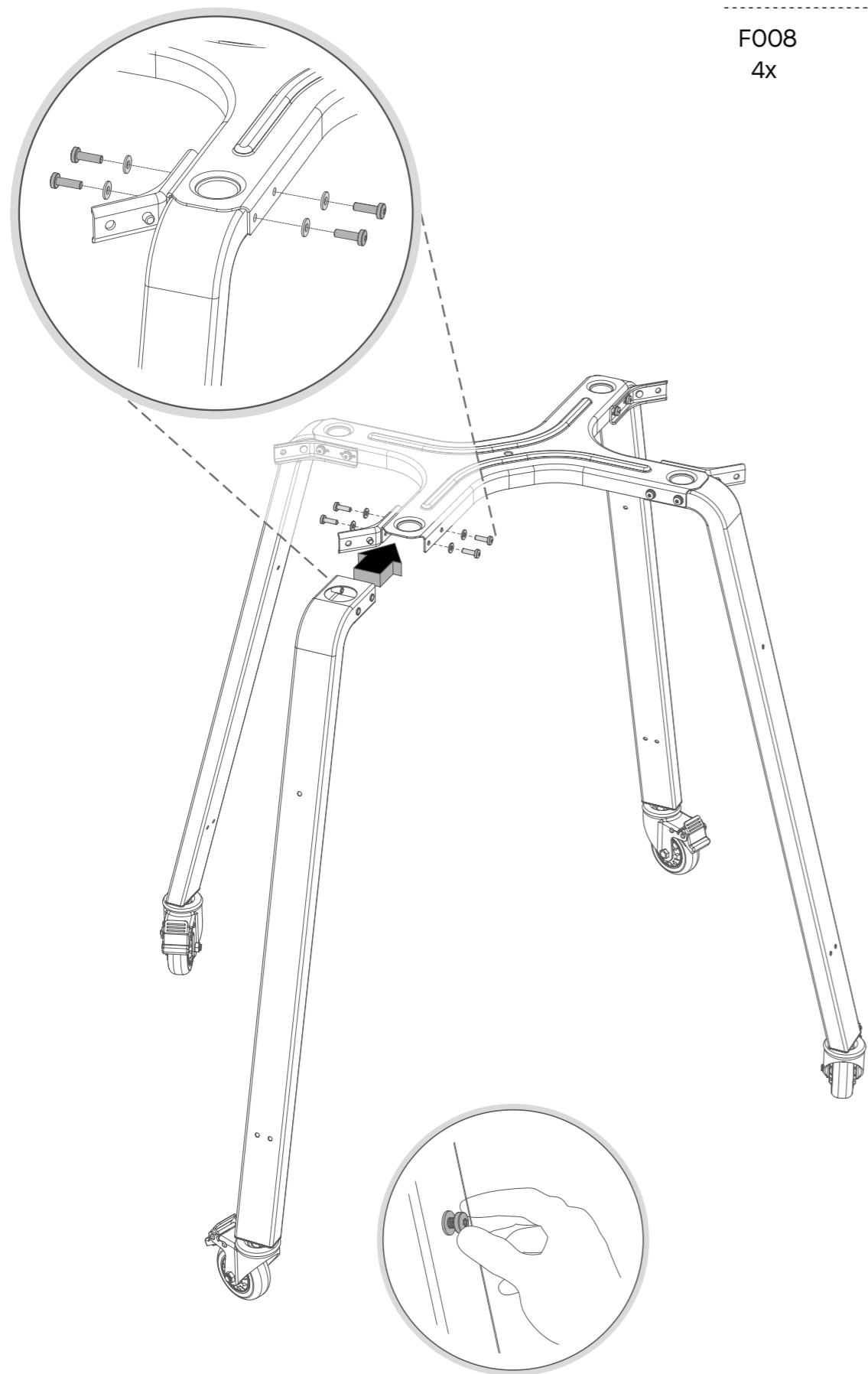

# Step 6

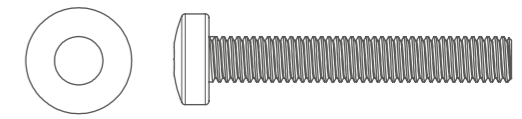

F008  
4x

F002  
4x

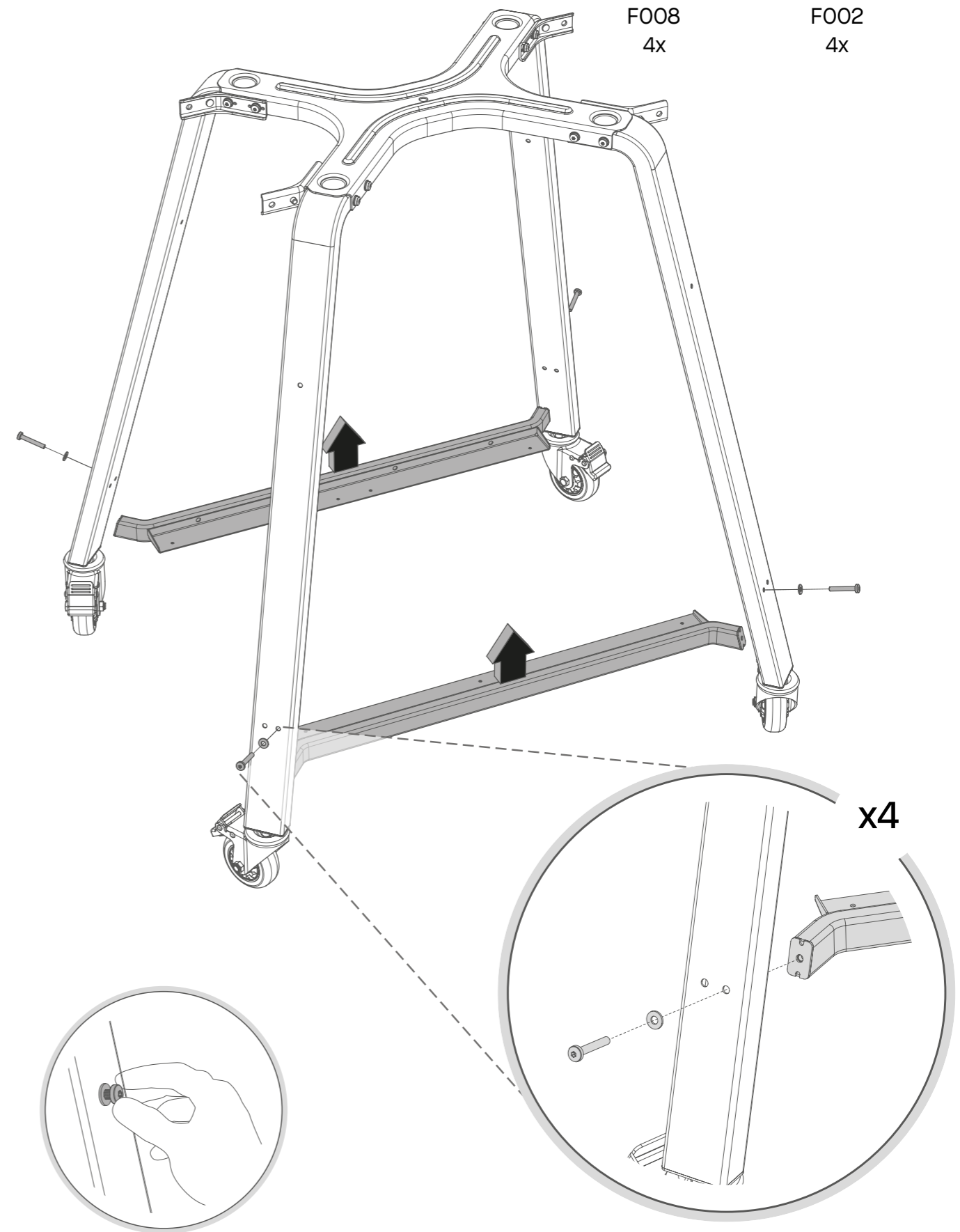



# Step 7

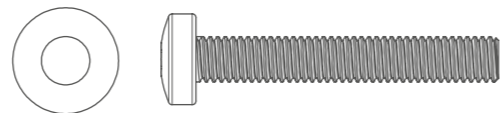

F008  
4x

F002  
4x

x4

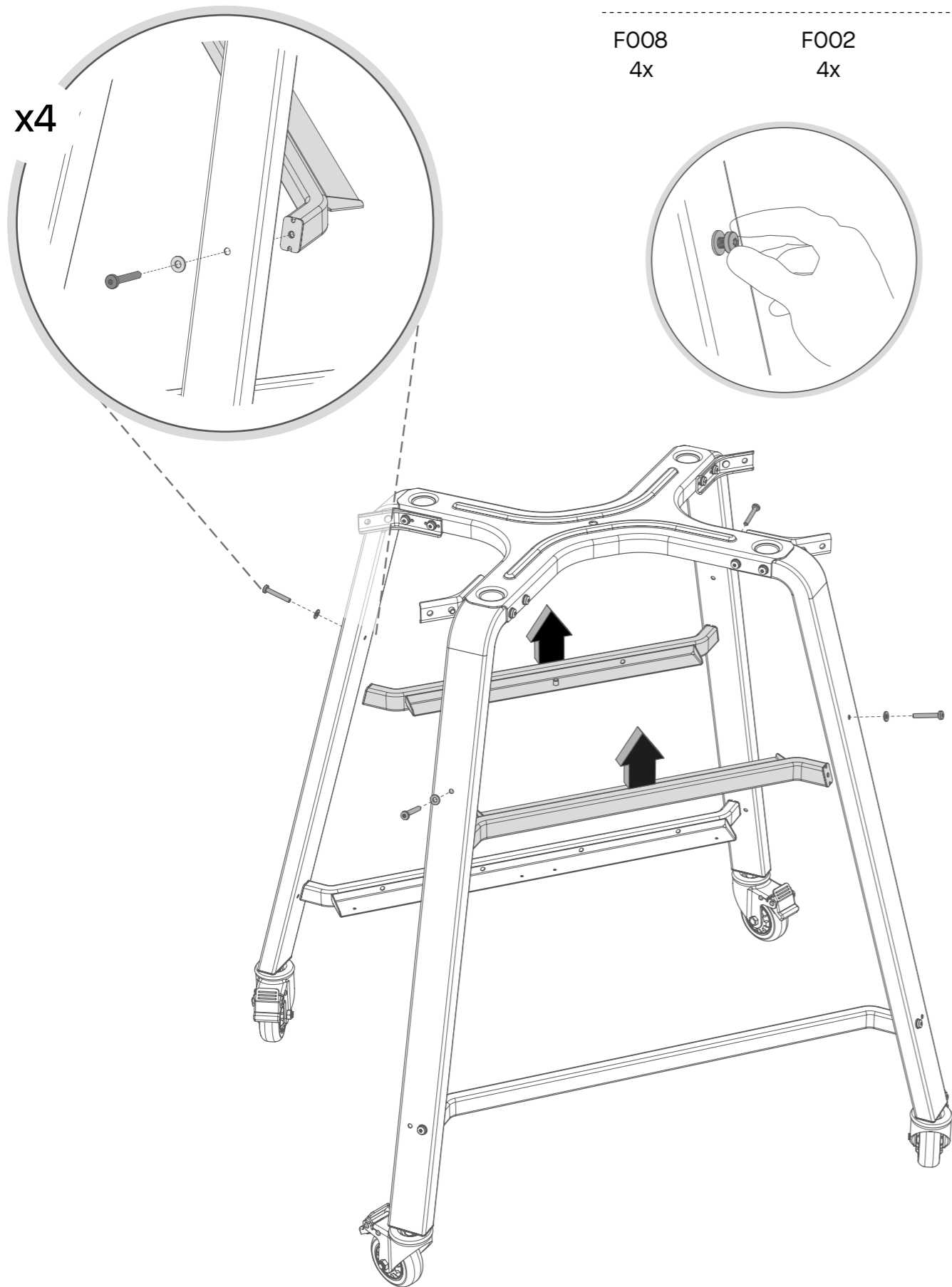

# Step 8

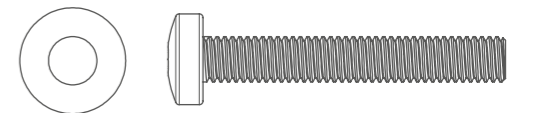

F008  
4x

F002  
4x

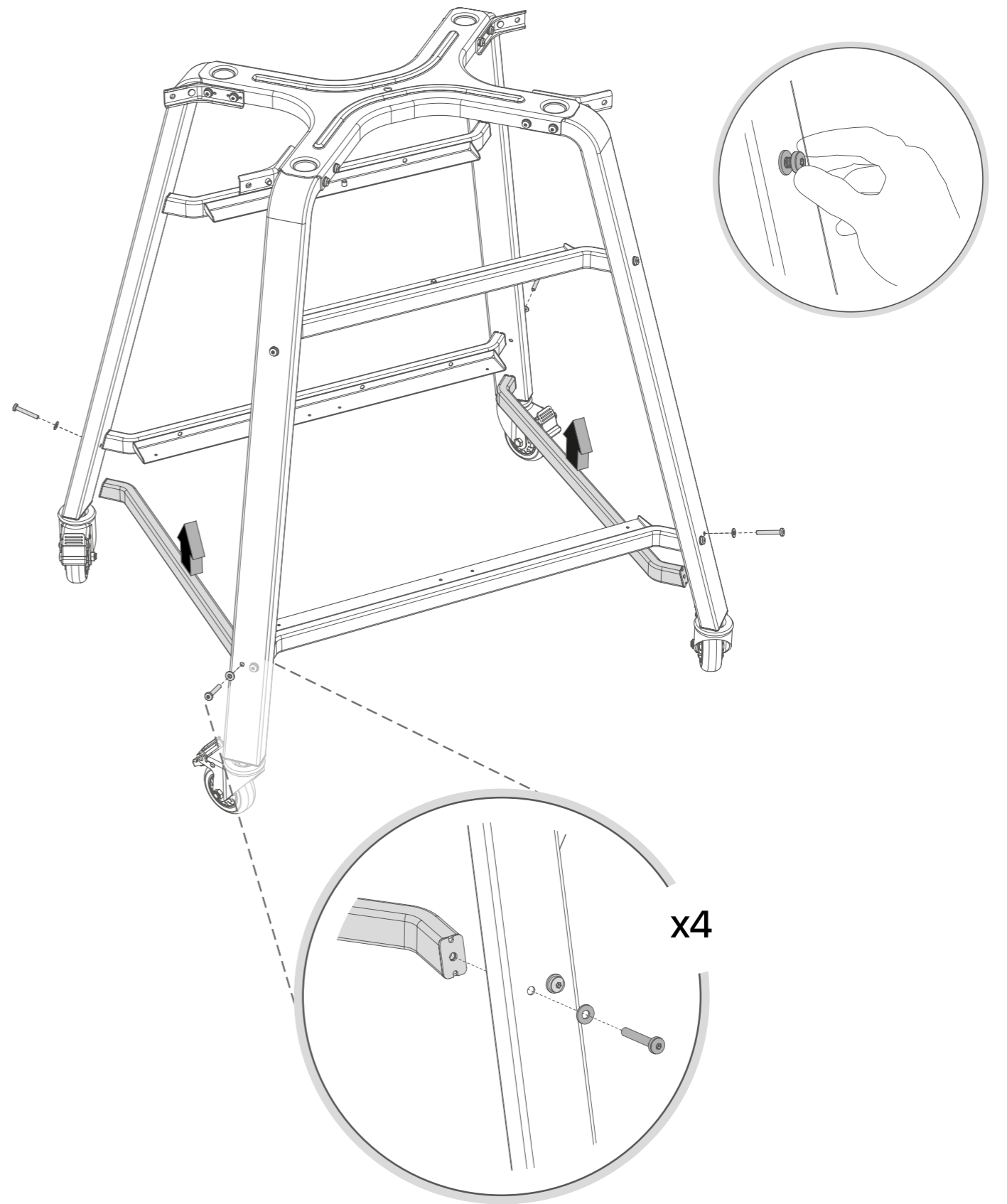

# Step 9

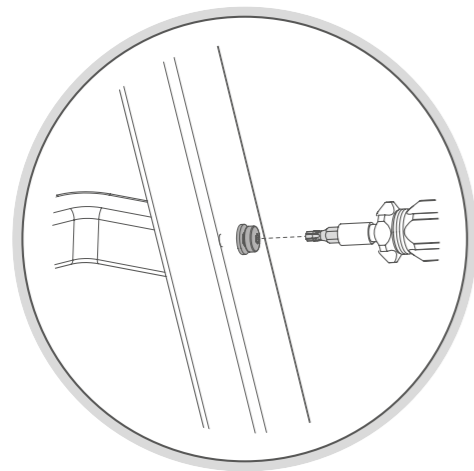
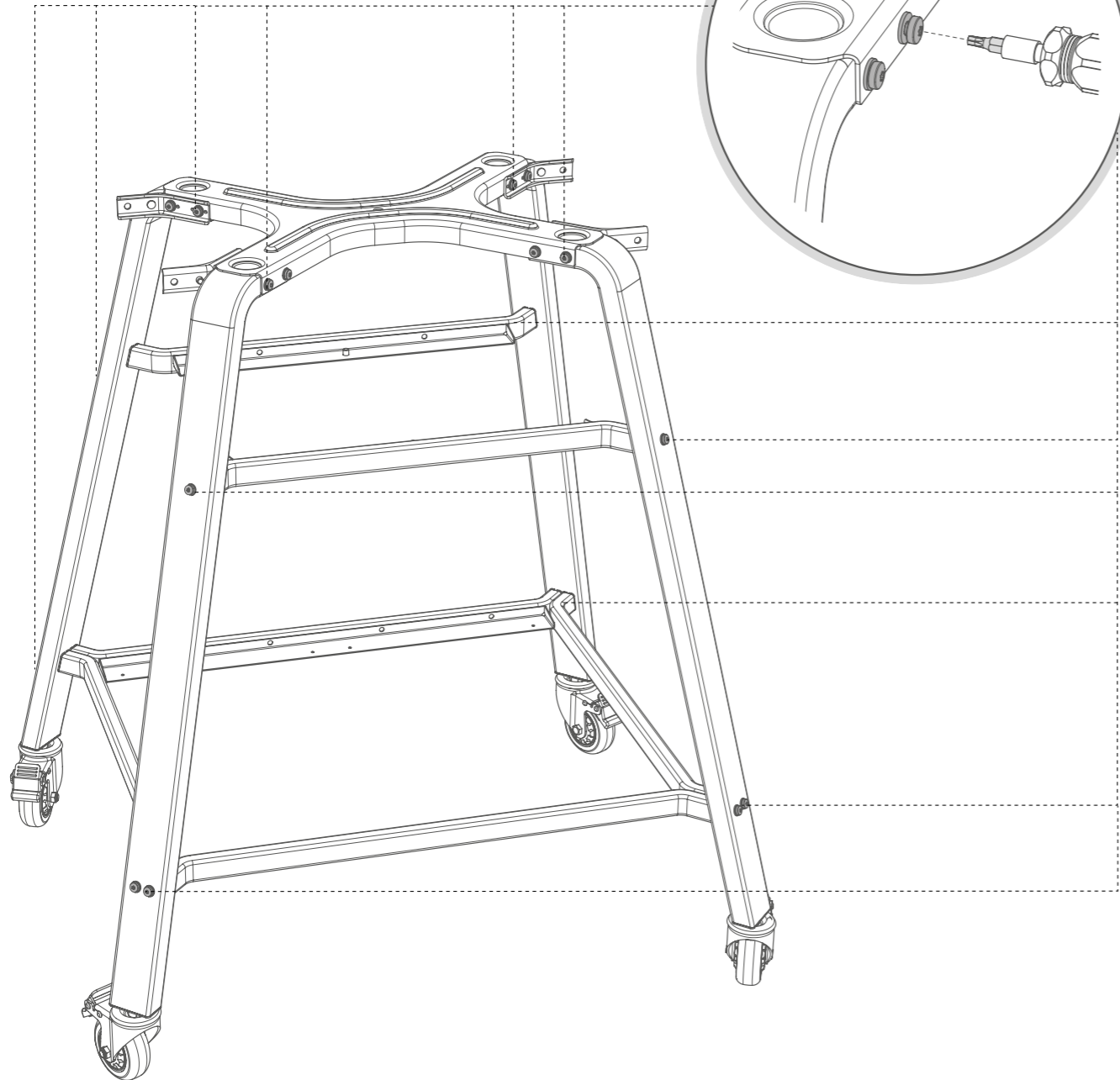

## TIGHTEN BOLTS

Tighten all fixings on the stand, being careful not to over tighten.

# Step 10

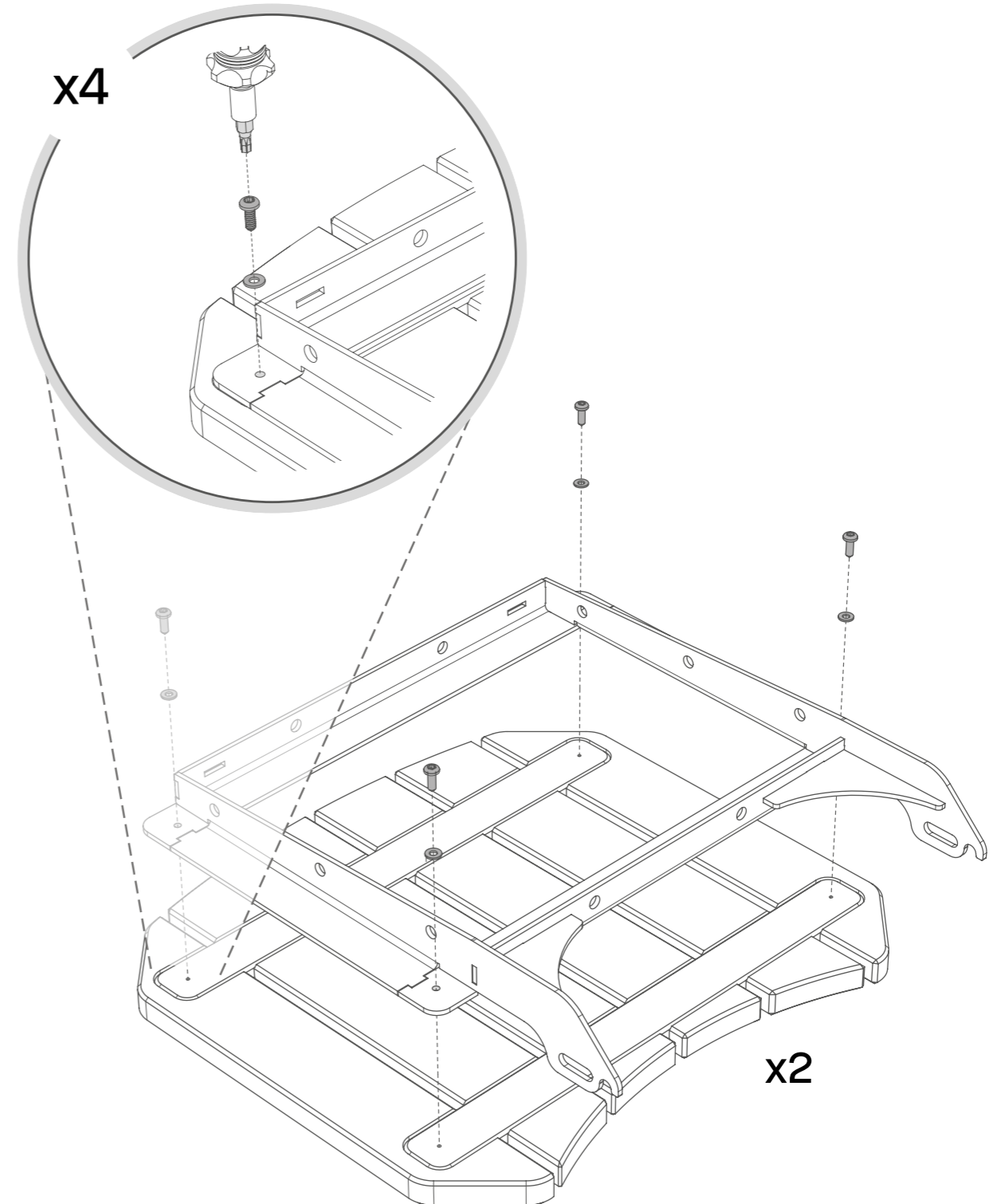
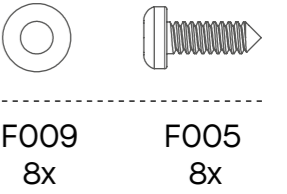

# Step 11

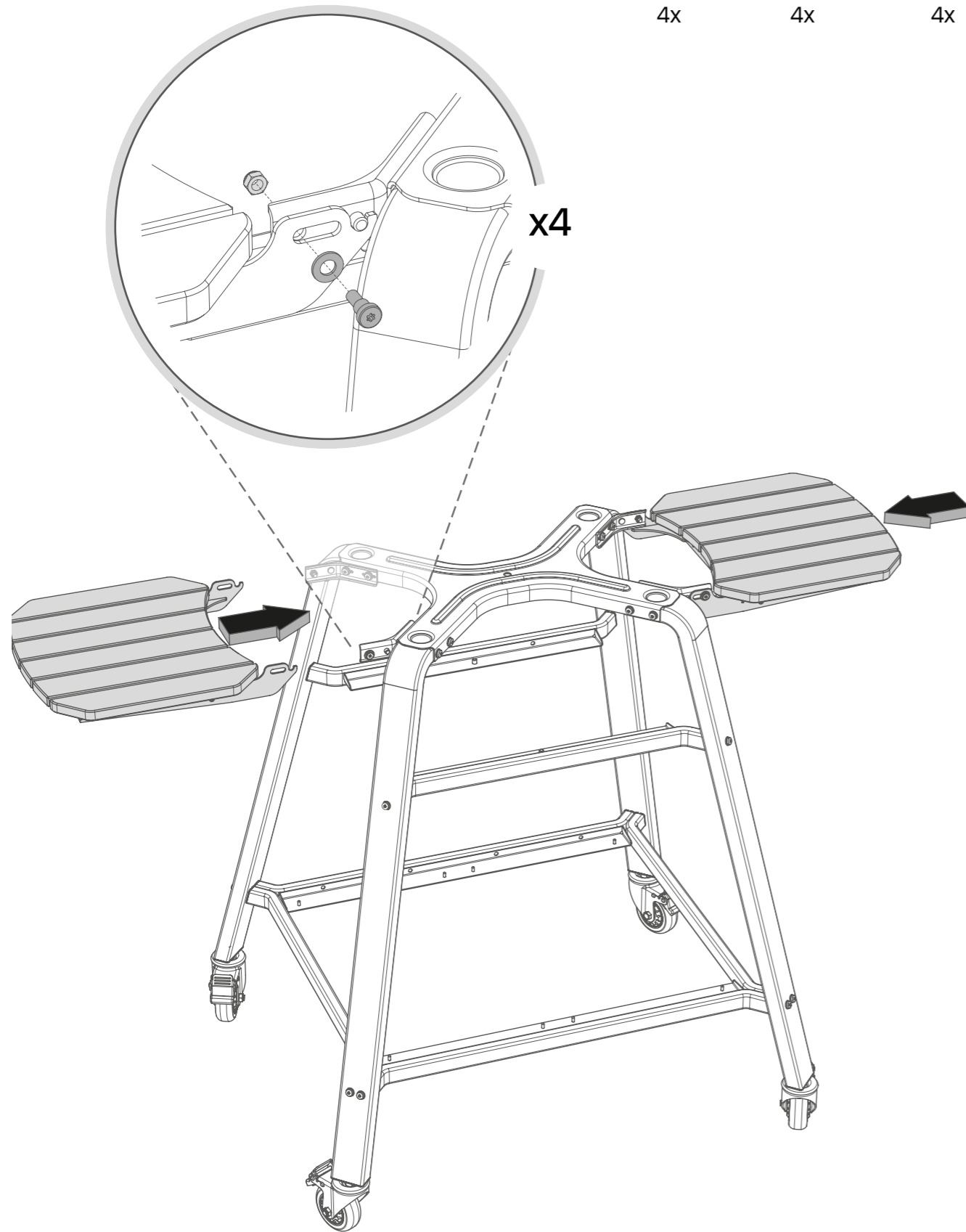
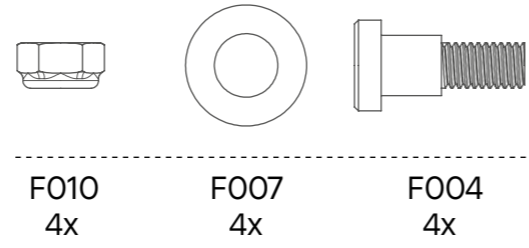

# Step 12

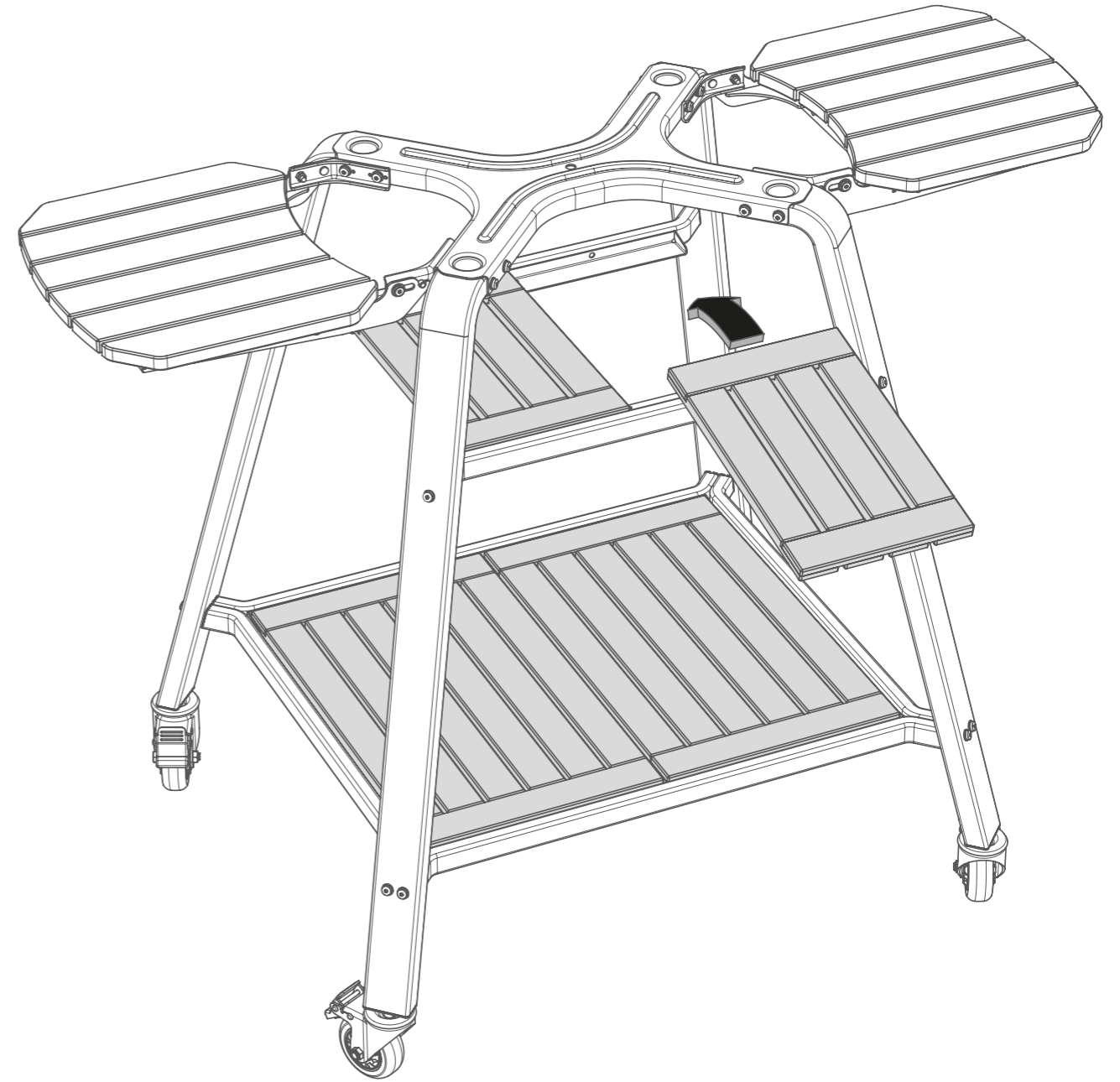

## Step 13

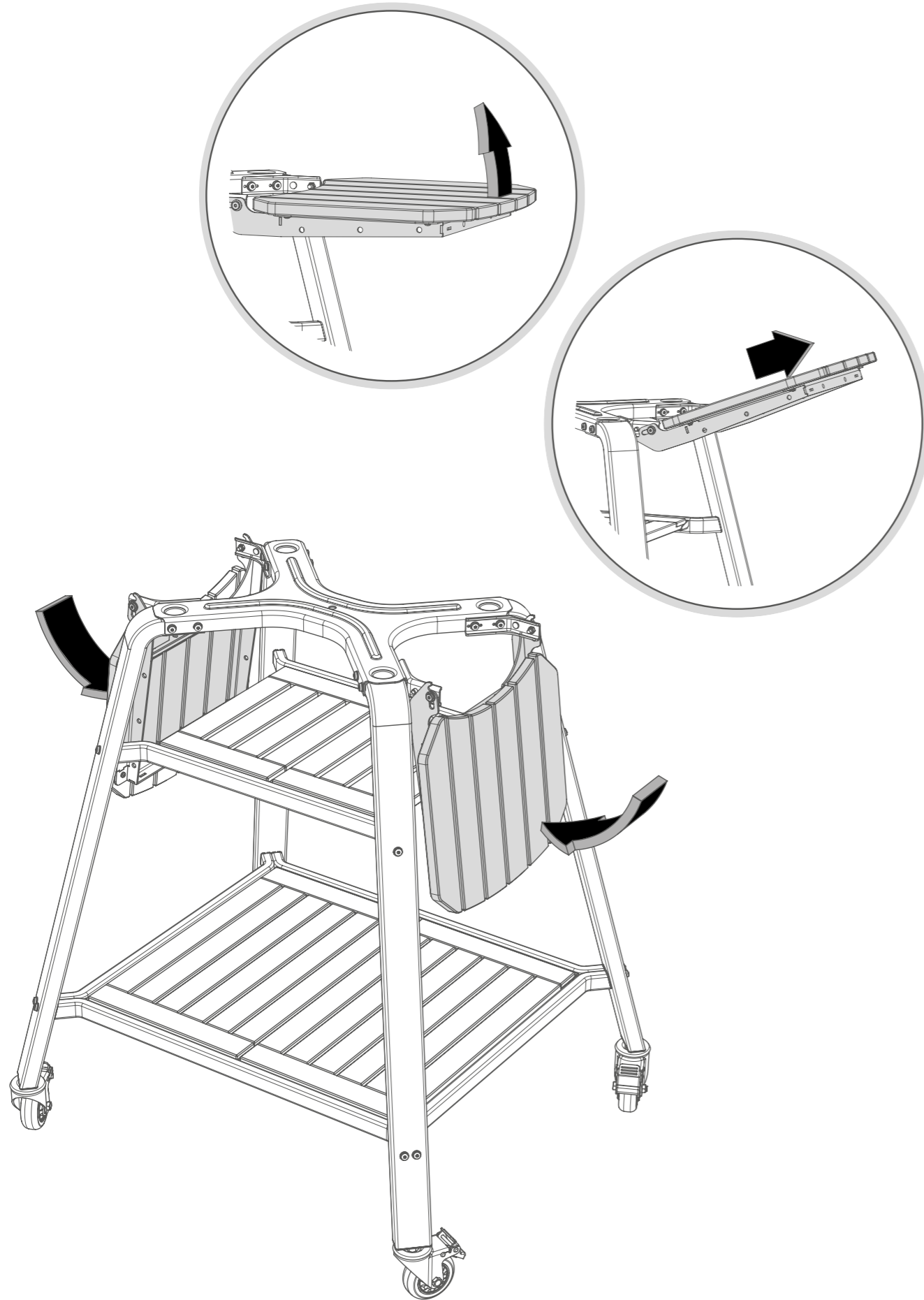

## Step 14

### INSTALLING DOME

Ensure fixing F006 is in place on the stand before installing the oven.

Remove anything loose from the oven before moving.

Two people should pick up Dome from the rounded ends of the oven as shown.

Don't use the mouth of the oven as lifting point.



F006  
1x

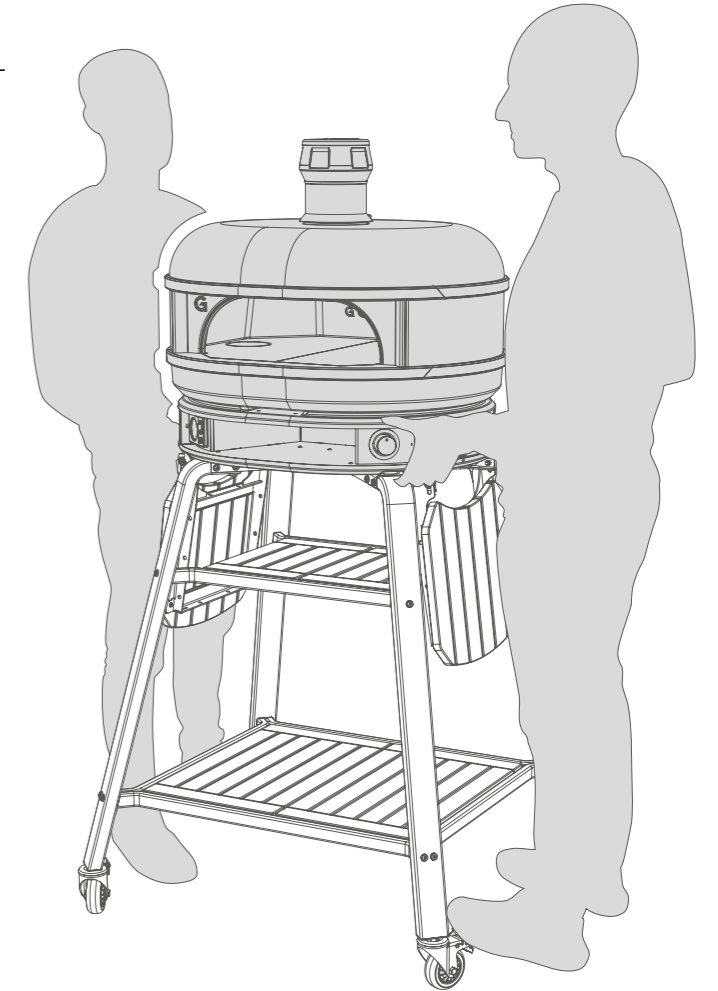

Align Dome's feet with the highlighted slots. Ensure the feet are fully aligned before moving on.

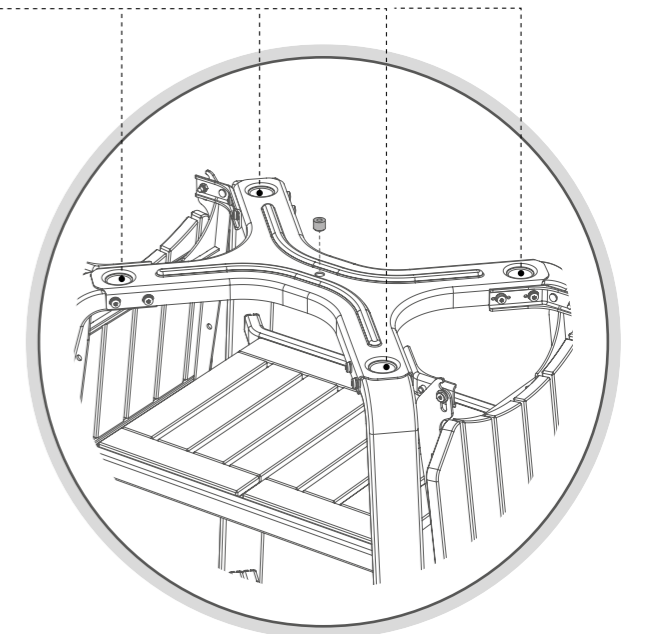

# Step 15

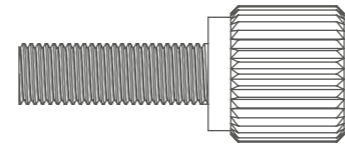

F003  
1x

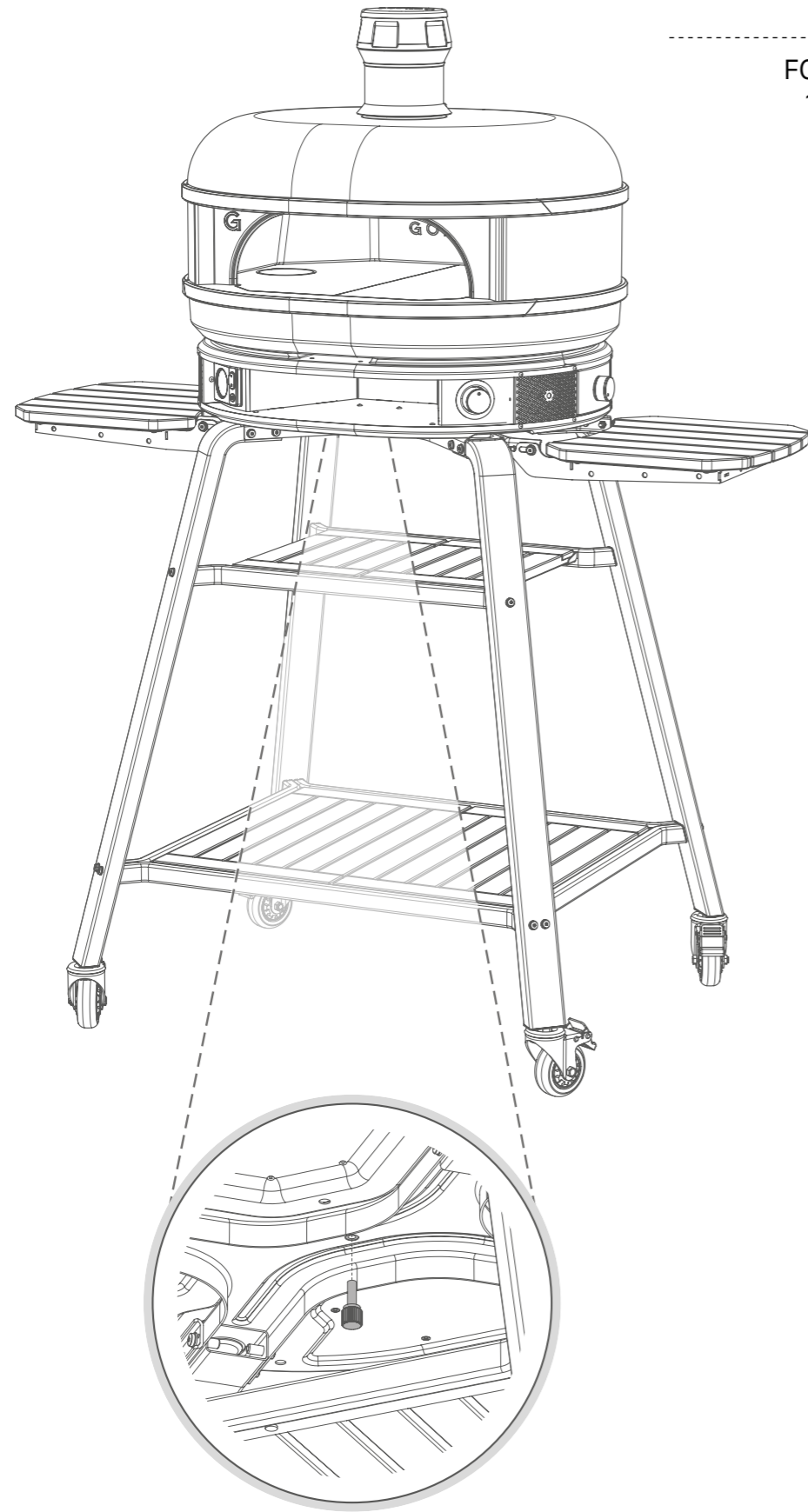

**GOZNEY°**