

**Please thoroughly read the entire instructions before laying the floor. If gluing the flooring to a subfloor, see separate glue-down instructions.**



### **Caution: Wood Dust**

**Drilling, sawing, sanding or machining wood products can expose you to wood dust, a substance known to the State of California to cause cancer. Avoid inhaling wood dust or use a dust mask or other safeguards for personal protection. For more information, go to: [www.P65Warnings.ca.gov/wood](http://www.P65Warnings.ca.gov/wood).**

**Precautionary Measures:** Equipment should be equipped with a dust collector to reduce airborne wood dust. Wear an appropriate NIOSH designated dust mask to reduce exposure to airborne wood dust. Avoid contact with eyes and skin. In case of irritation, flush eyes or skin with water for at least 15 minutes. In cases of severe irritation or discomfort, seek immediate medical attention.

### **Installer/Owner Responsibility**

It is **extremely important** that you read and understand this information completely prior to starting, since **improper installation can void the warranties.**

It is the responsibility of the installer, and owner, to ensure that the job site environment, sub-floor and subsurface conditions involved meet or exceed all requirements as outlined in these installation instructions. Manufacturer declines all responsibility for product performance or installation failure due these environmental conditions not being met.

Carefully inspect **ALL** material prior to installation for defects. Material installed with visible defects is not covered under warranty. Flooring is manufactured in accordance with industry standards, which allows manufacturing and natural deficiency tolerances up to 5% of the total installation. Examine the flooring for color, finish, and style **before installation** to insure you have the correct product.

Wood is a natural product that can vary in color, grain, and contains natural characteristics that varies plank to plank and is to be expected. We do not warrant against these natural variations from plank to plank. If not satisfied with the flooring prior to installation, contact your dealer- **DO NOT INSTALL** the flooring. Accepting or rejecting the material must be done prior to installation. **Flooring warranties DO**

**NOT cover materials with visible defects once they are installed.**

### **Tools & Equipment Needed:**

Safety Glasses	NIOSH approved Dust Mask
Tape Measure	Vacuum Cleaner
Sliding Miter Saw	Carbide or Diamond Saw Blade
Pencil	Spacers / Wedges
Handsaw	Jigsaw
Wood Glue	Utility Knife
Oscillating Multi-tool	Hand Planer
Acoustical Underlayment	
Possibly a Vapor Barrier	

### **Pre-Installation & Jobsite Conditions**

- Transport and store the cartons horizontally in a dry, well-ventilated area.
- During storage and installation, maintain a room temperature of at least 64° F (18° C). Spread the cartons out so that they acclimate to the minimum required room temperature.
- Maverick Flooring can be installed over most hard surfaces including resilient floor coverings such as LVT, SPC, VCT, linoleum or stone provided they are glued down, sufficiently fixed, completely flat and have no loose areas. (**DO NOT INSTALL OVER CARPET OR SOFT SURFACE**)
- Maverick can be installed in all indoor areas and in most commercial areas, except it is not suitable for installation in humid/wet areas (bathrooms, saunas, etc.)
- Never install very heavy pieces of furniture such as kitchen islands/cabinets on top of the flooring.

### **Subfloor Preparation**

- **Subfloor:**  
Ensure that subfloor is flat, dry, firm and clean. Any deflection in the subfloor greater than 1/8" over 6' length should be either smoothed with patching or leveling compound or ground/sanded down mechanically.
  - Wood subfloors must have a moisture content (MC) less than 13% at 68°F.

- **Acoustical Underlayment:**  
OmniChoice Universal is the recommended acoustical underlayment for all Maverick floating installations. It has been tested so that the cushion provided is enough to reduce sound but not too much cushion to separate the joints. Although not required, it is highly recommended to reduce sound transmission when the floor is walked on.
- **Moisture Barrier:**  
OmniChoice Vapor Bloc is the recommended vapor barrier for all Maverick floating installations. A vapor barrier is required for Maverick when the subfloor is:
  1. Concrete. With or without under-floor heating system.
  2. A lightweight concrete subfloor.
  3. A wooden subfloor with an under-floor heating system.
  4. Ceramic tile or stone that is adhered to a concrete subfloor.
 OmniChoice Vapor Bloc is recommended as it serves as both a vapor barrier and acoustical underlayment all in one. The Vapor Bloc installation is warranted up to 10 lbs. Calcium Chloride (ASTM F1869) or 90% insitu-RH (ASTM F2170).

## Pre-Installation Instructions

**Inspect the Flooring:** Inspect material for color, finish, milling, and grade. Cull out any damaged pieces.

**Remove all skirting boards / base molding.**

**Undercut Door Casings:** Undercut all door casings 1/16" higher than the thickness of the flooring being installed. To do this use the height of a scrap piece of material plus the underlayment as a guide. Lay the flooring and underlay flat on the subfloor and cut the casing with a handsaw, oscillating multi-tool or a power jamb saw.

**Blending the Cartons:** To achieve a uniform appearance across the entire floor, we recommend that you open and work from several cartons at a time and dry-lay the floor, mixing the planks from several cartons.

**Expansion Space (Floating):** Please follow the following expansion gap chart:

- Up to 15 linear feet (225sqft): ¼" expansion
- 15 Linear feet (225sqft) to 50 Linear Feet (2500 sqft): Add 1/16" for each additional 5 ft (25 sqft) over the original 225 sqft (example ¼" + 1/16")
- 50 linear feet plus (2500 sqft+) minimum of 1" expansion

**Room Measurement:** measure room to calculate number of rows, allowing for a minimum of 2" of plank width on the 1<sup>st</sup> and last row. Maximum area is 6724 sqft (625 m2), or 25 Linear meters (82 linear ft) in either direction before an expansion joint transition is required.

## Floating Floor Installation

This product is a 45° long side angle application with a 5G® Fold Down short side click system. Allowing for easy installation- Simply press together short edge.

The floor should always be laid in the longitudinal direction of the room. If the room is roughly square, you can choose the direction of the floor.

Please watch: [www.valinge.se/products/click-flooring-technology](http://www.valinge.se/products/click-flooring-technology)

### STEP 1

Start by removing/sawing off door liners/frames so that the floor can be pushed underneath which gives a neat and professional result. The easiest way is to use an oscillating multi-tool or a handsaw. Use a piece of Maverick flooring turned upside down along with the underlayment as a template to get the desired height. Remember not to lock the flooring against or under the door frame.

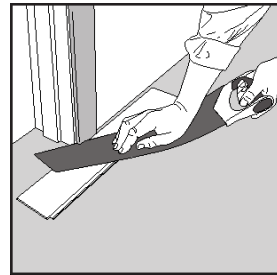

### STEP 2

First plank, first row. Start in a left corner and place the first board's underlip out towards the room on both the long and short side. Place a wedge between the short edge of the plank and wall to allow for the required expansion spacing. After 3 rows, you can easily position the flooring against the front wall with required spacers.

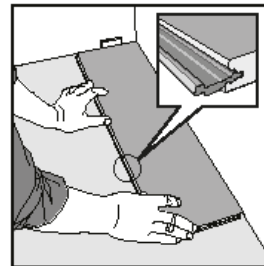

### STEP 3

The next board is placed with the short end against the first board's short end. Make sure the planks are tight against each other. Press the short end down so that it clicks into place. Continue in the same way along the entire first row.

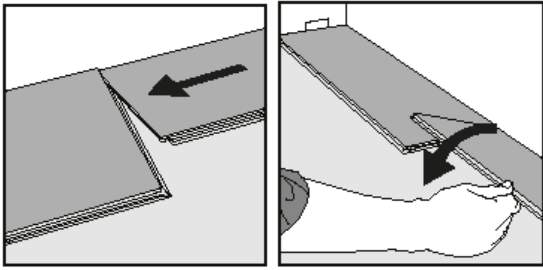

### STEP 4

Cut the last board in the first row to the correct length. Do not forget the expansion gap around the floor.

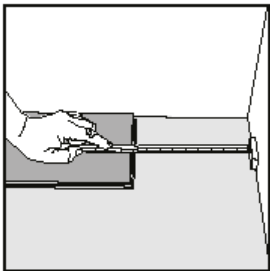

### STEP 5

Start the next row with the piece left over from the previous row. The short ends in adjacent rows must be separated with at least 16" (400mm) on boards above 59" (1500mm) long. Boards shorter than 59" (1500mm) shall have a short end separation of a least 12" (300mm).



### STEP 6

Second plank, second row. Place the plank gently and tight to the short end of the previous plank. Fold down the plank in a single movement making sure short ends are tight together. You should hear a click as the short end locking system engages. *Be careful when placing the boards together so that nothing is damaged. Make sure you do not have any debris such as sawdust in the joint, as this can prevent or damage the board if it is forced together.* Continue laying the remaining rows in the same way.

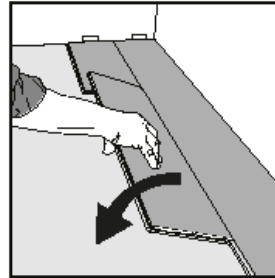

### STEP 7

After 2-3 rows, adjust the distance to the front wall by placing wedges to create the required expansion spacing. When the floor is finished remove the wedges.

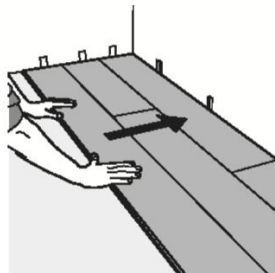

### STEP 8

The first row of boards may require an adjustment due to an uneven starting wall. Draw the contour of the wall on the boards. Then loosen the boards in the first row by grabbing the long side, pulling upwards and at the same time hitting the joint lightly. Cut on the line and reinstall. For best results it is sometimes necessary to split the first board so that the first and last board end up around the same width to avoid that the last board becomes too narrow.

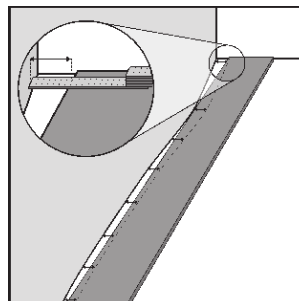

### STEP 9

Remember that last row must have a plank width of at least 2". Allow for required expansion spacing at wall. Sometimes you may have to use a board puller or crowbar to get the last row into place.

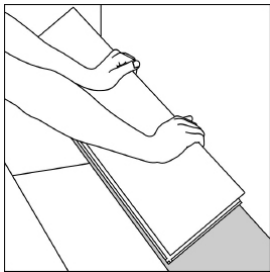

### STEP 10

For pipes, holes are drilled in the board which must be at least 3/4" (20mm) larger in diameter than the pipe. Saw as shown in the picture. Glue the cut piece again. Remove excess glue immediately. Cover the holes with pipe sleeves.

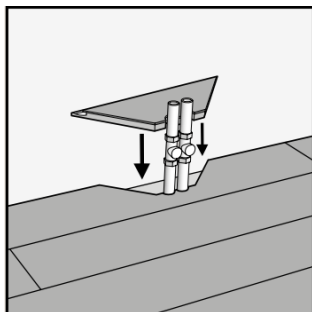

### STEP 11

If you can't angle in a board underneath door linings or sills use the following procedure. Cut/plane away the top of the locking joint with a chisel or small hand planer. Glue on the bottom lip with a wood adhesive and lay the board in place. Use wedges to press the board into place while the glue dries.

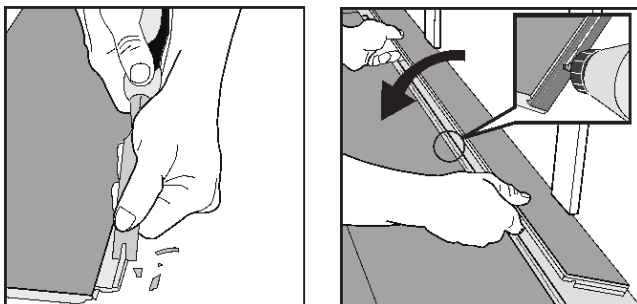

### STEP 12

If you need to pick up a laid board, the easiest is to use the 5G removal tool. You push the tool into the joint on the short side, so that the locking releases. With this tool you can remove single boards without loosening the whole board.

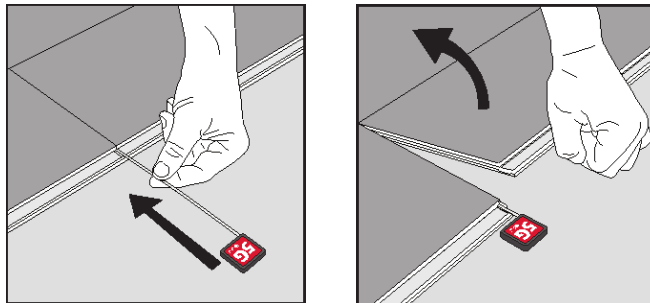

### STEP 13

If you do not have this tool and need to pick up a board after laying, you can angle up a whole board row along the long side at a time. Dismantle the short sides by pushing them apart horizontally. It is also possible to angle up the short side of the end joints.

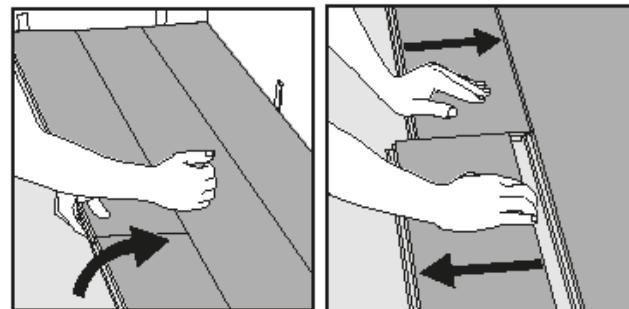

**Final Touches:** Remove expansion spacers / wedges from around edges of install. Trim any excess underlayment and install or re-install any transition pieces, reducer strips, T-moldings, thresholds, bases and/or quarter round moldings.

**Floor Cover:** The basic rule is that the wooden floor should be laid last in the construction process to avoid damage. If further work is to be done in the room where the floor has been laid, the floor should be protected with a material that allows moisture to pass through (e.g. Ram Board). Also check that the cover does not discolor the floor or leave residues such as wax. When taping paper or sheets together, tape them to each other, not to the floor. Many tapes adhere so hard to the floor surface that the coating detaches when the tape is removed. The longer the tape is left in place, the greater the risk that it will stick harder to the finish.

### **Radiant Heat Application (Only Floating Application)**

Maverick Flooring can be installed on water based or electrical floor heating systems.

- The floor heating system must be on a flat surface and well distributed across the floor.
- Both a room sensor (thermostat) and a floor sensor (for max. temp limitation) must be installed to prevent the surface temperature from exceeding 27°C (80°F).
- Floor heating must never be installed under kitchen cabinets or similar installations
- Water based systems with pipes positioned in profiled particle fiberboards with heat distributing aluminum sheets must be covered with loadbearing profiled (ie tongue & groove) sheet of particleboard or HDF, in at least 8mm thickness.
- With all heating systems, a vapor barrier (PE Foil .2mm) must be placed between floor heating system and the underlay material with any type of subfloor.

For more information about floor heating in buildings, please read: NWFA Guidelines on Radiant Heat Standards

NWFA.org

### **Care and Maintenance**

- Routine, regular maintenance, daily if necessary, should include sweeping, vacuuming and occasionally cleaning with Bona Pro Series Hardwood Floor cleaner and microfiber cleaning pads. Walking on a dusty or dirty floor is the fastest way to damage the finish.
- Place a rug or mat outside and inside the front entranceway to help remove excess dirt/grit/sand and moisture from foot traffic. This will help prevent damage to the flooring finish.
- Any rugs or mats must be made of a breathable material and non-marking rubber to prevent moisture entrapment and finish discoloration.
- Never use excessive amounts of water for cleaning. Never pour any cleaner directly onto flooring.
- Use fabric-faced glides or large (at least 2" in diameter), broad surfaced (at least ¾" in width), barrel-type, double wheel casters (non-marking rubber or polyurethane) on chairs and furniture legs to prevent scratching, scuffing and other damage.
- Try to wipe up spills immediately.
- Stains – *Food/Water/Pet Urine/Spills*. Immediately absorb spilled foods and liquids with cloth rags or sponges. Use Bona Pro Series Hardwood Floor Cleaner with cloth or sponge to finish clean up.
- Stains – *Grease/Tar/Oil/Rubber Scuff Marks/Lipstick/Crayon/Markers*. Use the method above. If material remains, try mineral spirits on a white cloth. Follow with Bona Pro Series Harwood Floor Cleaner.
- *Gum*. Apply a plastic bag filled with ice on top of the gum until it is brittle enough to crumble off. Clean area with Bona Pro Series Harwood Floor Cleaner.