

FURRIONNET-ZERO

Solar Charge Controller Mounting Bracket

Installation Guide



Model:
FSCC60PWM-BL



* To view the multi-language user manual, please access the link or scan the QR code.

* Pour obtenir le manuel d'utilisateur multilingue, accédez au lien ou scannez le QR code.

* Para ver el manual de usuario en otros idiomas, acceda al siguiente enlace o escanee el código QR.

<https://furrion.com/pages/downloads-power-distribution>

Please read this quick start guide and follow the steps carefully. This quick start guide will help you to install the device properly and avoid improper usage.

Features

- High current connectors.
- Allows for pre-installation of cables for solar panel and battery connection.
- Compatible with Furrion MPPT Solar Charge Controllers (models FSCC30PW and FSCC60PW).
- Easy to install Furrion MPPT Solar Charge Controller.

What's in the Box

Make sure you have the following items included in the packaging. If any items are damaged or missing, contact your dealer.

Item	Description	Quantity
1	Solar Charger Mounting Bracket	1
2	Flat head screw (ST4.2*19mm)	4

Wire and Cable Size

The wiring and installation methods must conform to all national and local electrical code requirements, and need to follow RVIA regulations.

PV Wire Size

Since the PV outputs can vary due to the array connection method, the minimum wire size must be in accordance with the maximum array short-circuit current. The PV array is suggested to be connected in series.

Please use PV Photovoltaic wire, the reference size as below:

PV short circuit current	Wire Gauge	Maximum Wire Length
10A	12AWG	30FT

NOTE: The PV wire size listed is only for reference. If there is a long distance between the PV array and the controller, larger wires can be used to reduce the voltage drop and improve performance.

Battery Cable Size

The battery cable size must conform to the rated current, the reference size as below:

Model	FSCC30PW-BL	FSCC60PW-BL
Maximum charge current	25A	50A
Cable Gauge	10AWG	6AWG
Maximum Cable Length	15FT	15FT

NOTE: The cable size is only for reference. If there is a long distance between the controller and the battery, larger cables can be used to reduce the voltage drop and improve performance.

Installation

1. Connect the solar panel and battery to the solar charger mounting bracket.
- Loosen the positive (+) and negative (-) terminal screws of the solar ports.
- Feed the solar cables into the ports. Red wire to positive (+), black wire to negative (-).
- Tighten the screws until secured. The torque force for the screw should be 25lbs-inch for 10AWG wire, 30lbs-inch for 8AWG wire, and 35lbs-inch for 6AWG wire.

- Repeat the steps above to connect the battery to the solar charger mounting bracket.

NOTE:

- An inline fuse can be installed to the positive wire between the rooftop solar electrical box and the mounting bracket of solar charge controller.
- An inline fuse can be installed to the positive wire between the battery and the mounting bracket of solar charge controller.
- The rating of the fuse is determined by the maximum input rating of the solar panel, or output of the controller.
- A DC breaker is recommended to be installed between the solar input and the mounting bracket of solar charge controller.
- The rating of the switch is determined by the maximum input rating of the solar panel, or output of the solar charge controller.
- Based on the current of the MPPT charger you purchased, connect the battery to the corresponding 25A or 50A charging port.

NOTE: If the battery cable is connected to the 50A port by RV manufacturer, a 25A MPPT

controller will work without moving the wiring to the 25A port.

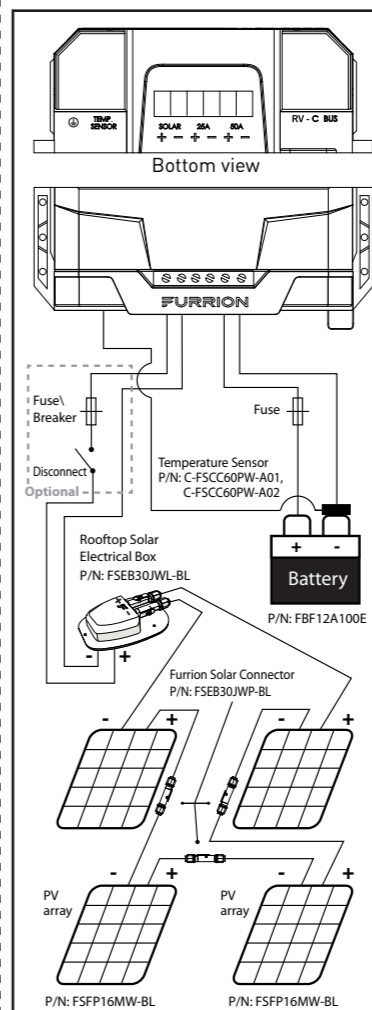
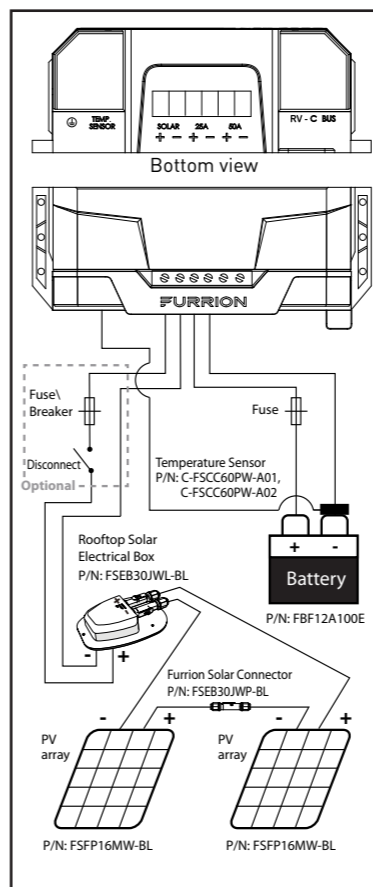
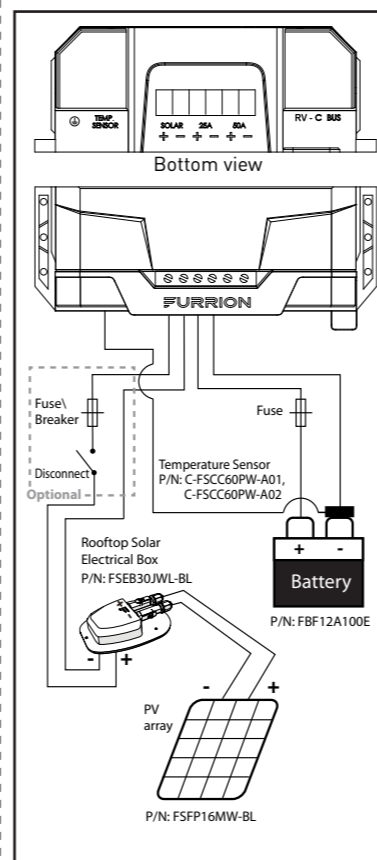

2. Choose an appropriate mounting position and attach the solar charger mounting bracket on the wall using four self-tapping screws.
3. The bracket needs to be installed with enough space above it to allow for clearance of the controller.

Top: 17"
Left and Right Sides: 8"

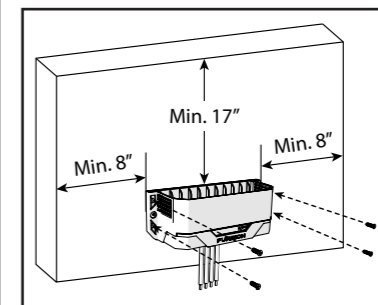

FURRION

Furrion Innovation Center & Institute of Technology

● 52567 Independence Ct., Elkhart, IN 46514, USA ● Toll free: 1-800-789-3341
● Email: support@furrion.com

©2007-2021 Furrion Ltd. Furrion® and the Furrion logo are trademarks licensed for use by Furrion Ltd. and registered in the U.S. and other countries.

For Patent Info: www.furrion.com/pages/patents

FURRION.COM

IG-FEN00001 V6.0