

KAM

INSTRUCTION MANUAL

Derby 8 Laser Light

KML403

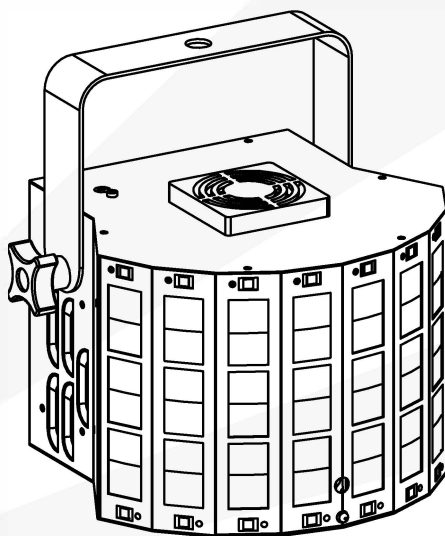

Version 1.0



Unpacking Instructions

Read Manual before Operation

Before operating this device, please read this manual thoroughly, and retain it for future reference.

Warning Data

Please note the warnings in bold which will ensure the safe and smooth operation. These warnings are important to a certain extent.



Attention! Indicates a skill or other useful information for special situations.



Important! Indicates important information to protect personnel from laser incident or injury.



Caution! Prevent damage or injury from incorrect operation.

Warning!

Shields, lenses or ultraviolet screens shall be changed if they have become visibly damaged to such an extent that their effectiveness is impaired, for example by cracks or deep scratches. The lamps should be changed if they have become damaged or thermally deformed.

Unpacking Instructions

Carefully unpacking the carton, checking contents to ensure that all parts are in good condition. Inform the shipper immediately and retaining packing material for inspection if any parts are damaged from shipping or the device is damaged. Keeping packing materials as evidence for shipper's confirmation.



Attention!

This unit is in perfect condition before delivery, please check all accessories when unpacking the unit. User should follow this user manual to operate this unit, and make sure that you are clear on all laser safety information and unit operation before power it on. Any wrong operation will make this unit out of warranty.

Carefully moving after receiving it, checking whether there is any damage from shipping, and all the accessories in it.

NAME	QTY
LED system	1
Power Cord	1
User manual	1
Packing Case	1

Safety Instructions

Safety Instructions

- ♻️ To protect the environment, please try to recycle the packing material as much as possible.
- 🏠 The projector is for indoor use only, IP20. Use only in dry locations. Keep this device away from rain and moisture, excessive heat, humidity and dust. Do not allow contact with water or any other fluids, or metallic objects
- 🗑️ Don't throw this product away just as general trash, please deal with the product follow the abandon electronic product regulation in your country.
- 📍 Locate the fixture in a well ventilated spot, away from any flammable materials and/or liquids. The fixture must be fixed at least 20cm from surrounding walls
 - ◆ To avoid condensation to be formed inside, allow this unit to adapt to the surrounding temperatures when bringing it into a warm room after transport. Condensation sometimes prevents the unit from working at full performance or may even cause damages
 - ◆ Don't cover any ventilation openings as this may result in overheating.
 - ◆ Don't install it on flammable object.
 - ◆ Do not use it when maximum ambient temperature is higher than 40 degree,
 - ◆ Unplug the unit when it is not used for a longer time or before replacing the bulb.
 - ◆ Don't open the top cover to avoid unit damage.
 - ◆ Please use the original packing when the device is to be transported.

⚠️ **Never expose the lens to direct sunlight, even for a short period, This may damage the light effect or even cause fire!**

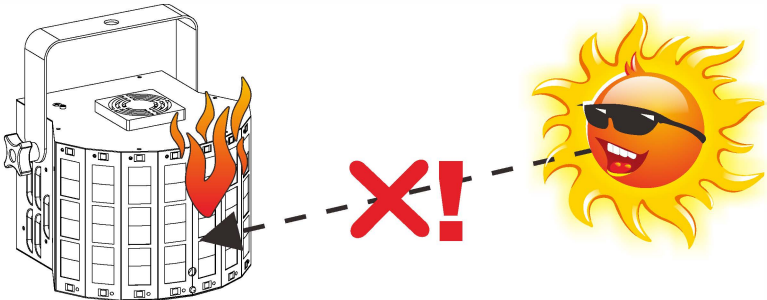

Safety Warnings

- ◆ Always connect the product to a grounded circuit to avoid the risk of electrocution.
- ◆ Always disconnect the product from the power source before cleaning or replacing the fuse.
- ◆ Avoid direct eye exposure to the light source while the product is on.
- ◆ Make sure the power cord is not crimped or damaged.
- ◆ Never disconnect the product from power by pulling or tugging on the cord.
- ◆ If mounting the product overhead, always secure to a fastening device using a safety cable.
- ◆ Make sure there are no flammable materials close to the product when operating.
- ◆ Do not touch the product's housing when operating because it may be very hot.

📖 Keep this User Manual for future use. If you sell the product to another user, be sure to give this document to the next owner.

Overhead Rigging

 **Attention!** The installation must be carried out by qualified service personal only. Improper installation can result in serious injuries and /or damage to property. Overhead rigging required extensive experience! Working load limits should be respected, Certified installation materials should be used, the installed device should be inspected regularly for safety.

- ◆ Make sure the area below the installation place is free from unwanted persons during rigging, de-rigging and servicing.
- ◆ Locate the fixture in a well ventilated spot, far away from any flammable materials and/or liquids. The fixture must be fixed at least 20cm from surrounding walls
- ◆ The device should be installed out of reach of people and outside areas where persons may walk by or be seated.
- ◆ The device should be well fixed; a free swinging mounting is dangerous and may not be considered!
- ◆ Do not cover any ventilation opening as this may result in overheating
- ◆ Before the first time use, it must be inspected by professional staff to make sure safety, inspection regularly every year.

 Before rigging make sure that installation area can hold the 10 times weight of device. Using the steel rope which can hold 12 times weight of device, through the eye-bolt for assisting hang installment.

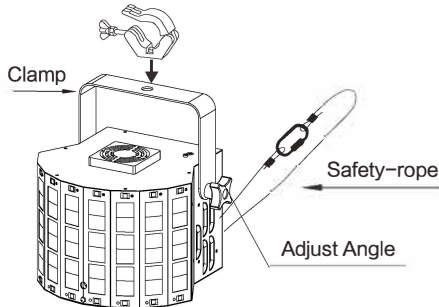

AC Power

Please use the included power cable, note that power voltage and frequency are the same as the marked voltage and frequency of device when connecting power. Every device' s power should be connected separately, so that device can be controlled individually.

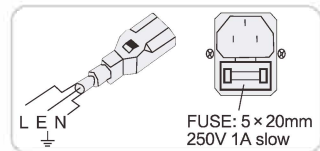

Cable spec. :

Cable(EU)	Cable(US)	Pin	International
Brown	Black	Live	L
Light blue	White	Neutral	N
Yellow/Green	Yellow/Green	Earth	

Product Installation/Product Dimensions

DMX-512 connection

- ◆ Connection between laser lights and DMX must use the shielded cable of a diameter more than 0.5mm. Please use the attached 3 pin XLR plug/socket to connect the DMX output/input interface. The connection between socket and cable as below (note the plug/socket's 3 pin number and position).

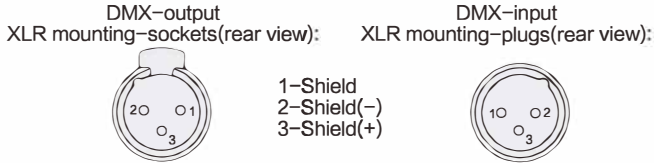

- ◆ Note, XLR plug/socket's 3pin can not be touched by inner hull, connection between pins is not allowed. Except above connection, XLR plug/socket can not be connected with XLR control line. Device receives international standard DMX512(1990) control signal.
- ◆ When using standard DMX512 control signal, the last device's output interface must be connected to a DMX plug. This plug is putting a 120 ohm resistance between "canon" plug's 2 pin and 3 pin. Showing as below pic. Sticking this plug into the last device's signal output interface, it will avoid the interference during the process of signal transmission.

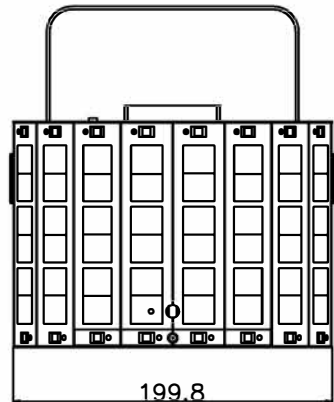
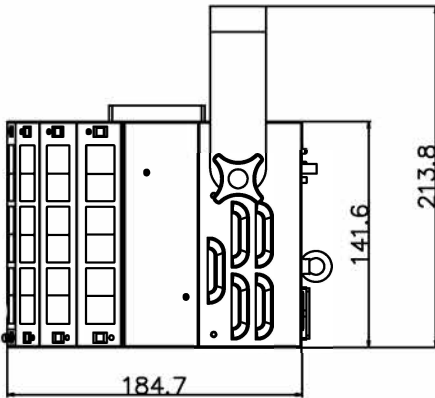

Operation instructions /Product Parameter

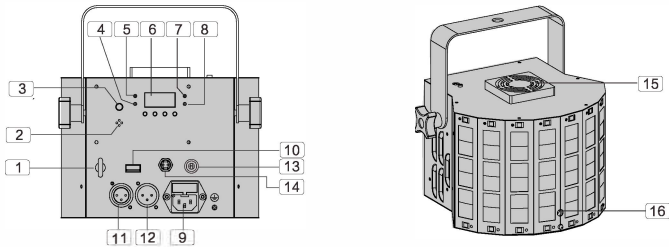

NO	Name	FUNCTION
1	Insurance rings	Connecting wire rope to prevent illegal operation and fall
2	Microphones	Receiving the audio signal through a microphone, and positive response to the intensity by the potentiometer
3	Sound sensitivity	Changing sound sensitivity by potentiometer
4	AUTO indicator	In Auto model, blue indicate light on.
5	DMX indicator	In DMX model, red indicate light on after DMX connected,
6	LED display	For setting model
7	SLAVE indicatory	In slave model, yellow indicate light on
8	MUSIC indicator	In sound model, green indicate light on
9	Power input	Power input socket, built-in protective tube and spare tube
10	USB-F Interface	For USB wireless DMX dongle. Don't use this connector for connection with a PC
11	DMX output	3PIN female XLR interface, for DMX communication
12	DMX input	3PIN male XLR interface, for DMX communication
13	Key switch	Key switch Make sure the professional person use
14	Remote switch	Switch off the laser manually if error occurs
15	Cooling fan	Cooling and never cover this fan outlet
16	Laser output	(Laser class 3R). DO NOT look directly into the laser beam.Risk of injury and blinding

Specifications

Model	KML 403
Size	199.8 x 184.7x 213.8 mm
Weight	1.95kg
Power	46W MAX
Voltage	100-240V 50/60Hz
Strobe LED	0.5W*16pcs RGB
Laser power rate	Class 3R Laser
Laser power	100mW/650nm 30mW/532nm
Red LED	6W*1pcs
Green LED	6W*1pcs
Blue LED	6W*1pcs
White LED	6W*1pcs
DMX channels	2/9
Auto	7
Sound	7

Menu operating instruction

Once after every power on laser, the VERSION and MANUFACTURE INFORMATION will be shown in LED monitor of rear panel. When laser is powered on, LED monitor on rear panel shows the current operating standalone mode or DMX address of DMX mode. With help of LCD control panel, is very easy to set and change the operating mode of laser. After every resetting and saved, the new mode information will be shown on LED monitor at next power.

MENU Model choice or back to the last function.

ENTER Confirm, enter into the deeper menu. Press it to save the chosen model or DMX initial add.

UP **DOWN** For changing DMX initial add or function value

KML403

MENU

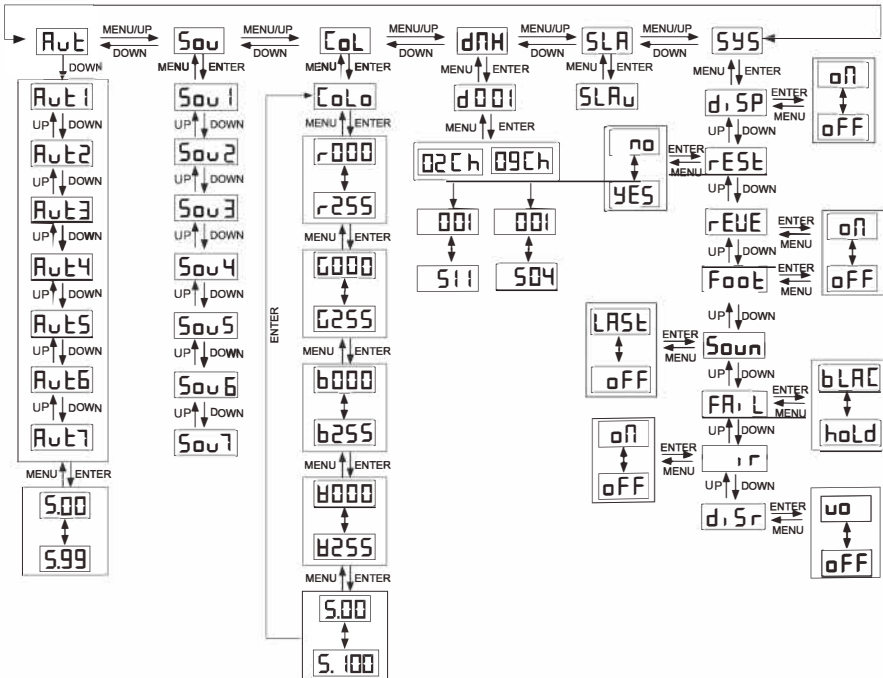

Function instructions

FUNC	MENU 1	MENU 2	MENU 3	MENU 4	MENU 5	manual
Aut	Aut 1	S.01-S.99				Auto_Par&Strobe&Laser
	Aut 2	S.01-S.99				Auto_Par&Strobe
	Aut 3	S.01-S.99				Auto_Par&Laser
	Aut 4	S.01-S.99				Auto_Strobe&Laser
	Aut 5	S.01-S.99				Auto_Par
	Aut 6	S.01-S.99				Auto_Strobe
	Aut 7	S.01-S.99				Auto_Laser
Sou	Sou 1					Sound_Par&Strobe&Laser
	Sou 2					Sound_Par&Strobe
	Sou 3					Sound_Par&Laser
	Sou 4					Sound_Strobe&Laser
	Sou 5					Sound_Par
	Sou 6					Sound_Strobe
	Sou 7					Sound_Laser
Col	R000-R255	G000-G255	B000-B255	W000-W255	F.00-F.99	Color Mode,S:**: Par strobe speed F.00 bright light, F.9 the fastest speed
DMX	d***	2CH	d**1-d511			DMX
		9CH	d**1-d504			
Sla	Slav					M/S
SYS	Leds	ON				power saving mode open
		OFF				power saving mode close
	Test					Test mode
	Rest					system initialization



Note: In sound model, device will close light in 5 seconds automatically, if there isn't any sound signal.
Light on until sound signal received.

DMX operation instructions

DMX Channels Chart



This device adopts large storage and high speed chip, and has lots of effects based on laser light DMX application. There are many kinds of functions in channel one.

2 channel mode

chanel	value	function
1	000-009	Black out
	010-044	Par & Strobe & Laser
	045-079	Par & Strobe
	080-114	Par & Laser
	115-149	Strobe & Laser
	150-184	Par
	185-219	Laser
	220-255	Strobe
2	000-250	speed
	251-255	Sound

DMX operation instructions

9 channel mode

channel	value	function
1	000-009	Black out
	010-044	Par & Strobe & Laser
	045-079	Par & Strobe
	080-114	Par & Laser
	115-149	Strobe & Laser
	150-184	Par
	185-219	Laser
	220-255	Strobe
2	000-250	speed
	251-255	Sound
1CH in 000-009 value		
3	000-005	No function
	006-020	Red
	021-035	Green
	036-050	Blue
	051-065	White
	066-080	Red/Green
	081-095	Red/Blue
	096-110	Red/White
	111-125	Green/Blue
	126-140	Green/White
	141-155	Blue/White
	156-170	Red/Green/Blue
	171-185	Red/Green/White
	186-200	Green/Blue/White
	201-215	Red/Green/Blue/White
	216-230	Automatic (4-color chase)
231-255	Automatic (7-color chase)	

DMX operation instructions

9 channel mode

4	000-005	No strobe
	006-255	Strobe (slow to fast)
5	000	function
	001-127	Motor indexing
	128-255	Motor speed
6	000-009	Black out
	010-019	Pattern 1(slow - fast)
	020-029	Pattern 2(slow-fast)
	030-039	Pattern 3(slow-fast)
	040-049	Pattern 4(slow-fast)
	050-059	Pattern 5(slow-fast)
	060-069	Pattern 6(slow-fast)
	070-079	Pattern 7(slow-fast)
	080-089	Pattern 8(slow-fast)
	090-099	Pattern 9(slow-fast)
	100-109	Pattern 10(slow-fast)
	110-119	Pattern 11(slow-fast)
	120-129	Pattern 12(slow-fast)
	130-139	Pattern 13(slow-fast)
	140-149	Pattern 14(slow-fast)
	150-159	Pattern 15(slow-fast)
	160-169	Pattern 16(slow-fast)
	170-179	Pattern 17(slow-fast)
180-255	Pattern 18 (slow-fast)	
7	000-009	Blackout
	010-049	Red
	050-089	Green
	090-129	Red & Green

DMX operation instructions

9 channel mode

7	130-169	Red on & Green strobe
	170-209	Green on & Red strobe
	210-255	Red & Green(alternate strobe)
8	000-009	No function
	010-254	strobe(slow-fast)
	255-255	Sound strobe
9	000-004	Stop
	005-127	Rotate Clockwise, slow to fast
	128-133	stop
	134-255	Rotate Anticlockwise, slow to fast

Remote Control Operation Instruction

Razor STL

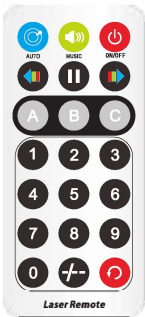

BUTTON	BUTTON	BUTTON
	ON/OFF	Power ON/OFF. When power on, press ON/OFF, light ON, press again light OFF, circle as it.
	AUTO	Press AUTO, enter into Auto mode, it will play Auto show randomly.
	MUSIC	Press MUSIC enter into Sound mode, it will play Auto show randomly.
	LED AUTO mode	Auto LED show. (Press A to open, press again to close)
	Strobe AUTO mode	Auto strobe show (Switching to different strobe modes,)
	Strobe ON/OFF	Strobe lighting on/off. (Press to open, press again to close.)
	Pause	Program and color change will be paused, press again to continue play.
	Color setting	Press these two buttons to change color.
	Numeric keys	Program speed setting. 0 is the slowest, 9 is the fastest

UK DISTRIBUTOR
John Hornby Skewes & Co. Ltd.
Salem House, Parkinson Approach, Garforth,
Leeds LS25 2HR, United Kingdom.
www.jhs.co.uk

Authorized EU Representative: Pieters Medical Agencies
Sporenlaan 19, 5407 2P Veghel, Netherlands