

# NIBCO® Press System Lead-Free Brass Ball Valves

**Features:** Press End Leak Detection • FIP Union • Two-Piece Body • PTFE Seats • Full Port • Blowout-Proof Stem

**Approvals:** MSS SP-110/145 • IAPMO/ANSI Z1157 • NSF/ANSI 61/372 • Conforms to ASME B16.51†

**Size range:** 1/2" - 1"

**Pressure rating:** 250 PSI non-shock cold working pressure

**Maximum pressure / temperature:** 225 PSI at 250° F

Lead-free markings: White handle and blue hang tag

**Applications:** Drinking Water • Domestic Hot & Cold Water • HVAC (condensors, chilled water, hot water heating) • Isolation and Throttling (half-open to full-open only) • Connect to Rigid Copper Tubing Manufactured per ASTM B88, Condition H (hard drawn)

Reference Press System catalog for updated Approved Tool and Jaw Compatibility Matrix list.

**Not intended for steam or gas usage.**



**PCFU-FP-600A-LF**

Press x FIP Union  
1/2" - 1"

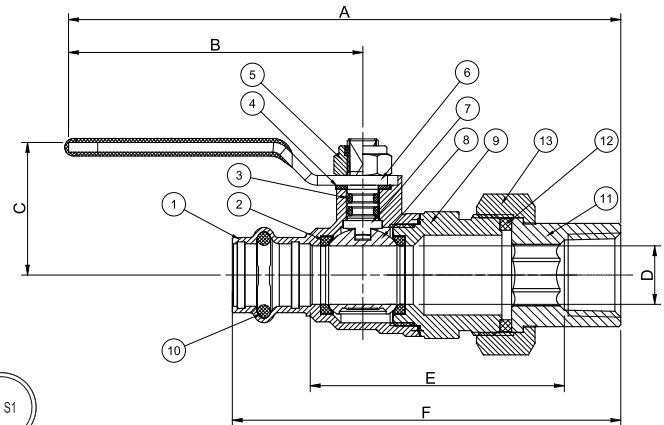

**PCFU-FP-600A-LF**

Press x FIP Union  
1/2" - 1"

## MATERIAL LIST

PART	SPECIFICATION
1. Body	Forged DZR Copper Alloy - C46500
2. Seat Seal	PTFE
3. O-ring	EPDM - ASTM D2000
4. Washer	PTFE
5. Lock Nut	Stainless Steel + Nylon
6. Handle	Steel, Plated
7. Stem	Brass
8. Ball	Chrome Plated Brass - C46500
9. End Cap	Forged DZR Copper Alloy - C46500
10. O-ring	EPDM - ASTM D2000
11. Fitting	Forged DZR Copper Alloy - C46500
12. Washer	EPDM
13. Nut	Brass

### Options:

- Extended lever
- EPDM Seal for Press Ends
- Wing Handle



Handle Markings

## DIMENSIONS—WEIGHTS—QUANTITIES

SIZE		A		B		C		D		E		F		Weight	
In.	mm.	In.	mm.	In.	mm.	In.	mm.	In.	mm.	In.	mm.	In.	mm.	Lbs.	Kg.
1/2"	12.70	6.23	158.20	3.62	92.00	1.34	34.00	0.59	15.00	2.57	65.20	3.93	99.70	0.7720	0.3501
3/4"	19.05	6.92	175.70	4.13	105.00	2.06	52.20	0.79	20.00	2.84	72.20	4.38	111.20	1.2040	0.5461
1"	25.40	7.17	182.20	4.13	105.00	2.21	56.20	0.98	25.00	3.11	79.00	4.77	121.20	1.7750	0.8051

**IAPMO/ANSI Z1157:** in addition to meeting ICG-157 test requirements, the IAPMO/ANSI Z1157 also requires Press ends to be fully tested to IAPMO PS-117 performance requirements which includes the following additional tests:

- |  |  |
|--|--|
| 1. Unrestrained Hydrostatic Pressure Test at 20 °C (68°F)  | 6. Hydraulic Shock (Water Hammer) Test         |
| 2. Unrestrained Hydrostatic Pressure Test at 93 °C (200°F) | 7. Vibration Test                              |
| 3. Static Torsion Test for Press Connections               | 8. Thermal Cycling Test                        |
| 4. Bending Test  | 9. Alternate Thermal Cycling Test              |
| 5. Vacuum Test   | 10. Dynamic Torsion Test for Press Connections |

†Tested to the performance criteria of ASME B16.51



**WARNING:** This product can expose you to chemicals including lead, which is known to the State of California to cause cancer and birth defects or other reproductive harm. For more information go to [www.P65Warnings.ca.gov](http://www.P65Warnings.ca.gov).

LEAD-FREE: Weighted average lead content ≤ 0.25%