

megamaster

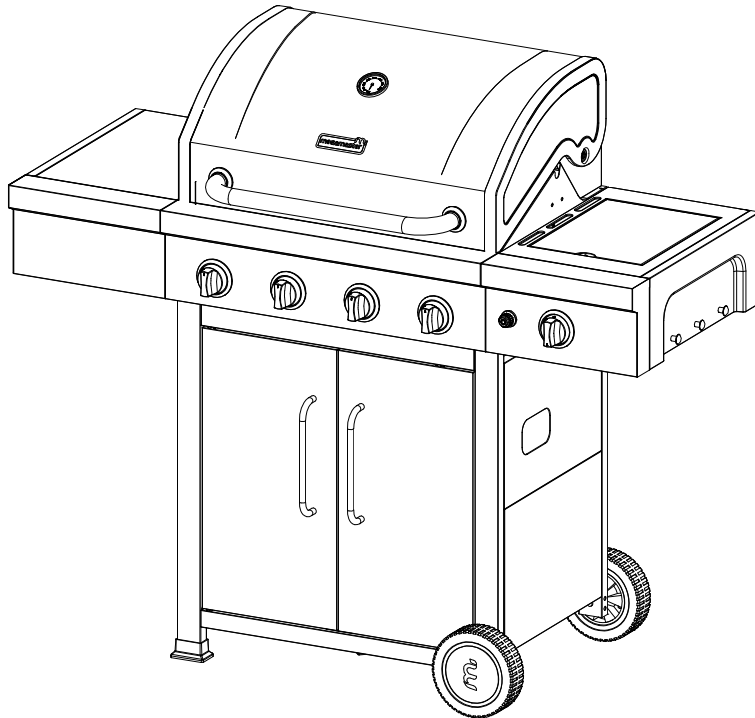

ASSEMBLY & OPERATING INSTRUCTIONS

Important: Read these instructions for use carefully so as to familiarize yourself with the appliance before connecting it to its gas container. Keep these instructions for future reference

LPGSASA Permit Number (1185/18/RSA-08/A)

www.megamaster.co.za

Manufactured in China· Distributed by Mega Group · PO Box 15, Woodlands, 0027, South Africa· Tel: +27(0)12 802 1515



WARNING

To reduce the risk of fire, burn hazard or other injury, read the manual carefully and completely before using your grill.



WARNING

This grill is not intended to be installed in or on recreational vehicles and/or boats.



WARNING

FOR OUTDOOR USE ONLY.

Table of Contents

Safety Instruction	2-7	Lighting Instruction.	29
Package Contents List	8-9	Care and Maintenance	30
Hardware Contents	10	Trouble Shooting	31-32
Exploded View	11	Grill Cooking Chart	33
Part List	12-13	Limited Warranty	34
Assembly Instruction	14-24		
Gas Hook –Up	25		
Installer Final Check List.	26		
Leak Testing	26-27		
Operating Instruction	28		
Grill Lighting Instruction	28-29		

Safety Instruction



DANGER

If you smell gas:

- 1. Shut off gas to the appliance.**
- 2. Extinguish any open flame.**
- 3. Open lid.**
- 4. If odor continues, keep away from the appliance and immediately call your gas supplier or your fire department.**



WARNING

- 1. Do not store or use gasoline or other flammable liquids or vapors in the vicinity of this or any other appliance.**
- 2. An LP gas cylinder not connected for use shall not be stored in the vicinity of this or any other appliance.**

Safety Instruction



DANGER

- 1. Never operate this appliance unattended.**
- 2. Never operate this appliance within 10 ft (3 m) of any structure, combustible material or other gas cylinder.**
- 3. Never operate this appliance within 25 ft (7.5 m) of any flammable liquid.**
- 4. Do not fill cooking vessel beyond maximum fill line.**
- 5. Heated liquids remain at scalding temperatures long after the cooking process. Never touch cooking appliance until liquids have cooled to 115°F (45°C) or less.**
- 6. This appliance is not intended for and should never be used as a heater.**
- 7. If a fire should occur, keep away from the appliance and immediately call your fire department. Do not attempt to extinguish an oil or grease fire with water.**

Safety Instruction

WARNING

Do not try lighting this appliance without reading the "LIGHTING INSTRUCTIONS" section of this manual.

It must be used with a 2, 8 kPa regulator that complies with Maximum LP gas cylinder size is 30cm in diameter by 52cm tall. .

Grill Installation Codes

Check your local building codes for the proper method of installation. In the absence of local codes, this unit should be installed in accordance with the South African National Standard 1539, Storage and Handling of Liquefied Petroleum Gases, Correct LP Gas Cylinder Use
LP gas grill models are designed for use with a standard 9kg LP Gas cylinder, not included with grill.
Never connect your gas grill to an LP gas cylinder that exceeds this capacity.

If an external electrical source is utilized for lights or rotisserie motors: The outdoor cooking gas appliance, when installed, must be electrically grounded in accordance with local codes or, in the absence of local codes.

WARNING

Keep any electrical supply cord and the fuel supply hose away from any heated surfaces

NOTE: The normal flow of gas through the regulator and hose assembly can create a humming noise. A low volume of noise is perfectly normal and will not interfere with operation of the grill. If humming noise is loud and excessive you may need to purge air from the gas line or reset the regulator excess gas flow device. This purging procedure should be done every time a new LP gas cylinder is connected to your grill.

CAUTION: Beware of Flashback

CAUTION: Spiders and small insects occasionally spin webs or make nest in the grill burner tubes during transit and warehousing. These webs can lead to gas flow obstruction, which could result in a fire in and around burner tubes. This type of fire is known as "BURN-BACK" and can cause serious damage to your grill and create an unsafe operating condition for the user.

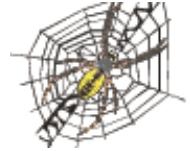

Although an obstructed burner tube is not the only cause of "BURN-BACK", it is the most common cause.

In the event of "BURN-BACK", where the flame burns back to the jet, immediately turn off the gas supply at the burner control valve.

After ensuring that the flame is extinguished, re-light the appliance as described in below. Should the appliance again "BURN-BACK", close the valves and examine the mixing tube or burner for any obstruction. If there are no obstructions and the burn back still occurs, call a technician to examine the appliance and make any necessary repairs.

Do not make any unnecessary adjustments or modifications to this grill, a qualified LP gas technician should do any adjustments.

To reduce the chance of "BURN-BACK", you must clean the burner tubes before assembling your grill, and at least once a month in late summer or early fall when spiders are most active. Also perform this burner tube cleaning procedure if your grill has not been used for an extended period of time. A clogged tube can be lead to a fire beneath the grill.

Visually check the burner flames prior to each use. The flames should look like this picture. If they do not, refer to the burner main tenancy part of this manual.

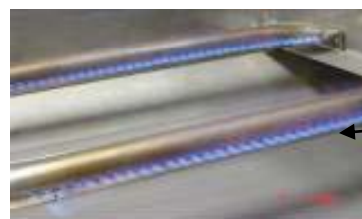

Safety Instruction

LP-Gas Supply System



- If the information is not followed exactly, a fire resulting in death or serious injury could occur.
- A 9kg cylinder of approximately 30cm in diameter by 52cm high is the maximum size LP gas cylinder to use.
- The safety feature prevents the cylinder from being overfilled, which can cause malfunction of the LP gas cylinder, regulator and/or grill.
- The LP gas supply cylinder to be used must be constructed and marked in accordance with the specifications for LP Gas cylinders in RSA .
- The LP gas cylinder must have a shutoff valve terminating in an LP valve outlet that is compatible with a Type 1. LP gas supply cylinder must have a shut off valve terminating in a valve outlet specified for connection type QCC1 in the standard for compressed gas cylinder valve outlet and inlet connection. LP gas supply cylinder must be fitted with an Overfill Protection Device (O.P.D) The LP gas cylinder must also have a safety relief device that has a direct connection with the vapor space of the cylinder.
- The cylinder supply system must be arranged for vapor withdrawal.
- The LP gas cylinder used must have a collar to protect the cylinder valve.
- Place dust cap on cylinder valve outlet whenever the cylinder is not in use. Only install the type of dust cap on the cylinder valve outlet that is provided with the cylinder valve. Other types of cap or plugs may result in leakage of gas.
- **Never** connect an unregulated LP gas cylinder to your gas grill.
- This outdoor cooking gas appliance is equipped with a high capacity hose/regulator assembly for connection to a standard 9kg. LP gas cylinder.
- Have your LP gas cylinder filled by a reputable LP gas dealer and visually inspected and re-qualified at each filling.
- Do not store a spare LP gas cylinder under or near this appliance.
- Never fill the cylinder beyond 80 percent full.
- Always keep LP gas cylinders in an upright position.
- Do not store or use gasoline or other flammable vapors and liquids in the vicinity of this or any other appliance.
- Storage of an outdoor cooking gas appliance indoors is permissible only if the cylinder is disconnected and removed from the outdoor cooking gas appliance.
- When your gas grill is not in use the gas must be turned off at LP gas cylinder.
- The gas must be turned off at the supply cylinder when the outdoor cooking gas appliance is not in use.
- LP gas cylinder must be stored outdoors in a well-ventilated area and out of reach of children. Disconnected LP gas cylinders must not be stored in a building, garage or any other enclosed area.
- Do Not obstruct the flow of ventilation air around the gas grill housing. Only use the regulator and the hose assembly supplied with your gas grill. Replacement regulators and hose assemblies must be those specified in this manual.
- The regulator and hose assembly must be inspected before each use of the grill. If there is excessive abrasion or wear or if the hose is cut, it must be replaced prior to the grill being put into operation. The replacement hose assembly shall be that specified by the manufacturer.
- Pressure regulator and hose assembly supplied with the outdoor cooking gas appliance must be used. Never substitute other types of regulator. Contact customer service for manufacturer specified replacement parts.
- This outdoor cooking gas appliance is equipped with a pressure regulator comply with the standard for LP gas products in South Africa.
- Do not use briquettes of any kind in the grill.
- The grill is designed for optimum performance without the use of briquettes. Do not place briquettes on the radiant as this will block off the area for the grill burners to vent. Adding briquettes can damage ignition components and knobs, and void the warranty.
- Keep the back and side cart free and clear from debris. Keep any electrical supply cord, or the rotisserie motor cord away from the heated areas of the grill.
- Never use the grill in extremely windy conditions. If located in a consistently windy area (oceanfront, mountaintop, etc.) a windbreak will be required. Always adhere to the specified clearance.
- Never use a dented or rusty propane cylinder.
- Keep any electrical supply cord and the fuel supply hose away from any heated surface.
- While lighting, keep your face and hands as far away from the grill as possible.
- Burner adjustment should only be performed after the burner has cooled.

Safety Instruction

PROPER PLACEMENT AND CLEARANCE OF GRILL

- Never use your gas grill in a garage, porch, shed, breezeway or any other enclosed area. Your gas grill is to be used outdoors only. Do Not install this unit into combustible enclosures. Minimum clearance from sides and back of unit to combustible construction, 24 inches (61cm) from sides and 24 inches (61cm) from back.
- **DO NOT** use this appliance under overhead combustible surfaces. This outdoors cooking gas appliance is not intend to be installed in or on recreational vehicles and/or boats.



INSECT WARNING

Spiders and insects can nest in the burners of this and any other grill, and cause the gas to flow improperly. This is a very dangerous condition, which can cause a fire to occur behind and beneath the valve panel, thereby damaging the grill and making it unsafe to operate. Inspect the grill at least twice a year.



WARNING

Keep a spray bottle of soapy water near the gas supply valve and check the connections before each use.

DO NOT USE ALUMINUM FOIL TO LINE THE GRILL RACKS OR GRILL BOTTOM.

This can severely upset combustion airflow or trap excessive heat in the control area.

DO NOT LEAVE THE GRILL UNATTENDED WHILE COOKING.



WARNING

Your grill will get very hot. Never lean over the cooking area while using your grill. Do not touch cooking surfaces, grill housing, lid or any other grill parts while the grill is in operation, or until the gas grill has cooled down after use.

Failure to comply with these instructions may result in serious bodily injury.

CAUTION: TO ENSURE CONTINUED PROTECTION AGAINST RISK OF ELECTRIC SHOCK, CONNECT TO PROPERLY GROUNDED OUTLETS ONLY, TO REDUCE THE RISK OF ELECTRIC SHOCK, KEEP EXTENSION CORD CONNECTION DRY AND OFF THE GROUND.

SAFETY PRACTICES TO AVOID PERSONAL INJURY

When properly cared for your grill will provide safe, reliable service for many years. However, extreme care must be used as the grill produces intense heat that can increase accident potential. When using this appliance basic safety practices must be followed, including the following:

Do not repair or replace any part of the grill unless specifically recommended in this manual. All other service should be referred to a qualified technician. This grill is not intended to be installed in or on recreational vehicles or boats.

Children should not be left alone or unattended in an area where the grill is being used. Do not allow them to sit, stand or play in or around the grill at any time. Do not store items of interest to children around or below the grill.

Do not permit clothing, pot holders or other flammable materials to come in contact with or too close to any grate, burner or hot surface until it has cooled. The fabric could ignite and cause personal injury.

For personal safety, wear proper apparel. Loose fitting garments or sleeves should never be worn while using this appliance. Some synthetic fabrics are highly flammable and should not be worn while cooking.

Only certain types of glass, heat-proof glass ceramic, earthenware, or other glazed utensils are suitable for grill use. These materials may break with sudden temperature changes. Use only on low or medium heat settings in accordance with the manufacturer's guidelines.

Safety Instruction

Do not heat unopened food containers. A build-up of pressure may cause the containers to burst.

Use a covered hand when opening the grill lid.
Never lean over an open grill.

When lighting a burner, pay close attention to what you are doing. Make certain you are aware of which burner you are lighting, so your body and clothing remain clear of open flames.

When using the grill, do not touch the grill rack, burner grate or immediate surroundings as these areas become extremely hot and could cause burns. Use only dry potholders. Moist or damp potholders on hot surfaces may cause steam burns. Do not use a towel or bulky cloth in place of potholders. Do not allow potholders to touch hot portions of the grill rack.

Grease is flammable. Let hot grease cool before attempting to handle it. Do not allow grease deposits to collect in the grease tray at the bottom of the grill's firebox. Clean the grease tray often.

Do not use aluminum foil to line the grill racks or grill bottom. This can severely upset combustion air flow or trap excessive heat in the control area.

For proper lighting and performance of the burners keep the burner ports clean. It is necessary to clean them periodically for optimum performance. The burners will only operate in one position and must be mounted correctly for safe operation.

Clean the grill with caution. To avoid steam burns, do not use a wet sponge or cloth to clean the grill while it is hot. Some cleaners produce toxic fumes or can ignite if applied to a hot surface.

Turn off grill controls and make certain the grill is cool before using any type of aerosol cleaner on or around the grill. The chemical that produces the spraying action could, in the presence of heat, ignite or cause metal parts to corrode.

Do not use the grill to cook excessively fatty meats or other products which promote flare – ups.

Do not operate the grill under unprotected combustible constructions. Use only in well ventilated areas. Do not use in buildings, garages, sheds, breezeways or other such enclosed areas.









Keep the area surrounding the grill free from combustible materials including, fluids, trash, and vapors such as gasoline or charcoal lighter fluid. Do not obstruct the flow of combustion and ventilation air.

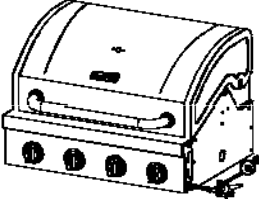
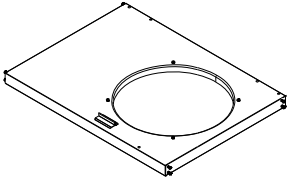
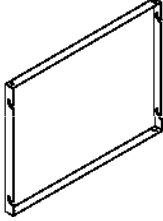
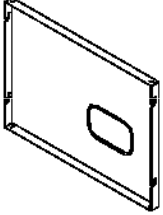
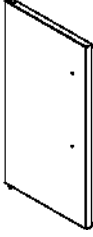
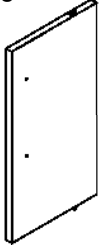
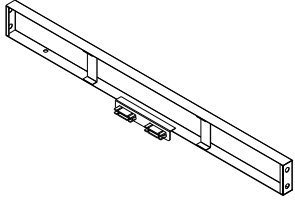



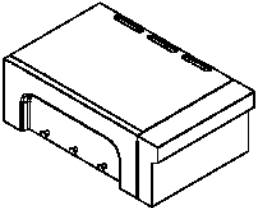
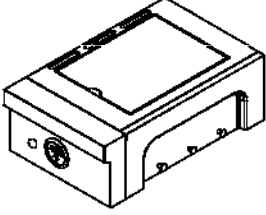
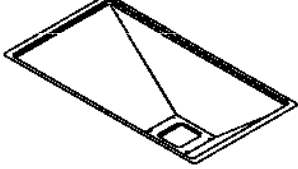

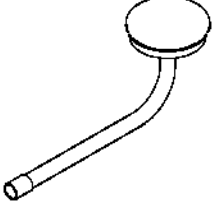
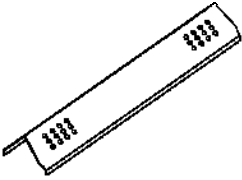
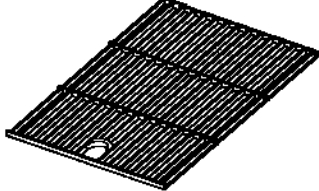
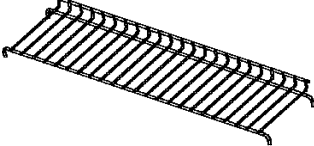
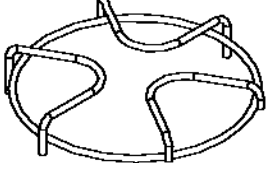
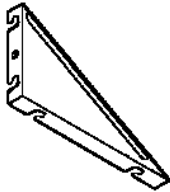
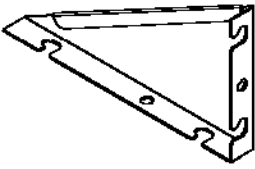
WARNING

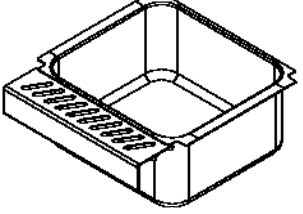

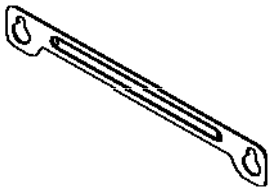
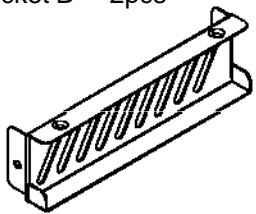
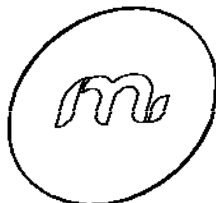
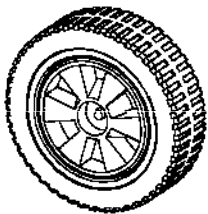
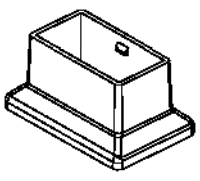
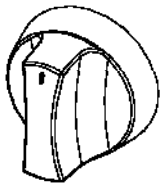
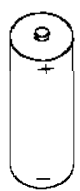
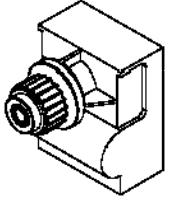

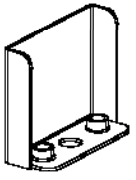
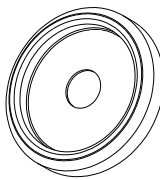

This outdoor cooking gas appliance is not intended to be installed in or on boats. And other recreational vehicles.

Package Contents List

<p>A. Firebox Assembly----1pc</p> 	<p>B. Bottom panel----1pc</p> 	<p>C. Side panel----3pcs</p> 	<p>D. Side panel right, top ----1pc</p> 
<p>E. Door, left----1pc</p> 	<p>F. Door, right----1pc</p> 	<p>G. Cart frame----1pc</p> 	<p>H. Cart leg front, left----1pc</p> 
<p>I. Cart leg rear, left----1pc</p> 	<p>J. Cart leg front, right----1pc</p> 	<p>K. Cart leg rear, right----1pc</p> 	<p>L. Side shelf, left----1pc</p> 
<p>M. Side Burner, right----1pc</p> 	<p>N. Grease tray----1pc</p> 	<p>O. Door handle----2pcs</p> 	<p>P. Side tube burner----1pc</p> 
<p>Q. Flame tamer----3pcs</p> 	<p>R. Cooking grid---2pcs</p> 	<p>S. Warming rack----1pc</p> 	<p>T. Side burner cooking grid ----1pc</p> 
<p>U. Triangle bracket, left ----1pc</p> 	<p>V. Triangle bracket, right ----1pc</p> 	<p>W. Cylinder support bracket ---2pcs</p> 	<p>X. Grease box----1pc</p> 

<p>Y. Grease cup support bracket A----1pc</p> 	<p>Z. Grease cup support bracket B----2pcs</p> 	<p>AA. Wheel cap----2pcs</p> 	<p>AB. Wheel----2pcs</p> 
<p>AC. Cart caster insert ----2pcs</p> 	<p>AD. Control knob----1pc</p> 	<p>AE. 1.5 Volt "AA" Size Alkaline Battery----1pc</p> 	<p>AF. Pulse igniter module ----1pc</p> 
<p>AG. Temperature gauge ----1pc</p> 	<p>AH. Grease tray latch ----1pc</p> 	<p>AI. Temperature gauge seat ----1pc</p> 	<p>AJ. Side burner igniter wire ----1pc</p> 

Hardware Contents

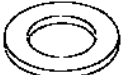
REF#	Description	Specification	QTY
H1	Truss Head Screw 	5/32" x 10mm	14pcs.
H2	Truss Head Screw 	1/4" x 12mm	18pcs.
H3	Nut 	1/4"	2pcs.
H4	Flat Washer (Aluminum) 	M4	4pcs.
H5	Flat Washer 	M5	2pcs.
H6	Flat Washer (Aluminum) 	M6	6pcs.
H7	Flat Washer (Black) 	M6	2pcs.

Before beginning assembly, make sure all parts are present. Compare parts with package contents list and diagram. If any part is missing or damaged, do not attempt to assemble the product. Contact customer service for replacement parts.

•Estimated Assembly Time:40 minutes

•Tools required for assembly:

Truss Screwdriver (not included)

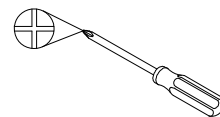

Truss Screwdriver

•Note: The left and right sides of the grill are designated as if you are facing the front of the grill.

Explode View

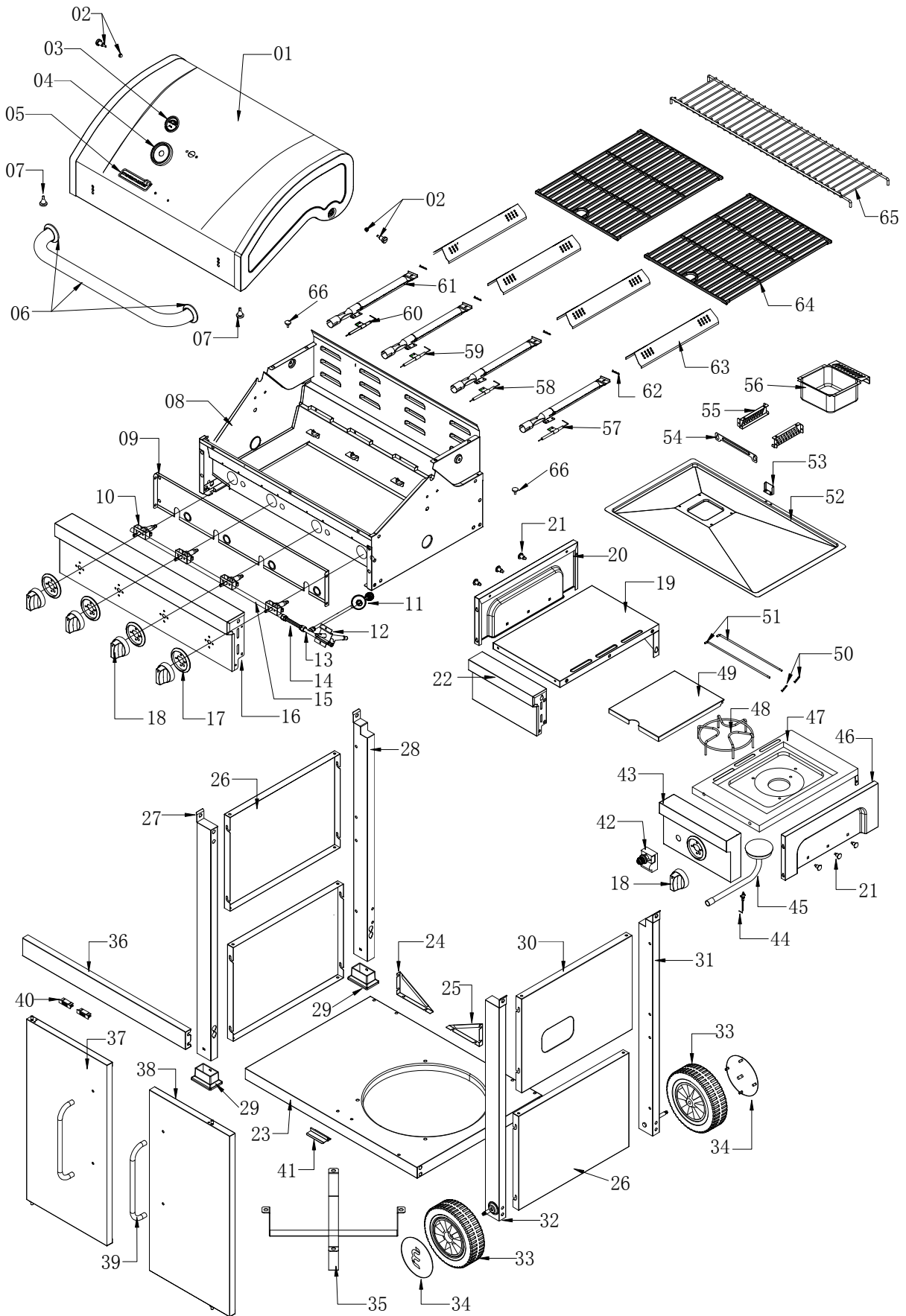

No	Part (Description)	Warranty coverage (year)	QTY	No	Part (Description)	Warranty coverage (year)	QTY
1	Main lid	1	1	32	Cart leg front, right	1	1
2	Main lid screw	1	2	33	Wheel	1	2
3	Temperature gauge	1	1	34	Wheel cap	1	2
4	Temperature gauge seat	1	1	35	Cylinder support bracket	1	2
5	Logo	1	1	36	Cart frame	1	1
6	Main lid handle	1	1	37	Door, left	1	1
7	Hood buffer A	1	2	38	Door, right	1	1
8	Main burner bowl assembly	Non-replaceable	1	39	Door handle	1	2
9	Front baffle	1	1	40	Door magnet	1	2
10	Main gas valve	1	4	41	Door iron piece	1	1
11	Regulator, LP	1	1	42	Pulse igniter module	1	1
12	Side burner gas valve	1	1	43	Side burner control panel, right	1	1
13	Side manifold	1	1	44	Side burner igniter wire	1	1
14	Side burner flex gas line	1	1	45	Side tube burner	1	1
15	Main manifold	1	1	46	Side burner end cap, right	1	1
16	Main control panel	1	1	47	Side burner bowl assembly	1	1
17	Bezel	1	4	48	Side burner cooking grid	1	1
18	Control knob	1	5	49	Side burner lid	1	1
19	Side shelf, left	1	1	50	Side burner lid hinge rod pin	1	2
20	Side shelf end cap, left	1	1	51	Side burner lid hinge rod	1	2
21	Hooks	1	6	52	Grease tray	1	1
22	Side shelf front panel, left	1	1	53	Grease tray latch	1	1
23	Bottom panel	1	1	54	Grease cup support bracket A	1	1
24	Triangle bracket, left	1	1	55	Grease cup support bracket B	1	2
25	Triangle bracket, right	1	1	56	Grease box	1	1
26	Side panel	1	3	57	Main burner igniter wire A	1	1
27	Cart leg front, left	1	1	58	Main burner igniter wire B	1	1
28	Cart leg rear, left	1	1	59	Main burner igniter wire C	1	1
29	Cart caster insert	1	2	60	Main burner igniter wire D	1	1
30	Side panel right, top	1	1	61	Main burner	3	4
31	Cart leg rear, right	1	1	62	Main burner pin assembly	1	4

No .	Part (Description)	Warranty coverage (year)	QTY	No .	Part (Description)	Warranty coverage (year)	QTY
63	Flame tamer	1	4				
64	Cooking grid	1	2				
65	Warming rack	1	1				
66	Hood buffer B	1	2				

Assembly Instructions

1. Cart Assembly

- a) Place the Cart Caster Inset (AC) into the Cart Leg Front Left (H) and Cart Leg Rear Left (I). As shown in Fig. 1.

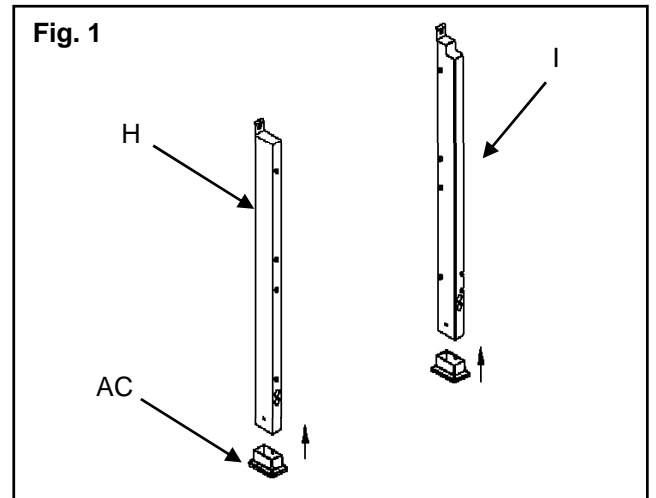

- b) Loosen but do not remove the eight screws that were pre-assembled on the Cart Leg Front Left (H) and Cart Leg Rear Left (I). Attach Cart Leg Front Left (H) and Cart Leg Rear Left (I) to Side Panel (C) by aligning the holes on the Side Panel (C). Tighten the screws that were loosened above. As shown in Fig. 2.

Note: Make sure the flat side of Side Panel (C) faces out to the left when attaching.

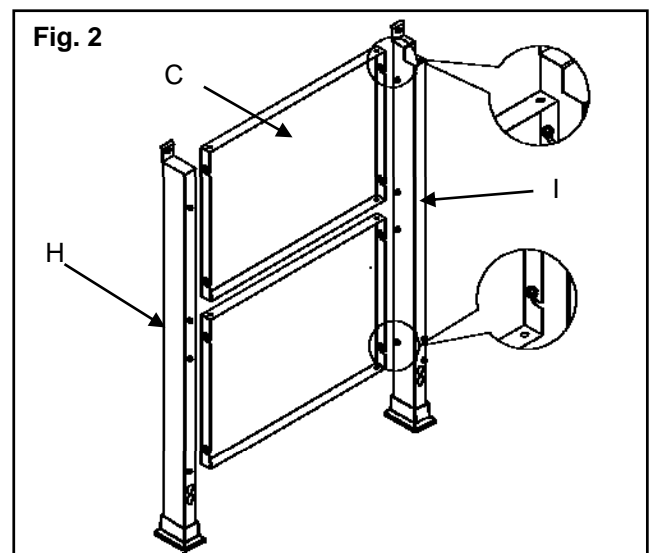

- c) Loosen but do not remove the eight screws that were pre-assembled on the Cart Leg Front Right (J) and Cart Leg Rear Right (K). Attach Cart Leg Front Right (J) and Cart Leg Rear Right (K) to Side Panel (C) and Side Panel Right Top (D) by aligning the holes on the Side Panel (C) and Side Panel Right Top (D). Tighten the screws that were loosened above. As shown in Fig. 3.

Note: Make sure the flat side of Side Panel (C) and Side Panel Right Top (D) face out to the right when attaching.

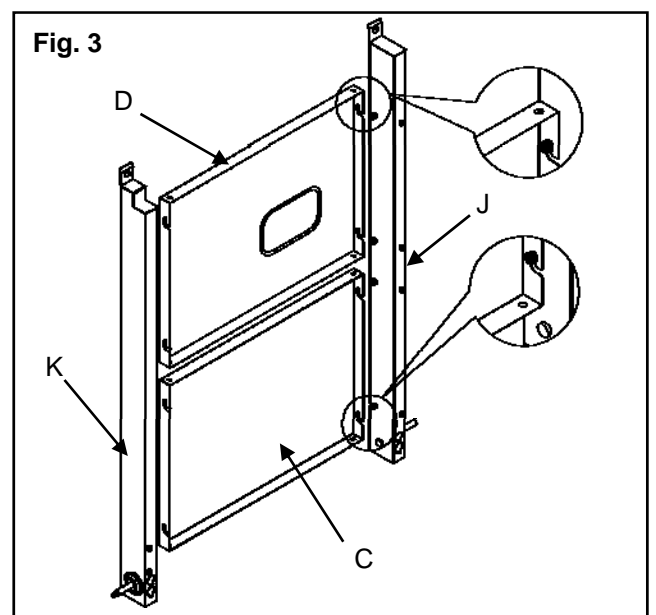

2. Bottom Panel Assembly

- a) Loosen but do not remove the screws that were pre-assembled on the side of the Bottom Panel (B), align the holes on the Cart Leg Front Left (H) and Cart Leg Rear Left (I), then place the cart legs onto the screws that were loosened in the Bottom Panel (B). As shown in Fig. 4.
- b) Tighten the screw from outside to inside, there is a hole in the outside of the cart leg. As shown in Fig.4.
- c) Repeat step 2a and 2b to attached the right legs to the Bottom Panel (B), make sure all screws are tight.

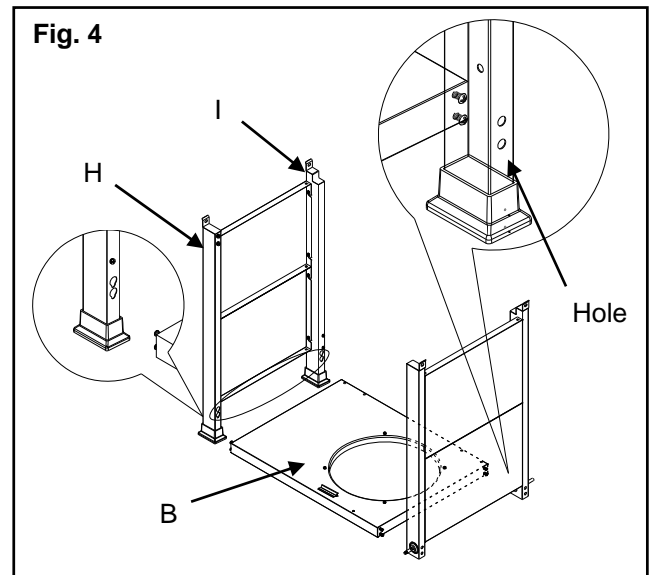

3. Cart Frame Assembly

Attached Cart Frame (G) to the Cart Leg Front Left (H) and Cart Leg Front Right (J) by using 4pcs Truss Head Screws (H2), As shown in Fig.5.

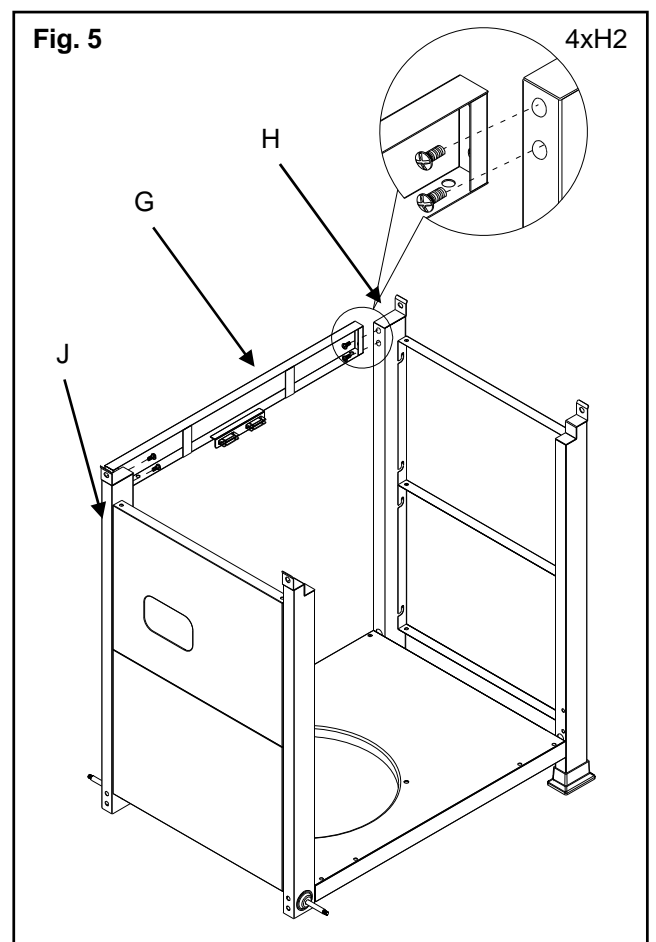

4. Triangle Bracket Assembly

- a) Loosen but do not remove four screws on Bottom Panel (B), two screws on Cart Leg Rear Left (I) and two screws on Cart Leg Rear Right (K). Align the holes of the Triangle brackets with the screws in the Bottom Panel (B) and Cart Leg Rear Left (I) and Cart Leg Rear Right (K) to connect Triangle Bracket Left (U) and Triangle Bracket Right (V) to Cart Leg Rear Left (I) and Cart Leg Rear Right (K). As shown in Fig. 6.
- b) Tighten the screws.

Note: The flat portion of the triangle brackets should face the rear of the grill.

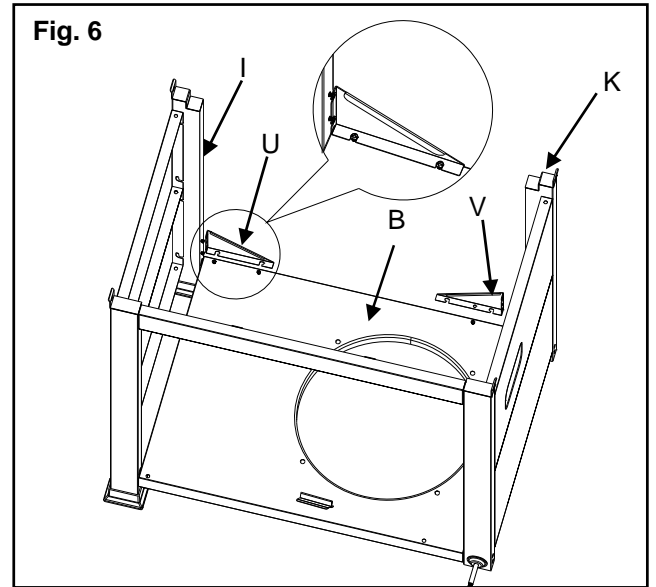

5. Wheel Assembly

- a) Place the wheel (AB) on the Axle attached to Cart Leg Front Right (J) and Cart Leg Rear Right (K), place 1pc Flat Washer (H7) to the wheel then place and tighten 1pc Nuts (H3) on the Axle. As show in Fig. 7.
- b) Repeat step 5a to attached the other wheel.
- c) Attached the Wheel Caps (AA) on both Wheels as shown in Fig.7

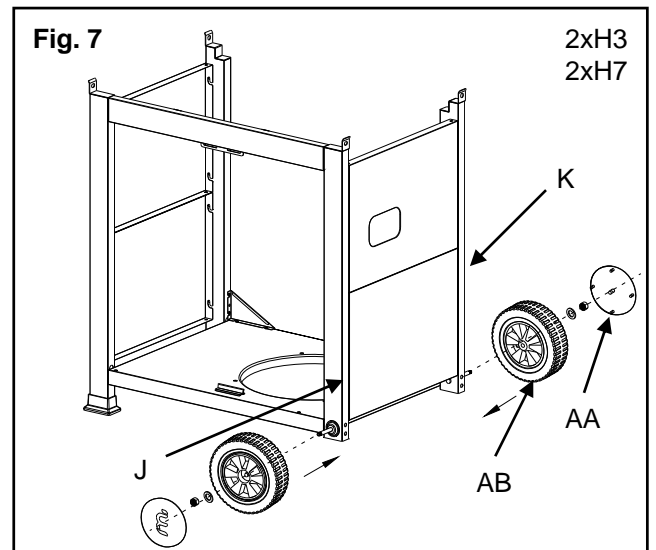

6. Cylinder Support Bracket Assembly

Mount the Cylinder Support Bracket (W) onto the Bottom Panel (B) using 4pcs Truss Head Screws (H2). As show in Fig. 8.

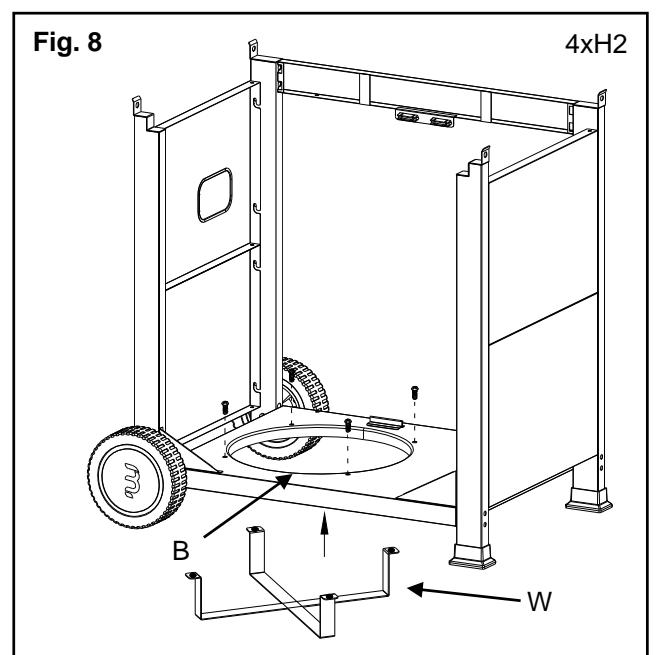

7. Door assembly

- a) Attach the Door Handle (O) to each door (E/F) by using 4pcs Truss Head Screws (H1). As show in Fig. 9.

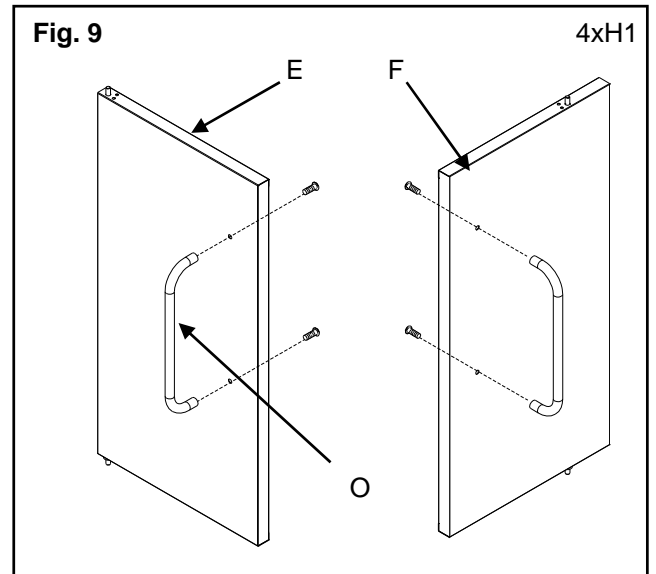

- b) Insert the bottom hinge pin of Door Left (E) into the hole in the bottom panel. Then push down the spring-loaded top hinge pin and allow it to spring back up into the hole under the Cart Frame (G). As show in Fig.10.

- c) Repeat this assembly procedure for the Door Right (F). As shown in Fig. 10.

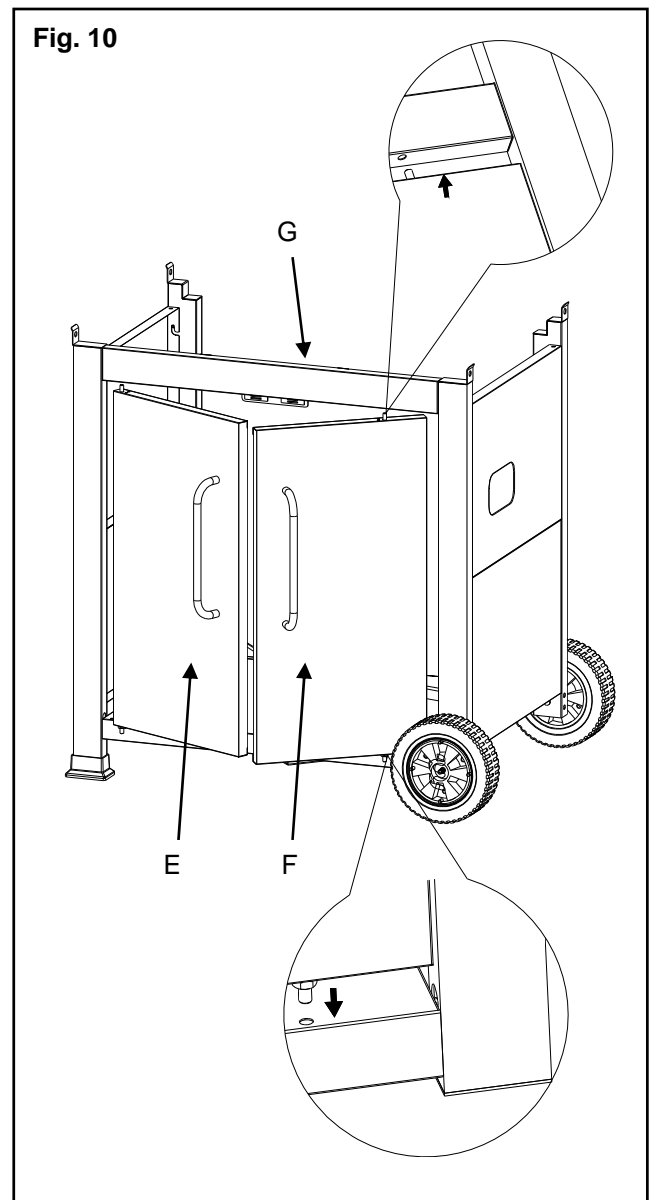

8. Firebox Assembly

NOTE: The firebox assembly is heavy and will require two or more people to lift and position onto grill cart. Failure to do so may result in injury. Be sure to remove all packaging material during assembly.

- a) Remove the Firebox Assembly (A) from the carton and carefully place onto the grill cart. Lid handle will face front and be above front panel. As shown in Fig.11.
- b) Attach Firebox (A) to the grill cart by using 4pcs Truss Head Screws (H2). As shown in Fig. 11.

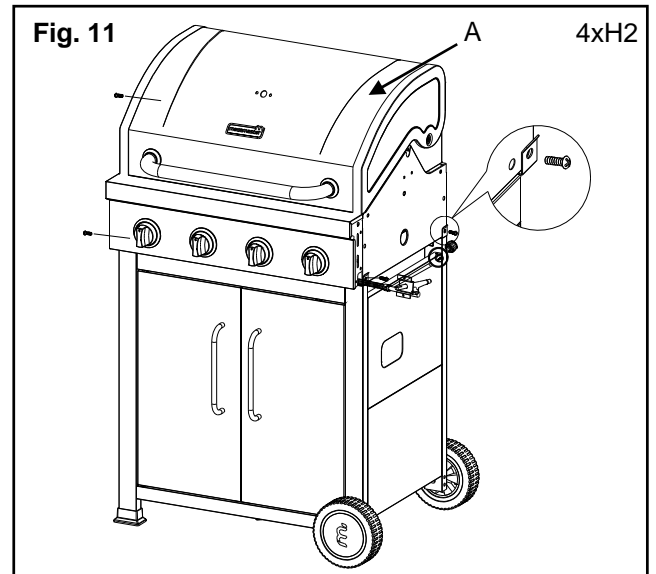

9. Temperature Gauge Assembly

Attach Temperature Gauge (AG) and Temperature Gauge Seat (AI) to the lid by using 1pc hex nut that pre-assembly on the temperature gauge. As shown in Fig. 12.

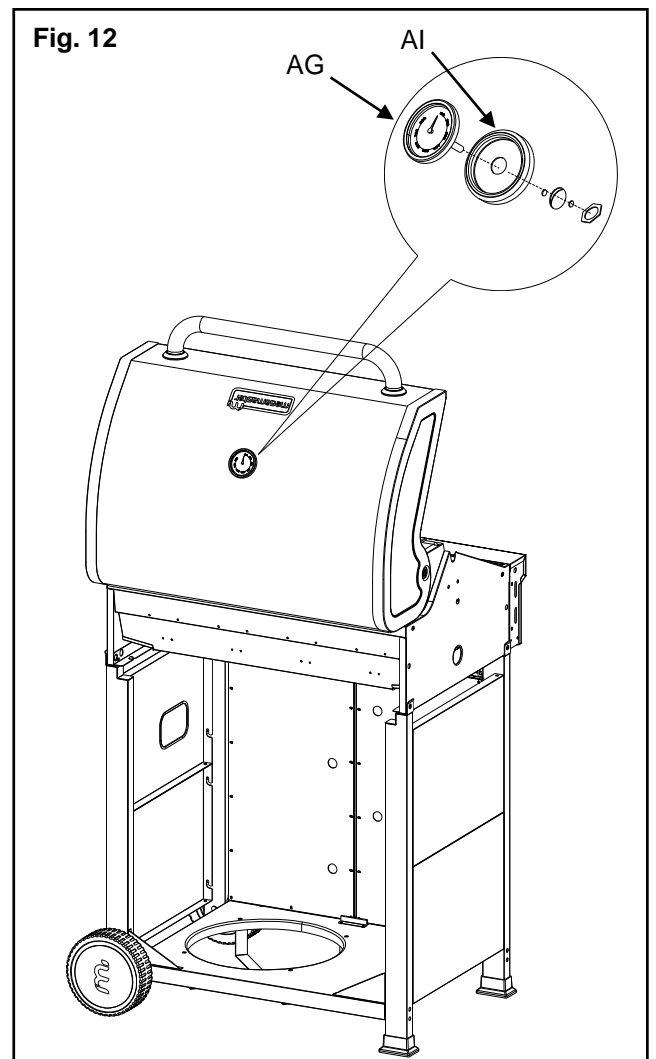

10. Side Shelf Left Assembly

a) Loosen but do not remove two screws which were pre-assembled on left side of Firebox (A). Align the holes and secure the Side Shelf Left (L) from inside firebox by using 3pcs Truss Head Screws (H2) and 3pcs Flat Washers (H6) to attach the Side Shelf Left (L) to the Firebox (A). As shown in Fig.13 and Fig.14.a1.

b) Tighten screws loosened in 10a. Ensure all screws are tight.

c) Using 1pc Truss Head Screw (H1) and 1pc Flat Washer (H5) to attached the Side Shelf Left (L) to the left side of main control panel. As shown in Fig.14.a2.

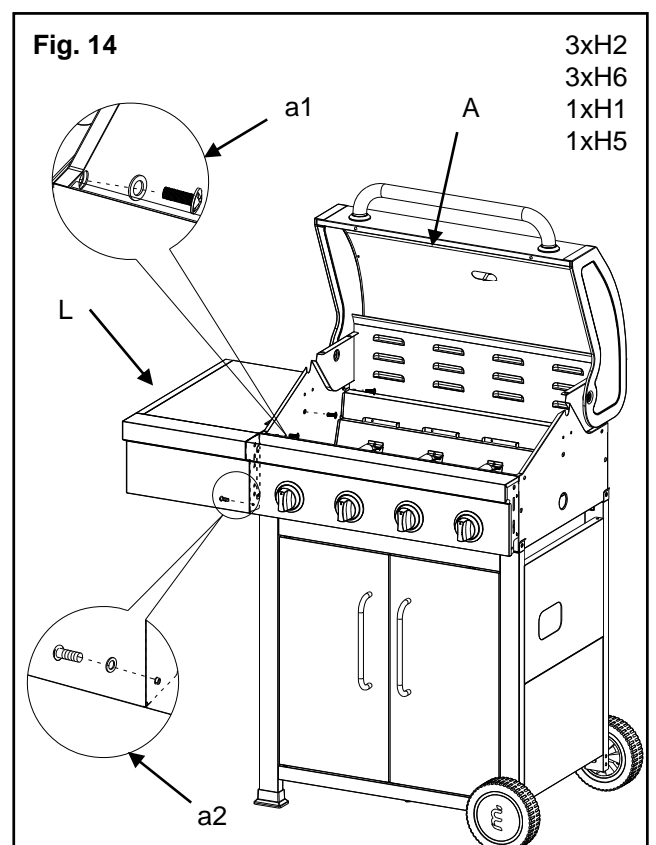
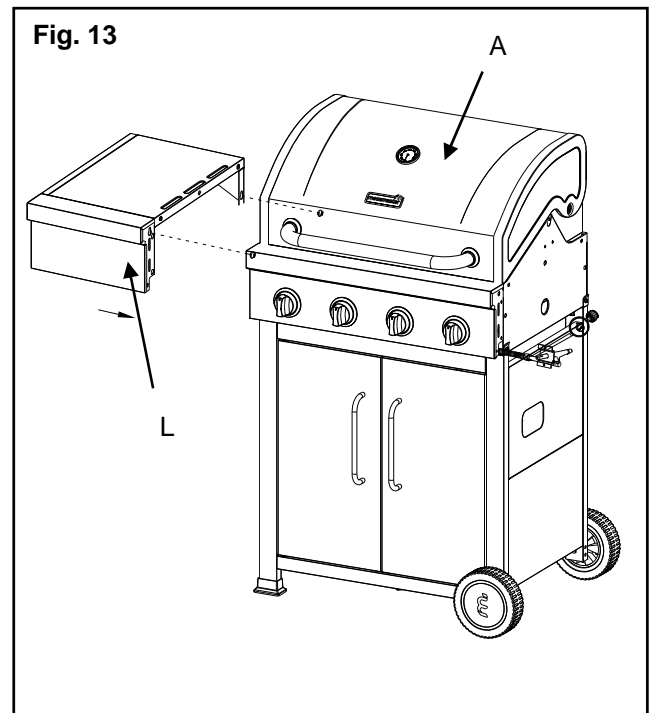

11. Side Burner Right Assembly

- a) Loosen but do not remove two screws which are pre-assembled on right side of Firebox (A). Align the holes and secure the Side Burner Right (M) from inside firebox by using 3pcs Truss Head Screws (H2) and 3pcs Flat Washers (H6) to attach the Side Burner Right (M) to the Firebox (A). As shown in Fig.15 and Fig.16.a1.
- b) Tighten screws loosened in 11a. Ensure all screws are tight.
- c) Using 1pc Truss Head Screw (H1) and 1pc Flat Washer (H5) to attached the Side Burner Right (M) to the right side of main control panel. As shown in Fig.16.a2.

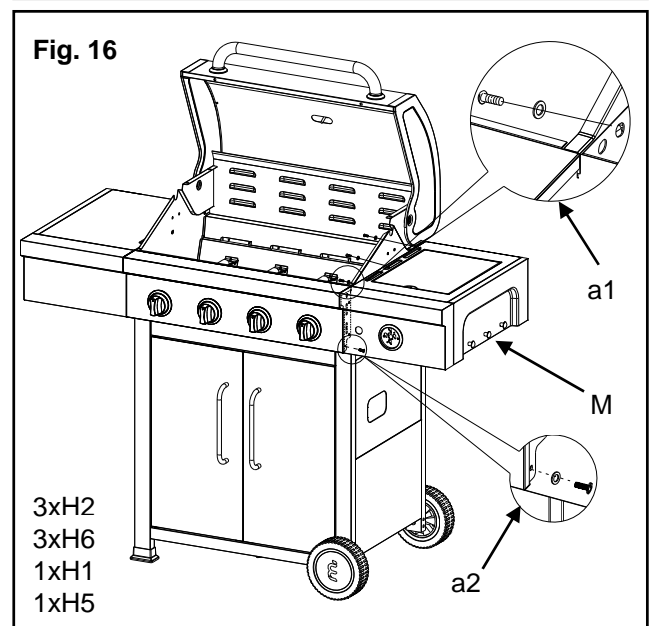
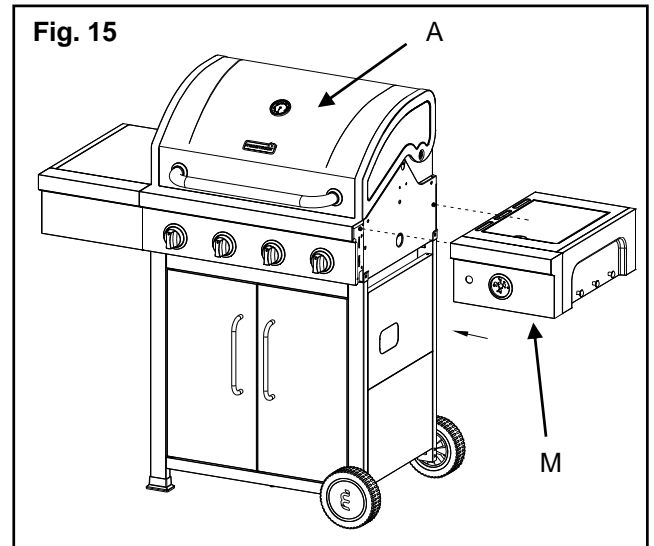

12. Pulse Igniter Module and Battery Assembly

- a) Remove igniter battery cap and lock washer from igniter. Insert Pulse Igniter Module (AF) through from back of side burner control panel, secure lock washer from front of side burner control panel. As shown in Fig.17.
- b) Install Battery (AE) into ignition box with positive terminal (+) facing outward.
- c) Replace the ignition battery cap after the Battery has been installed. As shown in Fig.17.

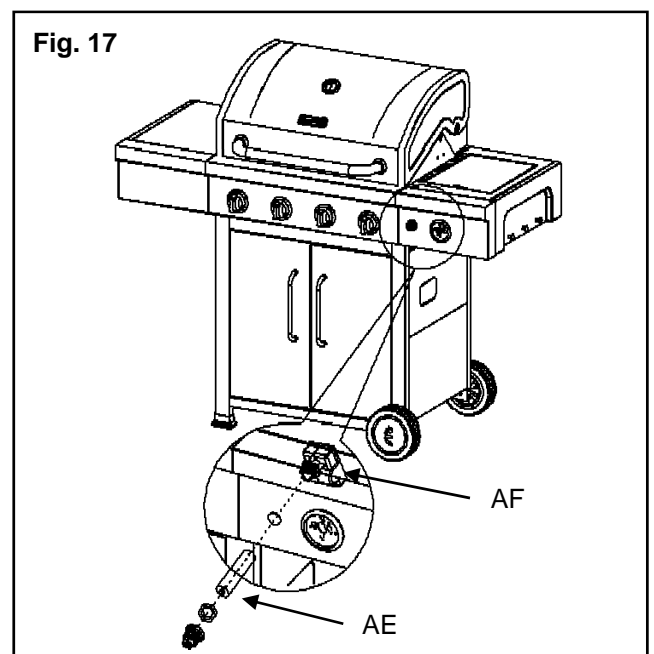

- d) Insert the ignition wires to the Pulse Ignition Module (AF) located on the right side burner control panel. As shown in Fig.18.

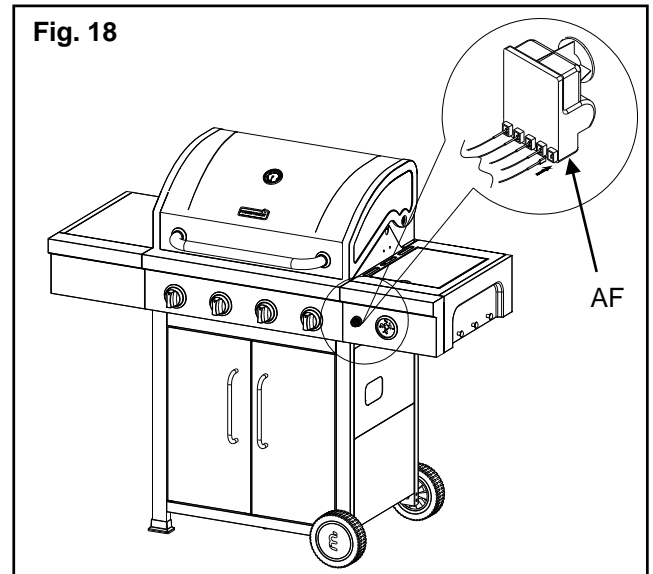

13. Side Burner Installation

- a) Loosen the screws which from underneath the side burner to remove two screws which are pre-assembled on the bottom of the Side Burner Right (M). Open side burner lid and place the Side Tube Burner (P) through the opening. Place the Side Tube Burner (P) tube over the side burner gas Valve and make sure side burner gas valve is inserted into side burner tube. Then with two screws secure the side burner from underneath to the Side Burner Right (M). As shown in Fig. 19. and Fig.20.a1.

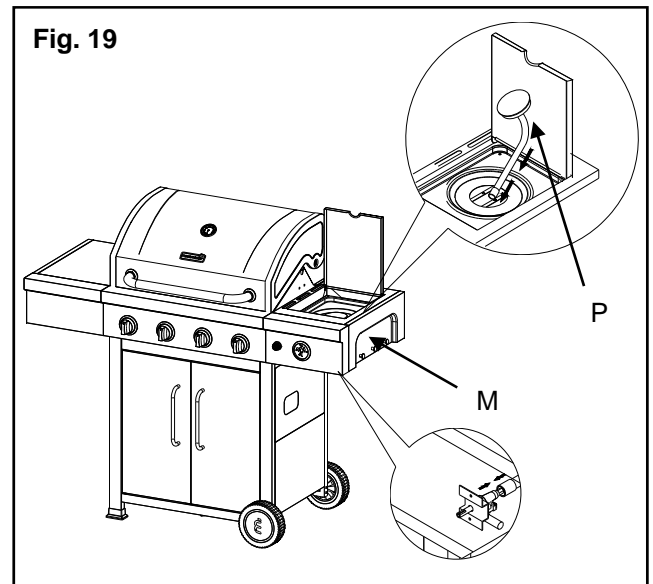

- b) Connect Side Burner Ignition Wire (AJ) to the side burner igniter pin from underneath the Side Burner Shelf & Control Panel. As shown in Fig.20.a2.

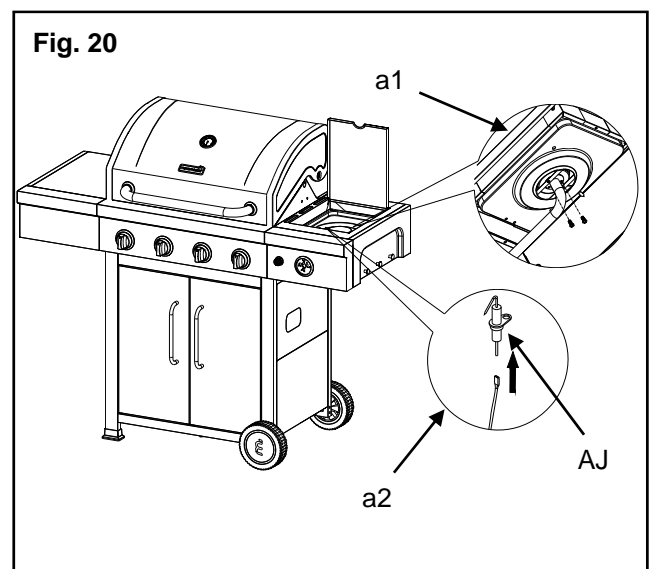

- c) Loosen the screws which pre-assembled on the side burner gas valve then align the screws to the valve with the large side of the holes on the bezel, fix with vertical gourd holes, then tighten the screws. As shown in Fig. 21.

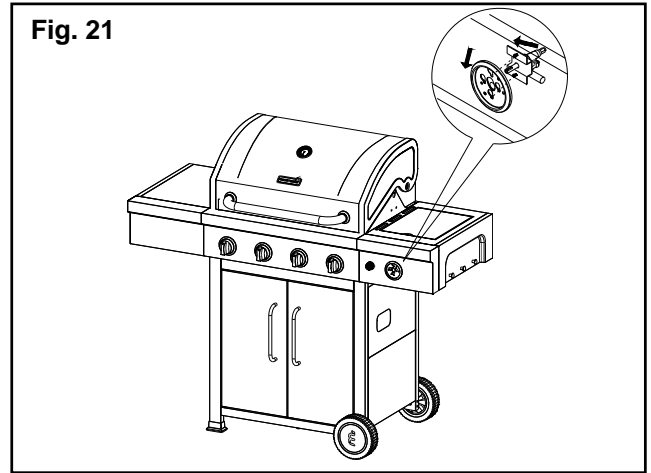

- d) Insert Side Burner Control Knob (AD) into the valve stem and tighten it. As shown in Fig.22.

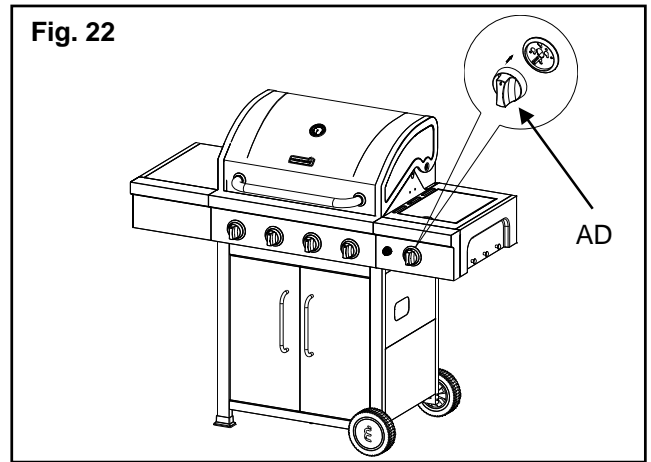

14. Grease Tray and Grease Box Installation

- a) Attached Grease Tray Latch (AH) to Grease Tray (N) by using 2pcs Truss Head Screw (H1). As shown in Fig.23.

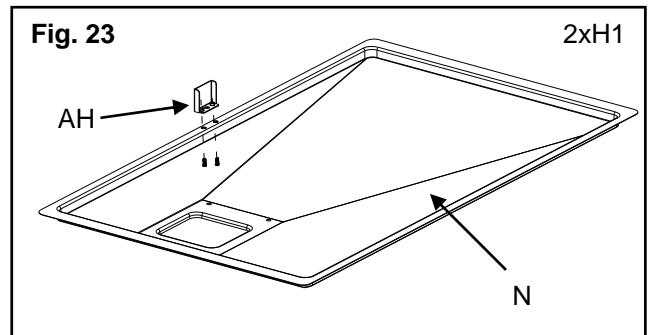

- b) Attached Grease Cup Support Bracket B (Z) to Grease Tray (N) by using 4pcs Truss Head Screw (H1) and 4pcs Flat Washers (H4). As shown in Fig.24.

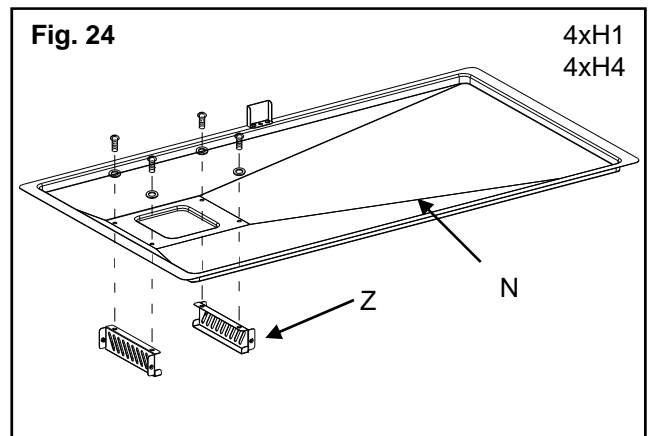

- c) Then attached Grease Cup Support Bracket A (Y) to Grease Box Support Bracket B (Z) by using 2pcs Truss Head Screws (H1). As shown in Fig.23.

Note: Make sure the Grease Cup Support Bracket A (Y) is attached in the right position, as show in Fig.25.

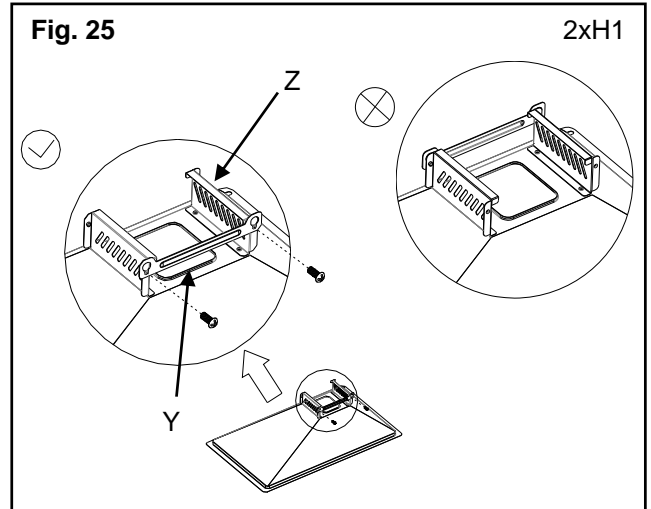

- d) Install the Grease Tray (N) from the rear of the grill by sliding the tray on the glides at the rear of the grill until centered under the cooking area. As shown in Fig.26.

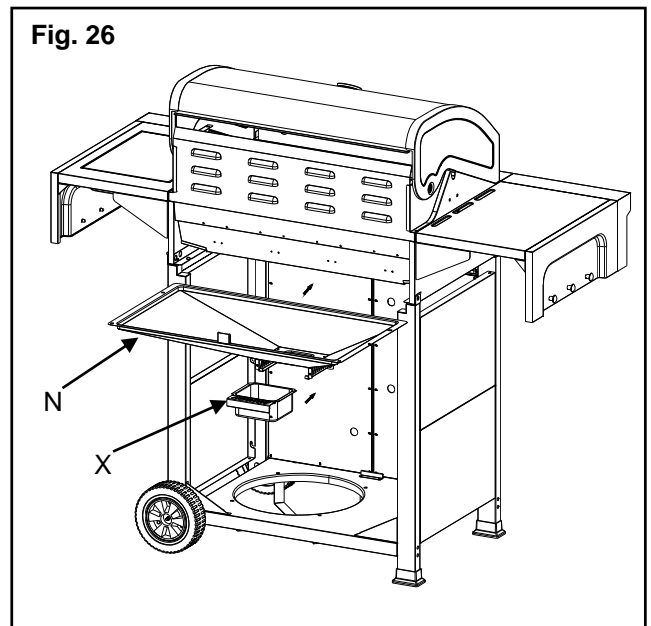

- e) Install the Grease Box (X) under the Grease Tray (N). As shown in Fig. 26.

15. Cooking Components Installation

- a) Place the Flame Tamers (Q), Cooking Grids (R) into the grill. As shown in Fig. 27.

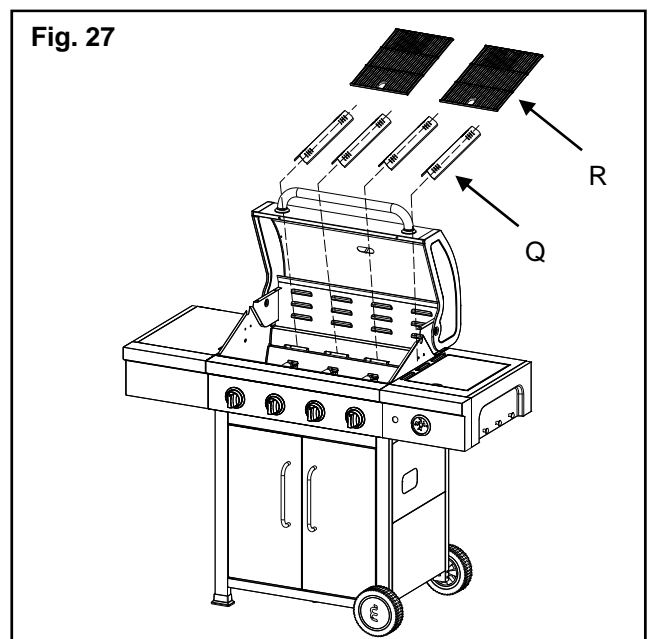

- b) Insert legs of Warming Rack (S) into the holes on the top of firebox side panels. Place Side Burner Cooking Grid (T) into the side burner. As shown in Fig.28.

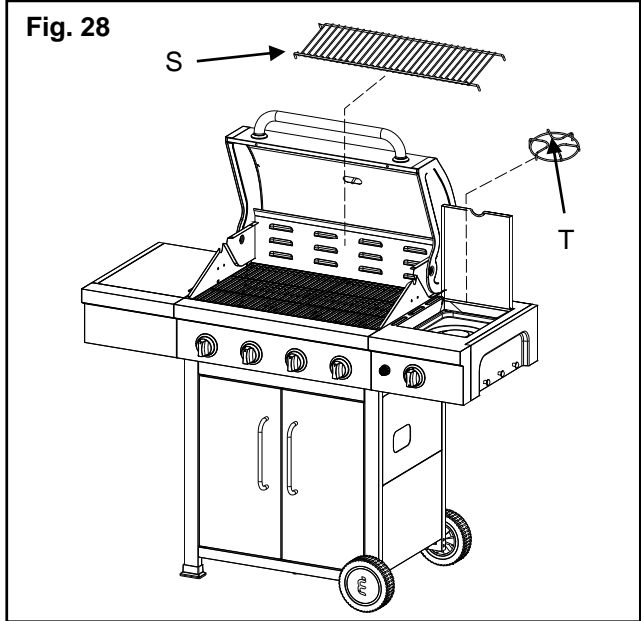

16. Liquid Propane Tank Installation

From rear of grill place the Liquid Propane gas cylinder into the Bottom Panel (B) hole. Then attached the regulator to the Liquid Propane cylinder by turning the regulator handle clockwise. If the outdoor cooking appliance is not in use, the gas must be turned "CLOSED" position at the Liquid Propane Cylinder. As show in Fig.29.



Always keep the LP gas cylinder at 90° (upright) orientation to provide vapor withdraw.

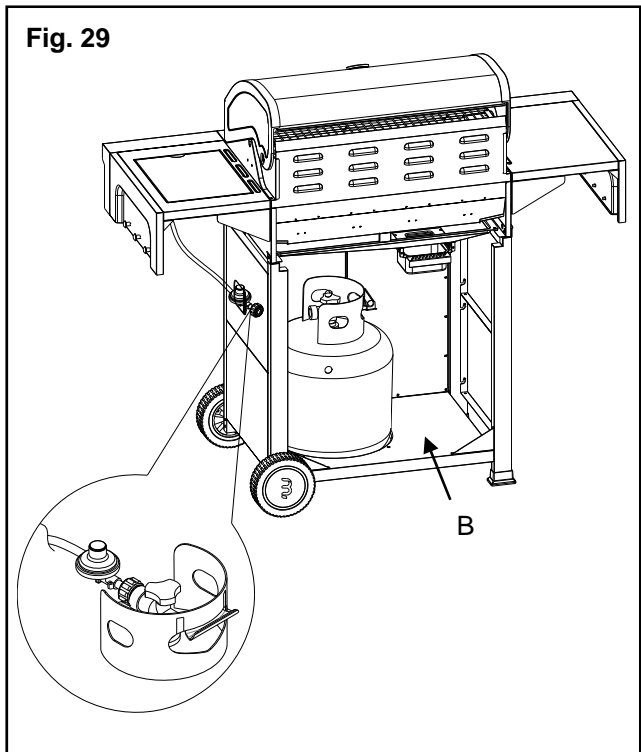

Gas Hook - Up

NEVER CONNECT AN UNREGULATED GAS SUPPLY LINE TO THE APPLIANCE. USE THE REGULATOR/HOSE ASSEMBLY SUPPLIED.

This is a LP gas configured grill. Do not attempt to use a natural gas supply, the grill has not been approved for natural gas use.

Total gas consumption (per hour) with all burners set on "HIGH":

Main burner	48,000 BTU/Hr.
Side burner	12,000 BTU/Hr.
Total	60,000 BTU/Hr.

LP GAS cylinder REQUIREMENT (9kg. Cylinder)

A dented or rusty LP gas cylinder may be hazardous and should be checked by your LP gas supplier. Never use a cylinder with a damaged valve. The LP gas cylinder must be constructed and marked in accordance with the specifications for LP gas cylinders for South Africa.

Storage of an outdoor cooking gas appliance indoor is permissible only if the cylinder is disconnected and removed from the outdoor cooking gas appliance. The cylinder system must be arranged for vapor withdrawal. The cylinder must include a collar to protect the cylinder valve.

Remove the plastic valve cover from the LP gas cylinder. Make sure the grill gas hoses do not contact the grease pan or grill firebox when the LP gas cylinder is placed into the cart.

CONNECTION THE LP GAS CYLINGER

Your grill is equipped with gas supply orifices for use only with LP gas. It is also equipped with a high capacity hose/regulator assembly for connection to a standard 9kg. LP gas cylinder 52cm high, 30cm diameter. To connect the LP gas supply cylinder, please follow the steps below:

1. Make sure cylinder valve is in the complete off position (turn clockwise to stop)
2. Check cylinder valve to ensure it has proper internal female threads.

Regulator Connection

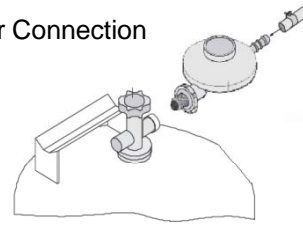

3. Make sure all burner valves are in their off position.
4. Inspect valve connections, port, and regulator assembly. Look for any damage or debris. Remove any debris. Inspect hose for damage. Never attempt to use damaged or obstructed equipment. See your local LP gas dealer for repair.
5. When connecting regulator assembly to the valve, hand tighten the wheel connection anti-clockwise to a complete stop. Do not use a wrench to tighten. Use of a wrench may damage the wheel and result in a hazardous condition.
6. Open the cylinder valve fully (counterclockwise). Apply the soap solution with a clean brush to all gas connections. See below. If growing bubbles appear in the solution the connection is not properly sealed. Check each fitting and tighten or repair if necessary.



7. If you have a gas connection leak you cannot repair, turn gas OFF at supply cylinder, disconnect fuel line from your grill and call (+27) 12 802 1515 or your gas supplier for repair assistance. In case of severe gas leaks or fire, contact your local fire department.
8. Also apply soapy solution to the cylinder seams. See below. If growing bubbles appear, shut cylinder OFF and do not use or move it! Contact an LP gas supplier or your fire department for assistance.

TO DISCONNECT THE LP GAS CYLINGER:

1. Turn the burner valves off.
2. Turn the cylinder valve off fully (turn clockwise to stop).
3. Detach the regulator assembly from the cylinder valve by turning the wheel clockwise.

Installer Final Check List

- ✓ Minimum clearance from sides and back of unit to combustible construction, 24 inches (61cm) from sides and 24 inches (61cm) from back
- ✓ All internal packaging removed.
- ✓ Knobs turn freely.
- ✓ Burners are tight and sitting properly on orifices.
- ✓ Pressure regulator connected and set. Gas connections to grill using hose & regulator assembly provided for 9kg LP gas cylinder.
- ✓ Unit tested and free of leaks.
- ✓ User informed of gas supply shut off valve location.

USER, PLEASE RETAIN THIS MANUAL FOR FUTURE REFERENCE.

LP GAS CYLINDER CAUTIONS

- a) Do Not store a spare LP gas cylinder under or near this appliance.
- b) NEVER fill the cylinder beyond 80 percent full.
- c) If the information in “a” and “b” is not followed exactly, a fire or explosion causing death or serious injury may occur.

Leak Testing

GENERAL

Although all gas connections on the grill are leak tested at the factory prior to shipment, a complete gas tightness check must be performed at the installation site due to possible mishandling in shipment, or excessive pressure unknowingly being applied to the unit. Periodically check the whole system for leaks following the procedures listed below. If the smell of gas is detected at anytime you should immediately check the entire system for leaks.

BEFORE TESTING

Make sure that all packing material is removed from the grill including tie-down straps.

**DO NOT SMOKE WHILE LEAK TESTING.
NEVER PERFORM LEAK TEST WITH AN OPEN FLAME.**

Make a soap solution of one part liquid detergent and one part water. You will need a spray bottle, brush, or rag to apply the solution to the fittings. For the initial leak test, make sure the LP gas cylinder is 80% full.

TO TEST

1. Make sure the control valves are in the “OFF” position, and turn on the gas supply.
2. Check all connections from the LP gas regulator and supply valve up to and including the connection to the manifold pipe assembly (the pipe that goes to the burners). Soap bubbles will appear where a leak is present.
3. If a leak is present, immediately turn off the gas supply and tighten the leaky fittings.
4. Turn the gas back on and recheck.
5. Should the gas continue to leak from any of the fittings, turn off the gas supply and contact customer service at (+27) 12 802 1515 .

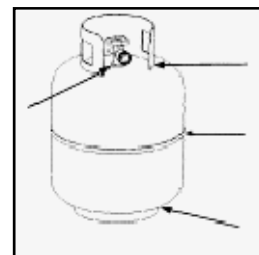

Only those parts recommended by the manufacturer should be used on the grill.

Substitution will void the warranty. Do not use the grill until all connections have been checked and do not leak.

GAS FLOW CHECK

Each grill burner is tested and adjusted at the factory prior to shipment; however, variations in the local gas supply may make it necessary to adjust the burners. The flames of tips, excessive noise or lithe burners should be visually checked.

Flames should be blue and stable with no yellow. If any of these conditions exist, check to see if the air shutter or burner ports are blocked by dirt, debris, spider webs, etc. If you have any questions regarding flame stability, please call customer service (+27) 12 802 1515 .

ALWAYS CHECK FOR LEAKS AFTER EVERY LP GAS CYLINDER CHANGE

Check all gas supply fittings for leaks before each use. It is handy to keep a spray bottle of soapy water near the shut-off valve of the gas supply line. Spray all the fittings. Bubbles indicate leaks.

CAUTIONS

Place dust cap on cylinder valve outlet when the cylinder is not in use. Only install the type of dust cap on the cylinder valve outlet that is provided with the cylinder valve. Other types of caps or plugs may result in leakage of LP gas .

The gas must be turned off at the supply cylinder when the unit is not in use.

If the appliance is stored indoors the cylinder must be disconnected and removed from the appliance. Cylinders must be stored outdoors in a well-ventilated area out of the reach of children

Your grill is ready to use!

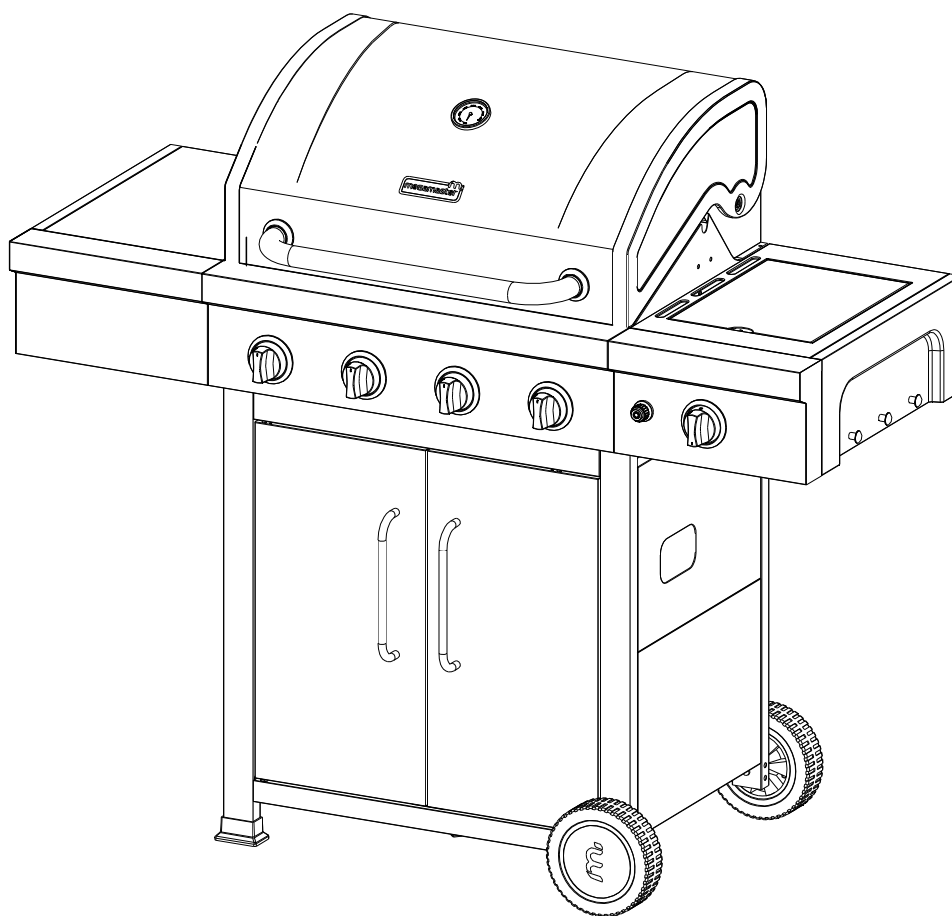

Operating Instructions

GENERAL USE OF THE GRILL

Each main burner is rated at 13,500 Btu/hr. The main grill burners encompass the entire cooking area and are side ported to minimize blockage from falling grease and debris. The igniter knobs are located on the lower center portion of the valve panel. Each rotary igniter is labeled on the control panel.

USING THE GRILL

Grilling requires high heat for searing and proper browning. Most foods are cooked at the "HIGH" heat setting for the entire cooking time. However, when grilling large pieces of meat or poultry, it may be necessary to turn the heat to the lower setting after the initial browning. This cooks the food through without burning the outside. Foods cooked for a long time or foods basted with a sugary marinade may need the lower heat setting near the end of the cooking time.

NOTE: This barbecue unit is designed to grill efficiently without the use of lava rocks or briquettes of any kind. Heat is radiated by the stainless steel flame tamers positioned above each burner.

NOTE: The hot grill sears the food, sealing in the juices. The more thoroughly the grill is preheated, the faster the meat browns and the darker the grill marks.

DO NOT LEAVE THE GRILL UNATTENDED WHILE COOKING.

Grill Lighting Instructions

WARNING: IMPORTANT! BEFORE LIGHTING...

Inspect the gas supply hose prior to turning the gas "ON". If there is evidence of cuts, wear, or abrasion, it must be replaced prior to use. Do not use the grill if the odor of gas is present. Do not use any other hose connection other than the regulator hose assembly that came with the unit.

Never substitute regulators and hose assembly for those supplied with the grill. If a replacement is necessary, contact the manufacturer for proper replacement. The replacement must be specified in the owners manual.

WARNING: Always keep your face and body as far away from the burner as possible when lighting.

TO LIGHT THE MAIN BURNER

Make sure all knobs are "OFF" then turn on the gas supply from the LP gas cylinder. Always keep your face and body as far from the grill as possible when lighting.

Your grill has an exclusive patented built-in ignition. The igniter is battery operated. To ignite each burner simply push and turn the control knobs to the HI setting, you will hear gas flow through. Press and hold the Ignitor button until burner ignites.

Grill Lighting Instructions *continued*

FLAME CHARACTERISTICS

Check for proper burner flame characteristics.

Burner flames should be blue and stable with no yellow tips, excessive noise, or lifting. If any of these conditions exist call our customer service line. If the flame is yellow, this is a indication of insufficient air. If the flame is noisy and tends to lift away from the burner, this is a indication of excessive oxygen.

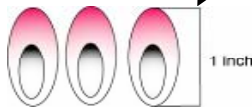
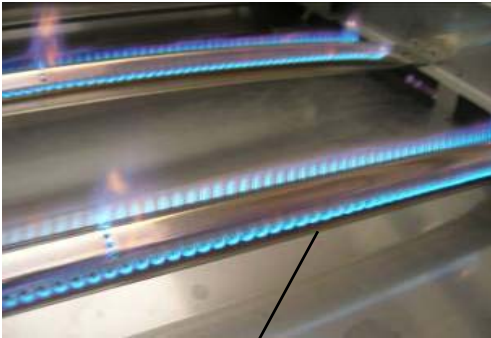

Visually check the burner flames prior to each use. The flames should look like this picture, if they do not, refer to the burner maintenance part of this manual.

Each burner is adjusted prior to shipment; however, variations in the local gas supply may make minor adjustments necessary.

Lighting Instructions

Note: Remove all packaging, including straps, before using the grill

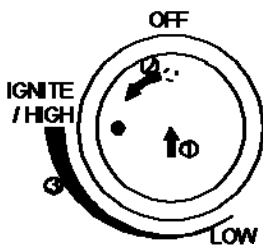
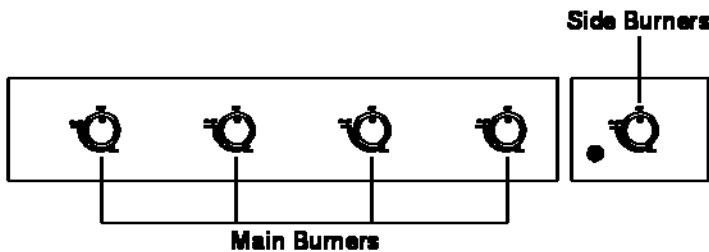

**ELECTRONIC
IGNITION BUTTON**



1. Open lid during lighting.
2. Make sure all the knobs are in the "OFF" position, and then turn the Liquid Propane Cylinder valve "ON" by slowly turning counterclockwise.
3. Push and turn Main Burner control knob to IGNITE/HIGH, at the same time, press and hold electronic ignition button to light the burner.
4. Once the burner is lit, release the electronic ignition button and knob.
5. If ignition does not occur in 5 seconds, turn the knob to OFF, wait 5 minutes and repeat the lighting procedure or light by match.

Care and Maintenance

STAINLESS STEEL

There are many different stainless steel cleaners available. Always use the mildest cleaning procedure first, scrubbing in the direction of the grain. Specks of grease can gather on the surfaces of the stainless steel and bake on to the surface and give the appearance of rust. For removal use a mild abrasive pad in conjunction with a stainless steel cleaner.

GRILL GRATE

The easiest way to clean the grill is immediately after cooking is completed and after turning off the flame. Wear a barbecue mitt to protect your hand from the heat and steam. Dip a brass bristle barbecue brush in water and scrub the hot grill. Dip the brush frequently in the bowl of water. Steam, created as water contacts the hot grill, assists the cleaning process by softening any food particles. If the grill is allowed to cool before cleaning, cleaning will be more difficult.

ENSURE THAT THE GAS SUPPLY AND THE KNOBS ARE IN THE "OFF" POSITION. MAKE SURE THE RANGETOP BURNER IS COOL BEFORE REMOVAL.

GRILL BURNERS

Extreme care should be taken when moving a burner as it must be correctly centered on the orifice before any attempt is made to relight the grill. Frequency of cleaning will depend on how often you use the grill.

MAIN GRILL BURNER CLEANING

Ensure the gas supply is off and the knobs are in the "OFF" position. Make sure the grill is cool. Clean the exterior of the burner with a wire brush. Remove excessive build up with a metal scraper. Clear any clogged ports with a straightened paper clip. Never use a wooden toothpick as it may break off and clog the port. Please note if insects or other obstructions are blocking the flow of gas through the burner, and if so you will need to call your local gas supplier.

GREASE TRAY CLEANING

The grease tray should be emptied and wiped down periodically and washed with a mild detergent and warm water solution. A small amount of sand may be placed in bottom of grease tray to absorb the grease. Check the grease tray frequently, do not allow excess grease to accumulate and overflow out of the grease tray.

BURNER CLEANING

1. Turn off the gas supply, and make sure all the knobs are in the "OFF" position.
2. Wait for the grill to cool.
3. Clean the exterior of the burner with a wire brush. Use a metal scraper to stubborn stains.
4. Clear clogged port with a straightened paper clip. Never use a wooden toothpick as it may break off and clog the port.
5. If inserts or other obstructions are blocking the flow of gas through the burner, call customer service at +27 12 802 1515

Warning: If you wish to replace main burner, we strongly recommend that you hire a professionally trained technician to replace it. Please understand that we will not be responsible for any liability, personal injury, or property damage resulting from an improperly assembled burner.

HOW TO REPLACE MAIN BURNER

Step 1. Insert the burner onto the orifice. As show below, make sure burner hole aim at orifice .



Step 2. Secure the main burner on the back wall of fire box with 1 Pin and secure it at the front of fire box with 1 screw.



CAUTION

1. Keep outdoor cooking gas appliance area clear and free from combustible materials, gasoline and other flammable vapors and liquids.
2. Do not obstruct the flow of combustible and ventilation air.
3. Keep the ventilation openings of the cylinder enclosure free and clear from debris.

Trouble Shooting

SPIDER AND INSECT WARNING

Checking and cleaning burner/ venturi tubes for insects and insect nests. A clogged tube can lead to a fire beneath the grill.

Spiders and small insects occasionally spin webs or make nests in the grill burner tubes during transit and warehousing. These webs can lead to gas flow obstruction which could result in a fire in and around burner tubes. This type of fire is known as "BURN-BACK" and can cause serious damage to your grill and create an unsafe operating condition for the user.

Although an obstructed burner tube is not the only cause of "BURN-BACK", it is the most common cause.

To reduce the chance of "BURN-BACK", you must clean the burner tubes before assembling your grill, and at least once a month in late summer or early fall when spiders are most active. Also perform this burner tube cleaning procedure if your grill has not been used for an extended period of time.

WHEN TO LOOK FOR SPIDERS

You should inspect the burners at least once a year or immediately after any of the following conditions occur:

1. The smell of gas in conjunction with the burner flames appearing yellow.
2. The grill does not reach temperature.
3. The grill heats unevenly.
4. The burners make popping noises.

BEFORE CALLING FOR SERVICE

If the grill does not function properly, use the following check list before contacting your dealer for service. You may save the cost of a service call.

PREHEATING: The grill lid should be in a closed position during the preheat time period. It is necessary to preheat the grill before cooking certain foods, depending on the type of food and the cooking temperature. Food that requires a high cooking temperature needs a pre-heat period of five minutes; food that requires a lower cooking temperature needs only a period of two to three minutes.

COOKING TEMPERATURES

High setting-Use this setting for fast warm-up, for searing steaks and chops, and grilling.

Low setting-Use this setting for all roasting, baking, and when cooking very lean cuts such as fish.

These temperatures may vary with the outside temperature and the amount of wind.

Cooking with in-direct Heat: You can cook poultry and large cuts of meat slowly to perfection on one side of the grill by indirect heat from the burner on the other side. Heat from the lighted burner circulates gently throughout the grill, cooking the meat or poultry without any direct flame touching it. This method greatly reduces flare-ups when cooking extra fatty cuts, because there is no direct flame to light the fats and juices that drip down during cooking.

CAUTION: If burners go out during operation, close gas supply at source, and turn all gas valves off. Open lid and wait five minutes before attempting to re-light (this allows accumulated gas fumes to clear).

CAUTION: Should a grease fire occur, close gas supply at source, turn off all burners and leave lid closed until fire is out.

CAUTION: DO NOT attempt to disconnect any gas fitting while your grill is in operation. As with all appliances, proper care and maintenance will keep appliances in top operating condition and will prolong the life of the appliance. Your gas grill is no exception.

Trouble Shooting

continued

PROBLEM	SOLUTION
When attempting to light my grill, it will not light immediately.	Make sure you have a spark while you are trying to light the burner (if no spark) Ensure that the wire is connected to the electrode assembly. Clean wire (s) and / or electrode with rubbing alcohol and a clean swab. Wipe with a clean cloth. Check to see if the other burners operate. If so. Check the gas orifice on the malfunctioning burner for an obstruction.
Regulator makes noise.	Vent hose on the regulator may be plugged or regulator may be faulty. Ensure the vent hole on the regulator is not obstructed. Clear the hole, close the gas control valves. Wait ten minutes and re-start. Check your flames for proper performance. If the flames are not correct, replace regulator.
Grill only heats to 200-300 degrees.	Check to see if the fuel hose is bent or kinked. Make sure the grill area is clear of dust. Make sure the burner and orifices are clean. Check for spiders and insects. The regulator has a safety device that restricts the flow of gas in the event of a leak. This safety device can be triggered without a gas leak. To reset the safety device, turn off all burners and close the LP cylinder valve. Disconnect the regulator from the LP cylinder and wait one minute. Reconnect the regulator to the LP cylinder and slowly open the LP cylinder valve until the valve is fully open. Light all burners and observe the temperature.
Grill takes a long time to preheat.	Normal preheat 500-600 degrees, takes about 10-15 min. Cold weather and wind may effect your preheat time. If you are using volcanic rock or briquettes they can increase the preheat time and maximum temperature.
Burner flames are not light blue.	Too much or not enough air for the flame. Elevation is the principal cause, however cold weather can affect the mixture. Burner adjustment may be required. Grill is in a windy location.

Grill Cooking Chart

WARNING: To ensure that it is safe to eat, food must be cooked to the minimum internal listed in the table below.

USDA* Safe Minimum Internal Temperatures	
Fish	65 °C
Pork	70 °C
Egg Dishes	70 °C
Steaks and Roasts of Beef, Veal or Lamb	65 °C
Ground Beef, Veal or Lamb	70 °C
Whole Poultry (Turkey, Chicken, Duck, etc.)	75 °C
Ground or Pieces Poultry (Chicken Breast, etc.)	75 °C

*United States Department of Agriculture

FOOD	Weight or thickness	Temperature	Time	Special instructions and tips
Vegetables	NA	Medium	8 to 20 minutes	Slice or chop vegetables and dot with butter or margarine. Wrap tightly in heavy duty foil. Grill turning occasionally.
Potatoes	Whole	Medium	40 to 60 minutes	Wrap individually in heavy duty foil. Cook rotating occasionally.
Meat/Steaks	1/2 to 3/4 inches	High-Medium	4 to 15 minutes	Pre heat grill for 15-20 minutes then sear steaks on each side for two minutes. Next grill 3 to 5 minutes on each side or until desired doneness.
Ground Meats	1/2 to 3/4 inches	Medium	8 to 15 minutes	Grill turning once when juices rise to the surface or until desired amount of doneness. Do not leave hamburgers unattended since a flare-up could occur quickly.
Ribs	1/2 or full rack	Medium	20 to 40 minutes	Grill turning occasionally. During last few minutes brush with barbecue sauce, turn several times.
Hot dogs	NA	Medium	5 to 10 minutes	Grill turning four times. 2-4 minutes on each of four sides.
Poultry-Cut	1/4 to 1/2 pounds	Low or Medium	20 to 40 minutes	Grill turning occasionally. During last few minutes brush with barbecue sauce if desired, turn several times.
Poultry Whole	2 to 3 pounds	Low or	1 to 1-1/2 hours	Use poultry stand and brush frequently as desired
		Medium	40 to 60 minutes	Use poultry stand and brush frequently as desired
Fish	3/4 to 1 inch	Medium	8 to 15 minutes	Grill turning once to desired doneness. Brush with melted butter, margarine or oil.

Limited Warranty

This grill has a one (1) year limited warranty.

The warranty period is valid from the date of purchase.

This is subject to correct assembly, use, storage and regular maintenance of the product.

Please refer to page 12 and 13 of this manual for list of replacement parts.

Please Note: the main burner has a warranty of three (3) years. This is subject to regular cleaning and correct maintenance of the burner.

This product is intended for use with a 9kg LP Gas Cylinder, use of any other cylinder any resulting damage to the product will void the warranty.

This product is intended for use with the supplied low pressure, 2.8kPa LP gas regulator, use with any other type of pressure regulator and any resulting damage to the product will void the warranty.

It is the responsibility of the product owner to safely store and protect the grill from the elements; covers can be purchased separately to protect this product.

This warranty does not cover the following:

- Rust
- Corrosion
- Discolouration

Please contact our customer service department for any further explanation at +27 12 802 1515.



Blaze 400 Elite Red

PATIO GAS BRAAI

FOR OUTDOOR USE ONLY

 **WARNING**

Read and follow all Safety, Assembly, and Use & Care Instructions in this guide before assembling and cooking with this grill.

Failure to follow all instructions in this Use & Care Guide may lead to fire or explosion, which could result in property damage, personal injury or death.

This appliance complies with the requirements of SANS 1539

www.megamaster.co.za