

ALFA



MODERNO 3 PIZZE

Data Sheets - Scheda Tecnica



ANTIQUE RED

FXMD-3-LROA

ARDESIA GREY

FXMD-3-LGRA

FIRE YELLOW

FXMD-3-LGIA

Weight Peso	97 kg 214 lbs	Materials Materiali	Stainless Steel, iron sheet, Ceramic fiber Acciaio inox, lamiera ferro, Fibroceramica
Cooking floor Piano Cottura	90x50 cm 35 x 20 in	Type of refractory Tipo di refrattario	Alumina silicate HeatKeeper™ Firebrick Tavella HeatKeeper™ silico-alluminoso
Max oven temperature Temperatura massima	500°C 1000°F	Recommended fuel Combustibile consigliato	WOOD - Max 2 in diam. logs. trimmings LEGNA - Ciochi diametro Max 5 cm potature
Heating time Minuti per scaldare	30'	Minimum flue draught Tiraggio minimo	11 Pa
Pizza capacity Numero Pizze	3 Pizza Ø30cm	Flue smokes mass flow Flusso volumetrico fumi	49.6 g/s
Rated charge Carica Nominale	8.3 kg/h 18.3 lbs/h	Average consumption Consumo Medio	2 kg/h 4.4 lbs/h
Smoke temperature Temperatura fumi	395°C 743°F	CO emission at 13% O₂ Emissioni CO al 13% O ₂	0.35% 4444 mg/Nm³



made in Italy

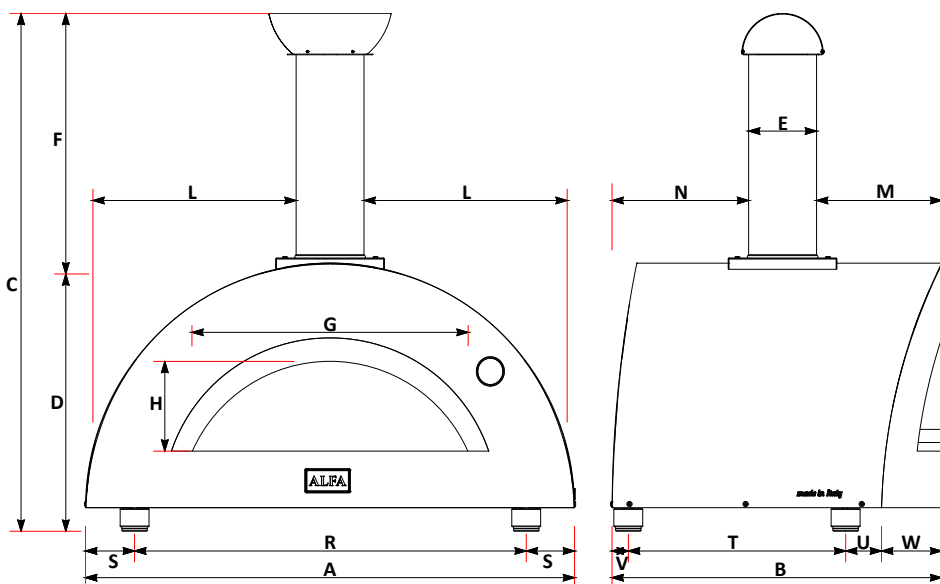

	cm	inch		cm	inch
A	108	42,5	N	30,1	11,9
B	72,8	28,7	O	37,6	14,8
C	114	44,9	P	21,9	8,6
D	60,3	23,7	Q	54	21,3
E	15	5,9	R	86,5	34,1
F	54	21,3	S	10,8	4,3
G	61	24,0	T	48	18,9
H	20	7,9	U	7,95	3,1
L	46,5	18,3	V	3,5	1,4
M	27,7	10,9	W	13,3	5,2

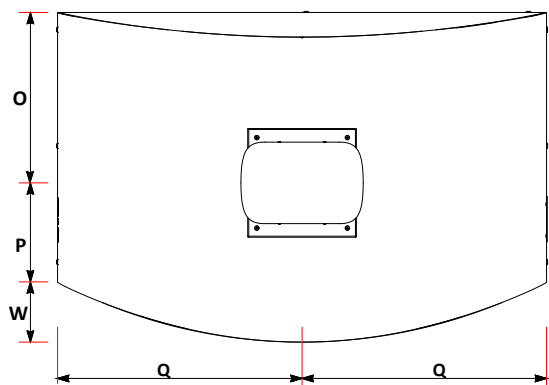

PACKAGING				
DIMENSIONE IMBALLO				
	Width Larghezza	Depth Profondità	Height Altezza	Weight Peso
cm	114	91	72,5	kg 107
inch	45	35,8	28,5	lbs 236

Description Descrizione	Code Codice
Chimney cap Comignolo	A CMG-1-012
Chimney Canna fumaria	B TI150_480_SAT
Door Sportello	C SPT-1-012
Flange Flangia	D FLG-2-009
External shell Carter esterno	E CRT-1-025
Thermometer Termometro	F YT63-135
Red bricks 30x20 cm Mattoni 30x20 cm	G RRA3020
Feet (n.4) Piedini	H SETPIE-M10X20
Logo Alfa (v1.0)	I D14PLAC-ALFA



ALFA



MODERNO 3 PIZZE

Data Sheets - Scheda Tecnica



ANTIQUE RED

FXMD-3-GROA

ARDESIA GREY

FXMD-3-GGRA

FIRE YELLOW

FXMD-3-GGIA

Weight Peso	97 kg 214 lbs	Materials Materiali	Stainless Steel, iron sheet, Ceramic fiber Acciaio inox, lamiera ferro, Fibroceramica	
Cooking floor Piano Cottura	80x50 cm 31 x 20 in	Type of refractory Tipo di refrattario	Alumina silicate HeatKeeper™ Firebrick Tavella HeatKeeper™ silico-alluminoso	
Max oven temperature Temperatura massima	500°C 1000°F	Recommended fuel Combustibile consigliato	LPG gas (G30 / G31) Gas GPL (G30 / G31)	Natural Gas (G20) Gas Metano (G20)
Heating time Minuti per scaldare	30'	Gas category Categoria gas	I3+ GPL	I2H (METANO)
Pizza capacity Numero Pizze	3 Pizza Ø30cm	Operation Funzionamento	28..30 / 37 mbar 11 in WC	20 mbar 4 in WC
Heat capacity Potenza nominale	18 kW 61.418 Btu/h	Max consumption Consumo Massimo	1.57 kg/h	2.07 m³/h



made in Italy

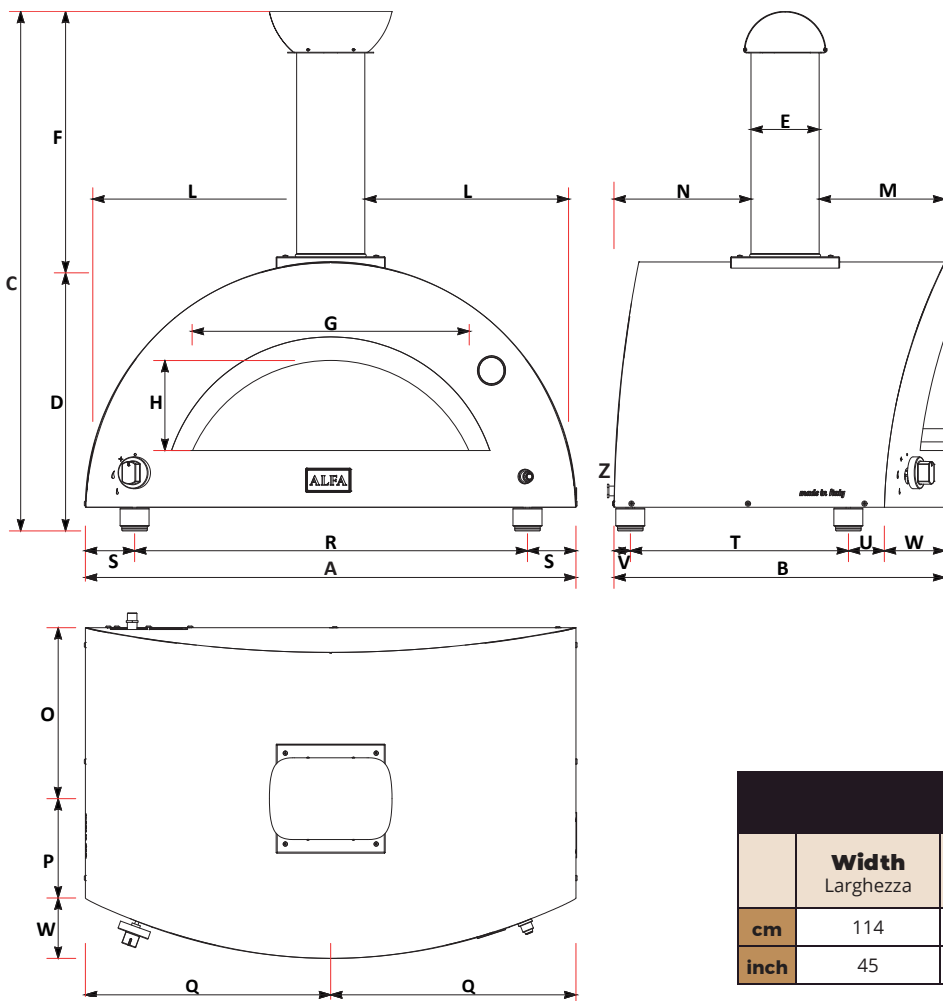

	cm	inch		cm	inch
A	108	42,5	N	30,1	11,9
B	72,8	28,7	O	37,6	14,8
C	114	44,9	P	21,9	8,6
D	60,3	23,7	Q	54	21,3
E	15	5,9	R	86,5	34,1
F	54	21,3	S	10,8	4,3
G	61	24,0	T	48	18,9
H	20	7,9	U	7,95	3,1
L	46,5	18,3	V	3,5	1,4
M	27,7	10,9	W	13,3	5,2

Z A minimum of 10 cm (4 in) must be considered to connect the oven to the gas source.
 E' necessario prevedere un minimo di 10 cm per collegare il forno al gas.

PACKAGING DIMENSIONE IMBALLO				
	Width Larghezza	Depth Profondità	Height Altezza	Weight Peso
cm	114	91	72,5	kg 107
inch	45	35,8	28,5	lbs 236

Description Descrizione	Code Codice
Chimney cap Comignolo	A CMG-1-012
Chimney Canna fumaria	B TI150_480_SAT
Door Sportello	C SPT-1-012
Flange Flangia	D FLG-2-009
External shell Carter esterno	E CRT-1-018
Thermometer Termometro	F YT63-135
Red bricks 30x20 cm Mattoni 30x20 cm	G RRA3020
Feet (n.4) Piedini	H SETPIE-M10X20
Logo Alfa (v1.0)	I D14PLAC-ALFA
KIT GAS 24kW	L GAS-1-009
Gas knob Manopola gas	M D14MANO-70P
Electric generator Generatore elettrico	N GENELP003IQ
Electrical cable Cavo elettrico	N D14CAVOTV-1500
Side gas cover Carter laterale gas	O CRT-2-028

