



19 BAR ESPRESSO MAKER

Instruction Manual





TABLE OF CONTENTS

Important Safeguards	2-3
Additional Important Safeguards.....	4-5
Notes on the Plug	6
Notes on the Cord.....	6
Plasticizer Warning	7
Electric Power.....	7
The Art of Extracting Espresso and Texturing Milk.....	7
Getting to Know Your Bella Pro 19 Bar Espresso Maker.....	8-10
Safety Warnings	11
Before Using for the First Time	12-13
Filter Baskets: Pressurized or Non-Pressurized?	14
Pull the Perfect Espresso Shot.....	15-16
Dial In Single or Double Shot Volume	17
Texture Milk for Espresso Drinks.....	17-18
User Maintenance Instructions.....	18
Care & Cleaning Instructions	18-19
Descaling	20
Storing Instructions.....	21
Trouble Shooting	22-23
Bella Pro Espresso Recipes	24-25
Warranty	26-27

IMPORTANT SAFEGUARDS

When using electrical appliances, basic safety precautions should always be followed, including the following:

- 1. READ ALL INSTRUCTIONS BEFORE USING.**
2. Do not touch hot surfaces. Use handles or knobs.
3. When in use, the appliance is under pressure and should never be left unattended.
4. To protect against fire, electric shock and injury to persons, do not place cord, plugs, or appliance in water or other liquid.
5. This appliance is not intended for use by persons (including children) with reduced physical, sensory or mental capabilities, or lack of experience and knowledge, unless they have been given supervision or instruction concerning use of the appliances by a person responsible for their safety.
6. Close supervision is necessary when any appliance is used by or near children.
7. Unplug from outlet when not in use and before cleaning.
8. Allow Espresso Maker to cool before putting on or taking off parts, and before cleaning the appliance.
9. Do not operate any appliance with a damaged cord or plug or after the appliance malfunctions, or has been damaged in any manner. Contact Consumer Service for examination, repair or adjustment.

- 
- 
- 
10. The use of any accessory not evaluated for use with this appliance and not recommended by the appliance manufacturer may cause fire, electric shock or injuries to persons.
 11. Do not use outdoors.
 12. Do not let cord hang over edge of table or counter, or touch hot surfaces.
 13. Do not place on or near a hot gas or electric burner, or in a heated oven.
 14. If this appliance begins to malfunction during use, press the POWER button; turn the function control to STAND BY. Then immediately unplug the cord. Do not use or attempt to repair the malfunctioning appliance.
 15. Never use the appliance without water.
CAUTION: Relieve pressure through steam wand before removing cup or filter basket.
 16. Do not use appliance for other than intended use.
 17. Be certain lids are securely in place before operating appliance.
 18. Scalding may occur if the lids are removed during the brewing cycle.
 19. To disconnect, turn any control to “off”, then remove plug from wall outlet.
 20. **WARNING:** To avoid the risk of injury, do not open the brew chamber during the brew process.

SAVE THESE INSTRUCTIONS

**THIS PRODUCT IS FOR
HOUSEHOLD USE ONLY**

ADDITIONAL IMPORTANT SAFEGUARDS

WARNING: This appliance generates heat and escaping steam during use. Proper precautions must be taken to prevent the risk of burns, fires, or other injury to persons or damage to property.

CAUTION: The Espresso Maker must be allowed to cool down sufficiently before adding more water to avoid splattering.

1. All users of this appliance must read and understand this instruction manual before operating or cleaning this appliance.
2. The cord to this appliance should be plugged into a 120V AC electrical outlet only.
3. Use water only in this appliance! Do not put any other liquids or food products in this appliance. Do not mix or add anything to the water placed in this appliance, except as instructed in the Descaling section of this instruction manual.
4. DO NOT attempt to move an appliance containing hot liquids. Allow appliance to cool completely before moving.
5. Keep appliance at least 4 inches away from walls or other objects during operation.
6. Place the appliance on a surface that is resistant to heat.
7. Prior to connecting or disconnecting plug from wall outlet, press the POWER button; turn the function control to STAND BY.

- 
8. If this appliance falls or accidentally becomes immersed in water or any other liquid, unplug it immediately. **DO NOT REACH INTO THE WATER!** Do not use this appliance after it has fallen into or has become immersed in water. Contact Consumer Service for examination and repair.
 9. Always use fresh, cool water in your appliance. Warm water or other liquids, except as described in the Descaling section, may cause damage to the Espresso Maker.

NOTES ON THE PLUG

This appliance has a polarized plug (one blade is wider than the other). To reduce the risk of electric shock, this plug will fit in a polarized outlet only one way. If the plug does not fit fully into the outlet, reverse the plug. If it still does not fit, contact a qualified electrician. Do not modify the plug in any way.

NOTES ON THE CORD

- A. A short power-supply cord is to be provided to reduce risks resulting from becoming entangled in or tripping over a longer cord.
- B. Longer detachable power-supply cords or extension cords are available and may be used if care is exercised in their use.
- C. If a long detachable power-supply cord or extension cord is used:
 - 1. The marked electrical rating of the detachable power-supply cord or extension cord should be at least as great as the electrical rating of the appliance;
 - 2. If the appliance is of the grounded type, the extension cord should be a grounding- type 3-wire cord; and
 - 3. The longer cord should be arranged so that it will not drape over the counter top or table top where it can be pulled on by children or tripped over.

ELECTRIC POWER

If the electrical circuit is overloaded with other appliances, your appliance may not operate properly. It should be operated on a separate electrical circuit from other appliances.

PLASTICIZER WARNING

CAUTION: To prevent Plasticizers from migrating to the finish of the counter top or table top or other furniture, place **NON-PLASTIC** coasters or place mats between the appliance and the finish of the counter top or table top. Failure to do so may cause the finish to darken; permanent blemishes may occur or stains can appear.

THE ART OF EXTRACTING ESPRESSO AND TEXTURING MILK

Whether you are an experienced coffee artisan and interested in latte art or a novice to espresso and just want to relax and enjoy a perfect espresso drink, the Bella Pro 19 Bar Espresso Maker delivers!

Consistency is key when it comes to a good shot of espresso. Optimal espresso flavor is achieved as the brewing temperature is maintained. Grounds are pre-infused with low, steady water pressure before extraction. Shot volumes are automatically dispensed and can be adjusted to taste. The result is a perfectly balanced, rich and flavorful espresso topped with deliciously fine crema. With the Bella Pro 19 Bar Espresso maker, you can create fine microbubbles using the steam wand to top any of your espresso based beverages.

Getting to Know Your Bella Pro 19 Bar Espresso Maker

Product may vary slightly from illustration

Figure 1

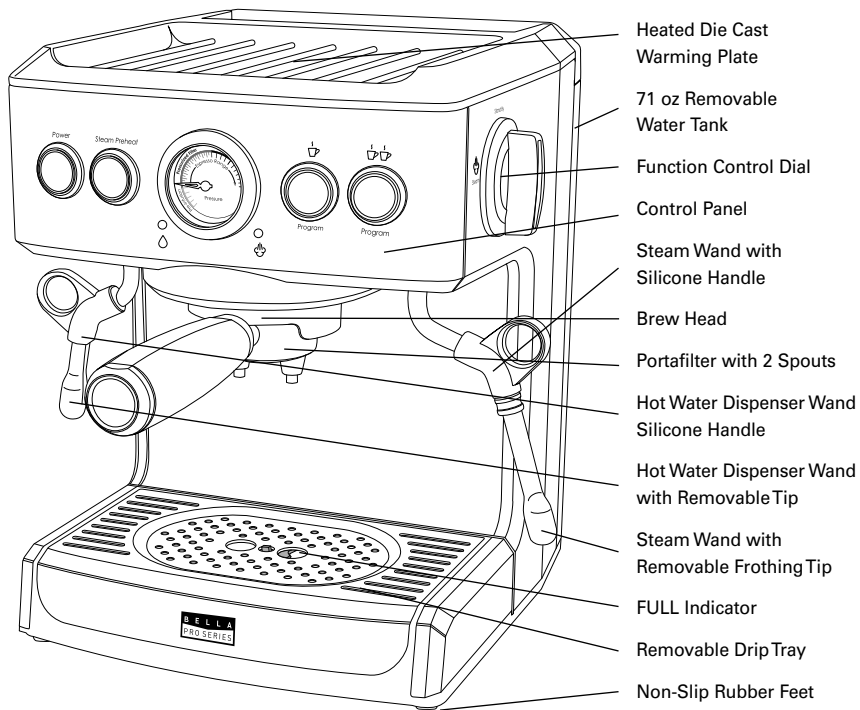

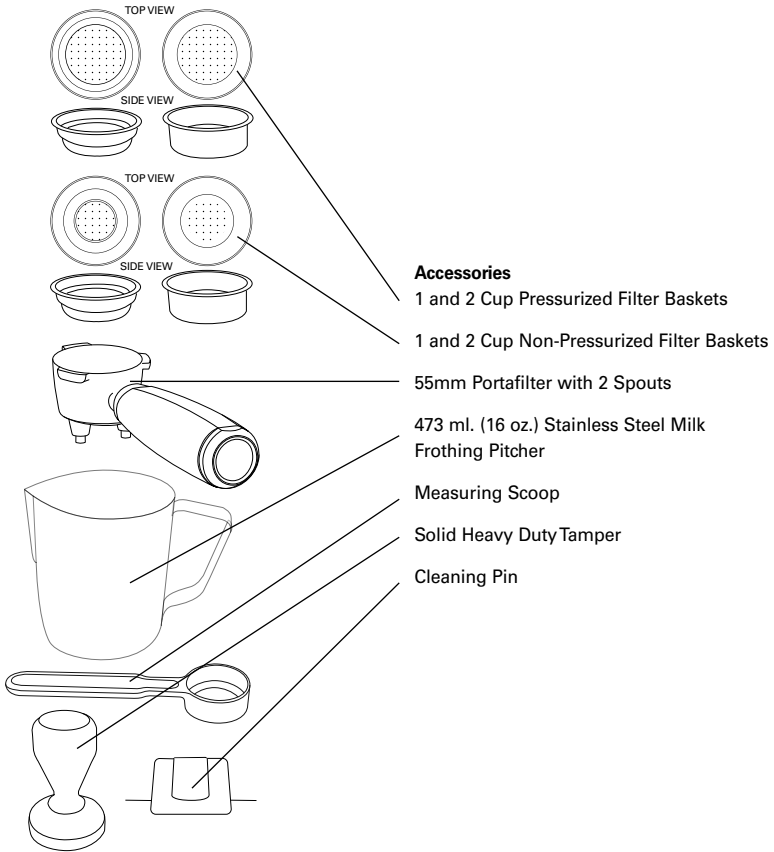

Accessories

1 and 2 Cup Pressurized Filter Baskets

1 and 2 Cup Non-Pressurized Filter Baskets

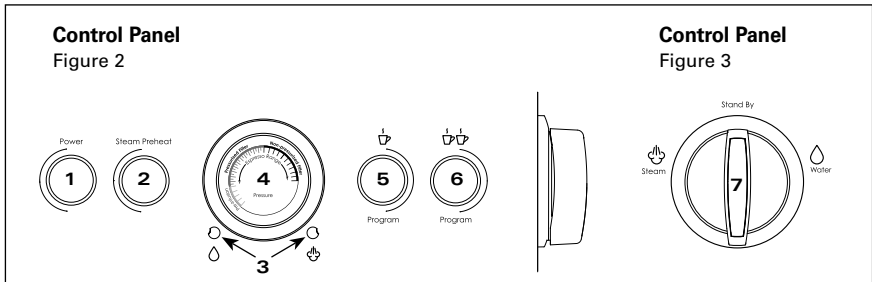

1. **POWER Button.** Press to turn the Espresso Maker ON. The single shot (☕) and double shot (☕☕) buttons will begin to flash. When the system is up to temperature, all 4 buttons on the control panel will illuminate.
2. **STEAM PREHEAT Button.** After espresso shots have been pulled, press to activate the heater to texturize milk. When pressed, the STEAM PREHEAT button will flash. As temperature is achieved and steam is built, the button will illuminate.
3. **Water / Steam Indicator Lights.** As the water dispenser is activated, the water indicator light will flash. The steam indicator light will illuminate as the pressure is directed to the steam wand.
4. **19 Bar Pressure Gauge.** Displays pre-infusion to espresso pressure range.
5. **Single Shot Programmable Button.** Press once to initiate a 2 oz. extraction. Press and hold the button for 3 seconds to adjust and dial in future single shot volume.
6. **Double Shot Programmable Button.** Press once to initiate a 4 oz. extraction. Press and hold the button for 3 seconds to adjust and dial in future double shot volume.
7. **Function Control Dial.** Once pressure is built and the PREHEAT button is illuminated (stops flashing), turn the dial to activate the STEAM wand.

Safety Warnings

- Proper precautions must be made to avoid burns from sprays of hot water or steam.
- Always use the silicone covers and tabs installed on both the steam wand and the water dispenser to rotate and swing either wand to the perfect position.
- Avoid touching any hot surfaces on the machine or any metal parts of the portafilter, filter basket, water dispenser or steam wand while the Espresso Maker is in use or after it has just been used to prepare hot beverages.
- When too much water has accumulated in the drip tray, the red FULL indicator will rise. (See Figure 4.) To avoid water spillage, lift the drip plate off the tray. Slide the drip tray straight out to remove. Empty water, wipe dry, and reassemble. (See Figure 5.)

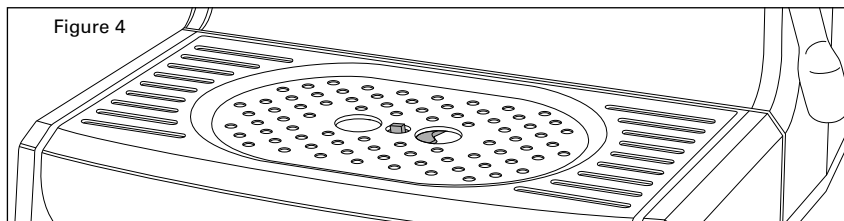



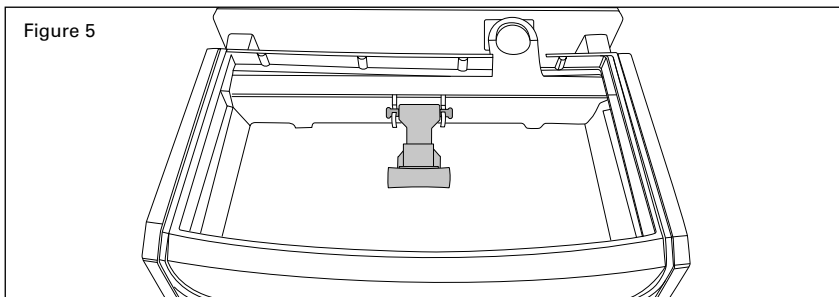

Before Using for the First Time

1. Remove any packaging materials before use. Make sure the Espresso Maker is unplugged.
2. Assemble the Drip Tray. Slide the drip tray in or out to remove for easy cleaning.
3. Line the circular cutout of the FULL bar with the base of the unit; left and right ends should fit snugly in place. (See Figure 5.) Add the drip plate.

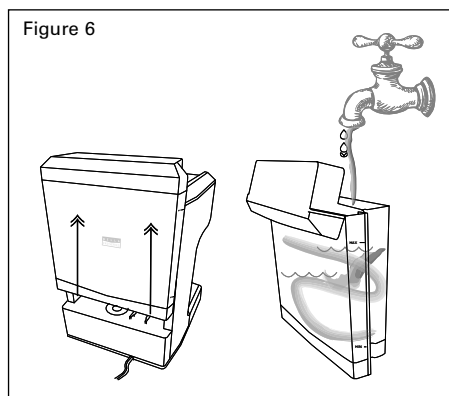

4. **Fill the Water Tank.** Lift and flip open the lid of the water tank and fill with cold water, or... grasp the water tank at the back of the Espresso Maker and lift it up and off the unit. (See Figure 6.)
5. Fill the water tank with cold water to the MAX (2.1 liter) mark.
6. Slide the water tank back to its original position. Lift the lid to close.
7. **Pre-Clean and Prime the Pump.** Place the Espresso Maker on a level surface, within close proximity to a sink to discard water.



8. Place any empty **(do not add coffee)** 2-cup filter basket into the portafilter. Insert and lock into the brew head following the detailed description in the section: "Pulling the Perfect Espresso Shot." (See Figures 8 and 9.)
9. Center a wide-mouth spouted container or cup under the 2-spout portafilter. Place the steam wand's tip into the frothing jug. Place an empty container under the water dispenser.
10. Plug the unit into a 120V AC electrical outlet.
11. Press the POWER button. The single shot () and double shot () buttons will begin to flash. When the system is up to temperature, all 4 buttons on the control panel will illuminate.
12. PRESS THE STEAM PREHEAT button, it will begin to flash until the temperature is reached. Turn the function control dial to STEAM the steam indicator light will illuminate as the hot steam purges the line. After MAX 45 seconds, turn the function control dial back to STAND BY.
13. Turn the function control dial to WATER. Allow water to fill the container, then discard. Turn the function control dial to STAND BY.
14. Press the double shot () button continually, emptying the hot water, until the entire tank of water is purged through the system.
15. The pump is now primed, and the Espresso Maker is cleaned. You are ready to pull the perfect espresso shot.

Filter Baskets: Pressurized or Non-Pressurized?

1. Your Bella Pro Espresso Maker comes with 2 sets of filter baskets. Pressurized filter holders are double wall construction and have only 1 hole on the bottom. Non-pressurized filter baskets are thinner, single wall construction with many holes on the bottom. If you are new to the third wave coffee culture, or if you are not using a dosed coffee grinder, it is best to use the pressurized baskets.
2. It is best to use pressurized filter baskets when:
 - Extracting espresso from pre-measured pods. Insert a single coffee pod into the empty 1 cup pressurized filter basket. To avoid water leakage, make sure that no part of the coffee pod filter hangs over the lip of the filter basket.
 - Extracting espresso from pre-ground coffee.
3. Tamping is not critical, but should be consistent when using pressurized filter baskets.
4. Pressurized baskets produce larger bubbles in the crema.
5. Use the non-pressurized filter baskets when:
 - Grinding fresh coffee beans.
 - Using a special dose coffee grinder.
6. The resulting brew is often less bitter.
7. **Tamping is important.** Use the tamper to apply consistent pressure. A smooth and level coffee surface is achieved by tamping evenly and firmly with a final polish or swirl.

Pull the Perfect Espresso Shot

The secret to a perfect espresso shot is all about achieving the perfect balance of acidity, sweetness, and bitterness. Many factors play a major role: temperature of the water; portafilter, and serving cups is crucial, filter baskets and steaming wand should be clean; coffee beans must be fresh and perfectly roasted. The fineness or coarseness of the grind, dose of ground coffee, and tamping pressure should be consistent when experimenting to achieve your perfect pull.

1. Place empty cappuccino shot cups onto the warming plate before the pull.
2. **Run a blank shot to preheat the cup and portafilter.**
3. Plug the Espresso Maker into a 120V AC electrical outlet. All indicator lights should be OFF.
4. Fill the water tank with up to 2.1 liters of cold, preferably filtered water, using the markings on the tank for reference. Close the lid.

IMPORTANT! Be sure to add enough water for shots plus the first blank shot.

NOTE: The water tank should always be filled past the MIN (5 oz.) mark.

Never fill the water tank past the MAX (2.1 liter) mark.

5. **Choose the appropriate filter basket.** (Please see the detailed description in the previous section: “Filter Baskets: Pressurized or Non-Pressurized?”) Insert either the 1 or 2 cup, pressurized or non-pressurized filter basket into the portafilter. (See Figure 7.)
6. Align the portafilter handle with the INSERT symbol on the brew head. (See Figure 8.)
7. Turn handle counter-clockwise (to the right) until the portafilter handle is facing front and lined up with the LOCK. Make sure the portafilter is sealed and locked securely into the brew head. (See Figure 9.)
8. Center a wide spouted container or cup onto drip plate under the 2-spout portafilter.
9. Press the POWER button to turn the Espresso Maker ON. The single shot (☞) and double shot (☞☞) buttons will begin to flash. When the system is up to temperature, all 4 buttons on the control panel will illuminate.

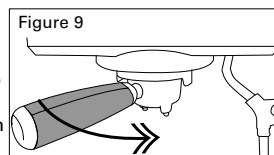
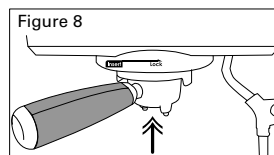
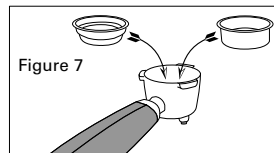

10. Press either the single (☰) or double shot (☰☰) button. The motor will sound. Both spouts will stream hot water (a blank shot) to warm the espresso cup and portafilter and then turn OFF.
11. Remove the portafilter from the brew head. Turn the handle clockwise (to the left) to UNLOCK. The portafilter will drop down from the brew head. (See Figures 10 and 11.)
12. Use the Bella Pro measuring scoop (and scale if desired) to dose ground espresso coffee and add to the filter basket. Use the 1 cup filter basket for a single espresso; the 2 cup filter for a double espresso or 2 single espressos at the same time. (See Figure 12.)
13. Use the tamper to gently press the coffee and pack it. Make sure the tamper is perfectly dry as any wet spots will result in channeling. Wipe any loose coffee grounds from the rim of the portafilter to assure a proper fit into the brew head. **NOTE:** When tamping for a double espresso, only tamp after the filter basket has been filled. Tamping between measures may create a layer in the coffee that may hinder extraction.
14. Align the portafilter handle with the INSERT symbol on the brew head and turn counter-clockwise until it is sealed and securely locked. (See Figures 8 and 9.)
15. Press either the single (☰) or double shot (☰☰) button. The motor will sound. Both spouts will stream thick, rich espresso. The Bella Pro Espresso Machine is pre-set to deliver 2 oz. (single) to 4 oz. (double) shots of espresso, before automatically turning OFF.
16. Remove the filter basket and discard used coffee puck. **CAUTION:** To avoid scalding or burns, do not attempt to remove the portafilter handle during the brewing process, or when any button on the control panel is flashing. **IMPORTANT!** Keeping your Espresso Maker clean and thoroughly rinsed is critical in pulling the perfect shot. Always run water through the brew head and purge the steam wand after each use.

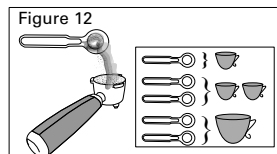
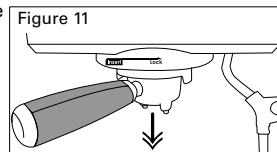
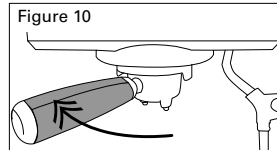



Dial In Single or Double Shot Volume

1. The Bella Pro Espresso Maker consistently dials in the perfect brew water temperature and measures the perfect volume for every shot.
2. To adjust volumes for future shots, press and hold the single or double shot programmable button for 3 seconds to adjust and to dial in future single or double shot volume. Example: to change the volume on the single shot – press and hold the single shot button for 3 seconds, water will begin to flow. Once you have the desired amount, release the single shot button to stop water flow. The new volume is now set, and can be re programmed at any time.

Texture Milk for Espresso Drinks

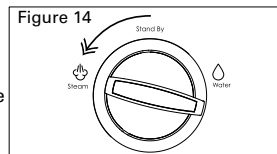
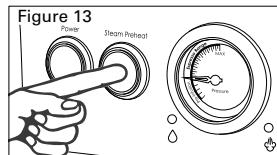
1. Transition to Steam.
IMPORTANT: Make sure the frothing pitcher is cold before texturing. Refrigerate or run cold water into the pitcher before use.
CAUTION: After extracting espresso, the steam wand is hot. Always use the silicone covers and tabs installed on both the steam wand and the water dispenser to rotate and swing either wand into the perfect position.
2. Fill the stainless steel frothing pitcher no more than one-third (1/3) full with fresh, cold milk (skim milk froths best) and place it next to the Espresso Maker.
IMPORTANT: When texturing milk, the volume will double. Do not over-fill the frothing pitcher.
3. Press the STEAM PREHEAT button. When pressed, the STEAM PREHEAT button will flash. As temperature is achieved and steam is built, the button will illuminate solid. (See Figures 13.)
4. Turn the function control dial to STEAM. Make sure the steam wand is over the drip tray. Once steam starts to come out from the wand, and not water you can change the dial back to STAND BY. (See Figures 14.)
5. Quickly place the tip of the steam wand at the surface of the milk, and turn the functional control dial back to steam. Place the frothing pitcher on an angle, and make sure the wand is around one third from either edge of the frothing pitcher.





The steam wand should barely break the milk's surface to create fine microbubbles. Try and have the steam move the milk around the inside of the frothing pitcher in a circular motion. Texture the milk until the desired volume is reached. When the milk temperature reaches between 140-150°F it is ready, or 160°F for extra hot.

6. Turn the function control dial to **STAND BY**. Drop the pitcher down to remove the steam wand.
7. **Pour.** After texturing, swirl the milk around for several seconds to incorporate the milk at the bottom, with the microfoam on top. Tap the frothing pitcher on the counter until the milk appears shiny and few bubbles remain. Pour textured milk as soon as possible. Swirl the espresso slightly to break the surface tension of the crema. Slowly introduce the microfoam, integrating it with the espresso.
8. Wipe the steam wand with a wet kitchen towel and use the silicone tab to swivel the wand back over the drip tray.
NOTE: To avoid milk build up on and inside and the outside of the steam wand, ensure to purge the steam wand after every use. Make sure the steam wand is over the drip tray and turn the function control dial to **STEAM** – leave on for a few seconds and then turn back to **STAND BY**. Clean the outside of the wand with hot water and a soft cloth.





User Maintenance Instructions

This appliance requires little maintenance. It contains no user serviceable parts. Do not try to repair it yourself. Any servicing requiring disassembly must be performed by a qualified appliance repair technician.

Care & Cleaning Instructions

CAUTION: NEVER IMMERSE THE ESPRESSO MAKER IN WATER OR ANY OTHER LIQUID.

1. When espresso making is complete, press the **POWER** button; turn the function control to **STAND BY**. Unplug the Espresso Maker from the electrical outlet and allow to cool completely before cleaning.
CAUTION: The Espresso Maker creates hot water and steam under pressure. To avoid burns on fingers or hands, always make sure the unit is unplugged and all control panel lights and buttons are **OFF** before cleaning. **NEVER** touch the portafilter immediately after brewing or steaming. Allow all parts to cool thoroughly before touching.
IMPORTANT: The portafilter and filter basket should be emptied and rinsed thoroughly with warm water after every use.

- 
- 
2. **Clean the portafilter and filter baskets.** Grasp the portafilter handle firmly and turn clockwise (to the left) until the handle faces the UNLOCKED position. The portafilter will drop down and out of the unit. (See Figures 10 and 11.)
 3. Remove the filter basket and discard used coffee puck.
 4. Rinse the portafilter and filter baskets immediately after use to remove residual coffee oils. If necessary, clean the filter basket with a kitchen brush or soak in a cleaning solution for 20 minutes. Rinse and dry thoroughly.
 5. A cleaning pin has been supplied to ease in the care and cleaning of your Espresso Maker. Use the smaller end of the cleaning pin to clear holes in the base of the filter baskets.
 6. **Clean the steam wand and water dispenser.** After frothing milk or dispensing hot water, twist to remove the water dispenser tip and the frothing tip from the steam wand and clean thoroughly.
 7. Insert the cleaning pin's larger wire into both the water dispenser's and steam wand's outlet to clear. Rinse and screw the clean water reservoir tip and frothing tip securely back into the wands.
 8. Remove the drip plate, FULL bar, and slide the drip tray straight out. Empty any collected water. Dry with a clean cloth and reassemble.
 9. Wipe the outside of the Espresso Maker and brew head with a damp cloth.
WARNING: Never use solvents or any detergents that may scratch or damage the surface of the machine.
 10. Clean the stainless steel frothing jug, tamper, by hand.
 11. **No parts of the Bella Pro Espresso Maker should be cleaned in the dishwasher.**

Descaling

Minerals and calcium found in hard-water areas can accumulate and affect the operation of your machine. Depending on water conditions and frequency of use, your Espresso Maker should be cleaned with distilled vinegar approximately every 6 months to remove scale.

1. Before cleaning your Espresso Maker, make sure the function control dial is in the STAND BY position and the appliance has been disconnected from the wall outlet.
2. Fill the water tank with 1 part white vinegar to 3 parts cold water.
3. Attach empty portafilter and any filter basket.
4. Plug the Espresso Maker into 120V AC electrical outlet.
5. Center a wide-mouth spouted container or cup under the 2-spout portafilter. Place the steam wand's tip into the frothing jug. Place an empty container under the water dispenser.
6. Plug the unit into a 120V AC electrical outlet.
7. Press the POWER button. It will begin to flash. When the system is up to temperature, all 4 buttons on the control panel will illuminate.
8. Turn the function control dial to STEAM. Allow the hot steam to purge the line for at least 45 seconds. Turn the function control dial to WATER. Allow water to fill the empty container, then discard. Turn the function control dial to STAND BY.
9. Press the double shot (☞☞) button, then empty the hot water, until the entire tank of water is purged through the system.
10. In hard water environments, it is recommended to repeat this procedure.
11. After descaling, remove the water tank and refill with fresh, cold water. Repeat steps 7 through 9 to thoroughly rinse the Espresso Maker.
WARNING! Never immerse power cord, plug or Espresso Machine in water or any other liquid. The water tank should never be completely emptied during descaling.
12. When the flow has stopped, press the POWER button. Make sure the all indicator lights are OFF. Unplug the Espresso Maker from the wall outlet when not in use.
13. Remove portafilter, containers or cups and rinse with hot water for next use.

Storing Instructions

1. Make sure unit is unplugged and fully cooled before storing.
WARNING: Never store Espresso Maker while it is hot or still plugged in.
2. Do not put any stress on cord where it enters unit, as this could cause cord to fray and break.
3. Store the Espresso Maker in its box, in a clean, dry area.

Trouble Shooting

Problem	Possible Cause	Solution
Coffee runs down the side of the portafilter.	Portafilter is not attached correctly, or has not been tightened sufficiently.	Re-insert the portafilter into the brew head. Make sure the handle is facing outward and is firmly engaged on the brew head.
	Coffee pod is not properly fitted in the filter basket.	Make sure that no part of the coffee pod filter hangs over the lip of the filter basket.
	Edge of filter insert is not free of coffee granules.	Clean around the top edge of the filter and wipe the brew head with a clean, damp cloth.
	The brew head is dirty.	Wipe brew head with a clean, damp cloth.
	Brew head rubber seal is damaged or worn.	Contact Bella Pro Customer Service.
Espresso is not streaming	No water in the water tank.	Fill tank with water.
	Water tank is incorrectly assembled.	Press firmly down on the water tank to make sure it is correctly positioned.
	Brewing filter may be blocked.	See "Descaling" section of this Instruction Manual
	The filter basket is blocked, coffee grounds are too fine or tamped down too hard.	Empty filter basket and rinse under water to clean. Use the cleaning pin to clear holes in the base of the Wipe the brew head with a cloth. Redose the filter with a coarser coffee grind and tamp with less pressure.
Espresso does not have any or enough crema.	Coffee is old or dry.	Use freshly roasted and ground coffee. Always store ground coffee in an airtight container.
	Coffee not compacted firmly enough.	Tamp coffee grounds with more pressure.
	Coffee grind is too coarse.	Use a finer grind of pre-ground coffee or grind the coffee beans to a finer texture.
	Dose is too small.	Increase dose
Coffee is too cold.	Cups, filter and filter hand are cold.	Run a blank shot to pre-heat cups, portafilter and filter baskets.
	If making a cappuccino or latte the milk may not be heated enough.	Ensure that milk is heated properly during texturing, but DO NOT boil the milk.
No steam from the steam nozzle.	Steam nozzle is blocked.	See "Care & Cleaning Instructions."

Problem	Possible Cause	Solution
Not enough froth when texturing	Milk is not fresh.	Begin again with fresh milk.
	Milk temperature is too warm.	Make sure that the milk is well refrigerated before use.
	Texturing jug is warm	Refrigerate or run cold water into the jug before use.
	Steam nozzle is blocked.	See "Care & Cleaning Instructions."
	Milk has been boiled.	Start again with fresh, chilled milk.
Cups are unevenly filled.	The milk is making large bubbles rather than microbubbles.	The tip of the steam nozzle should be positioned just below the surface of the milk.
	Uneven tamping or obstruction in the pouring spouts.	Make sure coffee is tamped evenly and check that both pouring spouts on the portafilter are unobstructed. See "Care & Cleaning Instructions."
Espresso tastes burnt.	Change the type of coffee being used.	Experiment with various types and brands of coffee beans.
	Appliance has not been rinsed after descaling.	Purge a full water tank through the Espresso Maker before pulling another espresso shot.
Pump makes an unusually loud noise.	Not enough water in the tank, or the water tank is empty.	Fill the water tank. The water tank should always be filled past the MIN (5 oz.) mark. NEVER operate the Espresso Maker with an empty water tank.
	Water tank is incorrectly assembled.	Press firmly down on the water tank to make sure it is correctly positioned.
Machine does not operate.	Portafilter may be blocked.	Remove portafilter and clean brewing head. See "Care & Cleaning Instructions."
	Machine blocked by scale buildup.	See "Descaling."

Espresso is the foundation of all café coffee. The Bella Pro 19 Bar Espresso Maker gives you the freedom to add your personal touch of milk and froth.

Bella Pro Espresso Recipes

Short Black

A single shot of espresso topped with a stable layer of crema.

Flat White

A single shot of espresso topped with a steamed milk, 1/3 coffee and 2/3 steamed milk.

Yuan Yang (Coffee with Tea)

Yuan Yang is made by making strong black tea in a pot, stirring in evaporated or sweetened condensed milk and coffee, then sweetening to taste.

- 4 small black tea bags, paper and strings removed
- 1 (14-oz) can sweetened condensed milk
- 2 cups Americano Coffee (see recipe following)

Simmer tea and 1 cup water in a 2-qt. saucepan over medium heat for 3 minutes. Squeeze out and discard tea bags. Stir in milk; boil. Cook, stirring, for 3 minutes. Stir in Americano coffee; pour into glasses.

Americano or Long Black

A standard espresso shot diluted with hot water, served in a regular coffee cup or mug. Add hot water before the espresso to maintain the delicate crema.

Café Latté

A single shot espresso with steamed milk, typically served in a glass. The top layer of microbubbles should be 10mm to seal the coffee.

Cappuccino

Espresso with steamed milk, topped with creamy froth and a dusting of chocolate. The resulting drink is approximately 2/3 milky coffee, 1/3 microbubbles.

Café Mocha

Prepared similarly to a cappuccino but with the addition of drinking chocolate. Stir chocolate into the espresso prior to adding the steamed milk and microbubbles. Top with whipped cream.

Macchiato

Traditionally served as a short or long espresso with a dash of milk or a small dollop of froth in the center of the crema.

Espresso Vodka Cocktail

- 1.5 oz. vodka
- 1/2 oz. freshly squeezed lemon juice
- 1/2 oz. simple syrup
- 2 single espresso shots
- Ice for serving
- Lemon zest for garnish

Add vodka, lemon juice, simple syrup, espresso, and ice to a drink shaker. Shake well. Pour into a chilled glass and serve over ice. Garnish with lemon zest.

Limited Two-Year Warranty

SENSIO Inc. hereby warrants that for a period of **TWO YEARS** from the date of purchase, this product will be free from mechanical defects in material and workmanship, and for 90 days in respect to non-mechanical parts. At its sole discretion, SENSIO Inc. will either repair or replace the product found to be defective, or issue a refund on the product during the warranty period.

Exclusions:

The warranty does not cover normal wear of parts or damage resulting from any of the following: negligent use of the product, use of improper voltage or current, improper routine maintenance, use contrary to the operating instructions, disassembly, repair, or alteration by anyone other than qualified SENSIO Inc. personnel. Also, the warranty does not cover Acts of God such as fire, floods, hurricanes, or tornadoes.

SENSIO Inc. shall not be liable for any incidental or consequential damages caused by the breach of any express

The warranty is only valid for the original retail purchaser from the date of initial retail purchase and is not transferable. Keep the original sales receipt, as proof of purchase is required to obtain warranty validation. Retail stores selling this product do not have the right to alter, modify, or in any way revise the terms and conditions of the warranty.

or implied warranty. Apart from the extent prohibited by applicable law, any implied warranty of merchantability or fitness for a particular purpose is limited in time to the duration of the warranty. Some states, provinces or jurisdictions do not allow the exclusion or limitation of incidental or consequential damages, or limitations on how long an implied warranty lasts, and therefore, the above exclusions or limitations may not apply to you. The warranty covers specific legal rights which may vary by state, province and/or jurisdiction.

How To Obtain Warranty Service:

You must contact Customer Service at our toll-free number: 1-866-832-4843. A Customer Service Representative will attempt to resolve warranty issues over the phone. If the Customer Service Representative is unable to resolve the problem, you will be provided with a case number and asked to return the product to SENSIO Inc. Attach a tag to the product that includes: your name, address, daytime contact telephone number, case number, and description of the problem.

Also, include a copy of the original sales receipt. Carefully package the tagged product with the sales receipt, and send it (with shipping and insurance prepaid) to SENSIO Inc.'s address. SENSIO Inc. shall bear no responsibility or liability for the returned product while in transit to SENSIO Inc.'s Customer Service Center.



For customer service questions or comments
1-866-832-4843
bellahousewares.com

Sensio Inc.
New York, NY 10016/USA

90166 RO