

PERCUSSION

D29

Cardioid Dynamic Percussion Microphone

Applications:

Rack toms
Floor toms
Guitar/bass cabinets
Electrical and
acoustic instruments



Description

The D29 is a cardioid, moving-coil dynamic microphone specifically designed for the capture and reinforcement of tom-tom drums and other acoustic percussive instruments. The cardioid polar pattern provides off-axis rejection crucial for on-stage clarity.

Although designed with percussion in mind, excellent results are also obtained when used on most electrical and acoustical instruments

The integrated drum clip is designed to facilitate rapid, optimal placement.



CAD Audio
6573 Cochran Rd., Bldg. I Solon, OH 44139 U.S.A.
Tel: (440) 349-4900 Fax: (440) 248-4904
Sales: 800-762-9266 www.cadaudio.com

D29

Cardioid Dynamic Percussion Microphone

Specifications†

Operating Principle	Moving-coil dynamic
Polar Pattern	Cardioid
Frequency Response	90Hz -13KHz
Sensitivity	-53dBV (2.2mV) @ 1 Pa
Impedance	560 ohms
Max SPL	>120dB
Dimensions	5" x 4" x 3" (12.7cm x 10.2cm x 7.6cm)
Weight	0.5lbs (0.22Kg)
RoHS	Compliant

†Specifications subject to change without notice.

Polar Pattern

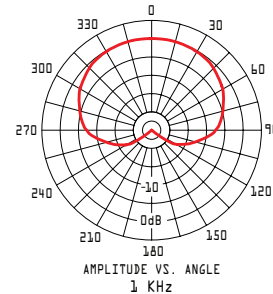

Frequency Response

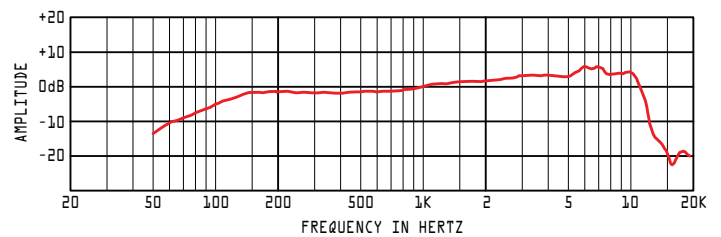

Dimensional Drawing

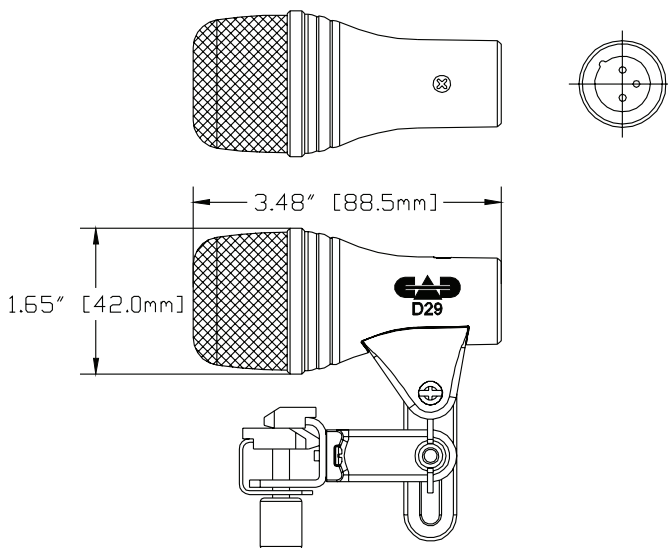

CAD Audio
6573 Cochran Rd., Bldg. I Solon, OH 44139 U.S.A.
Tel: (440) 349-4900 Fax: (440) 248-4904
Sales: 800-762-9266 www.cadaudio.com



Two-Year Limited Warranty

CAD Audio hereby warrants that this product will be free of defects in material and workmanship for a period of two years from the date of purchase. In the unlikely event that a defect occurs, CAD will, at its option, either repair or replace with a new unit of equal or greater value. In the event that a suitable replacement is unavailable, CAD Audio may elect to reimburse owner for the cost of local repairs or issue a refund in the amount of the original purchase price. Items must be purchased from an authorized CAD Audio dealer, and the warranty is not transferable from the original owner. Please retain proof of purchase to validate the purchase date and include it with any warranty claim.

This warranty excludes exterior finish or appearance, damage from abuse, misuse of the product, use contrary to CAD's instructions or unauthorized repair. All implied warranties, merchantability, or fitness for a particular purpose is hereby disclaimed and CAD hereby disclaims liability for incidental, special or consequential damages resulting from the use or unavailability of this product.

This warranty gives you specific legal rights and you may have other rights that vary from state to state. Some states do not allow the exclusion or limitation of incidental or consequential damages or limitations on how long an implied warranty lasts, so the above exclusions and limitations may not apply to you.

Note: No other warranty, written or oral is authorized by CAD Audio.

To initiate a warranty claim, please contact American Music and Sound at 1-800-431-2609 to obtain a return authorization number and shipping instructions.

- A return authorization is required for all returns. RETURNS WITHOUT A PRE-APPROVED RETURN AUTHORIZATION NUMBER WILL BE REFUSED.
- Please use at least 3 inches of padding surrounding the product for protection during shipment
- Retain your tracking number until your warranty claim has been resolved
- We recommend using an insured shipping method in case of loss or damage during shipment

If outside the United States, contact your local dealer or distributor for warranty details.