



Drum Smoker DS-SST

Assembly & Operation Instructions

Install Confidence.™



FIRE INSPIRED™

550-DS-SST

1. Important Safety Warnings

WARNING:

Please read this manual carefully before assembling and using your drum smoker. Failure to follow these instructions may result in serious injury or damage to property.

Read the Manual: Familiarize yourself with all instructions before starting assembly or operation.

Proper Ventilation: Drum Smoker is designed to operate outdoors. Always use the smoker in a well-ventilated outdoor area and away from flammable materials. Do not use it indoors, in a garage, or in enclosed spaces.

Charcoal Handling: Only use charcoal that is intended for grilling and smoking. Do not use charcoal briquettes containing lighter fluid or other additives not meant for cooking.

Use of Combustible Materials: Do not use newspaper or other combustible materials to start the charcoal. Use a chimney starter or electric starter designed for charcoal use.

Never leave the smoker unattended: Always monitor the smoker when it is in use.

Temperature Control: Be aware that the smoker can reach high temperatures quickly. Pay close attention to the temperature gauge and adjust air vents as needed to maintain your desired cooking temperature. Avoid overheating by monitoring the smoker closely during operation.

Use caution with hot surfaces: Handle all components with care and be mindful of hot surfaces.

Lid Removal Caution: When removing the lid from the smoker, be cautious of escaping hot air and steam. Open the lid slowly, away from your face, to prevent burns.

Food Safety: Ensure that food is cooked to the recommended safe temperatures. Use a food thermometer to verify that meat, poultry, and seafood are cooked thoroughly to prevent foodborne illnesses.

Grease and Drippings: Grease and drippings from food can cause flare-ups and fires. Keep a close eye on the smoker during cooking, and have a drip pan ready to catch any excess grease.

Properly dispose of ashes: Allow ashes to cool completely before disposing of them in a non-flammable container.

WARNING:

Please adhere to these warnings and safety precautions to ensure safe operation of your outdoor charcoal drum smoker. Failure to do so may result in severe injury or property damage.

Cleaning and Maintenance: Wait for the smoker to cool down before attempting to clean it. Inspect all components for wear and tear regularly. Replace damaged or worn parts immediately.

2. Parts and Tools Required

Parts:

Drum Assembly

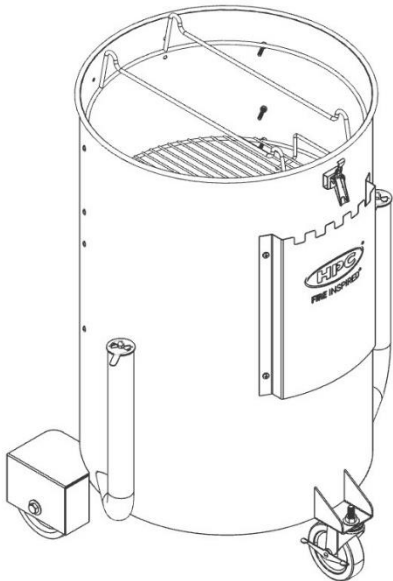

Lid Assembly

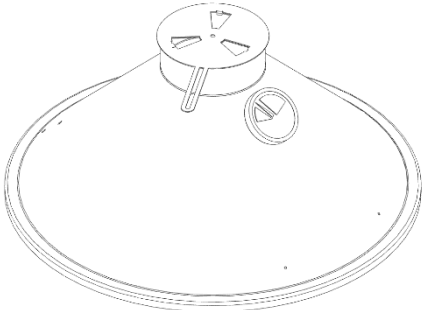

Handle

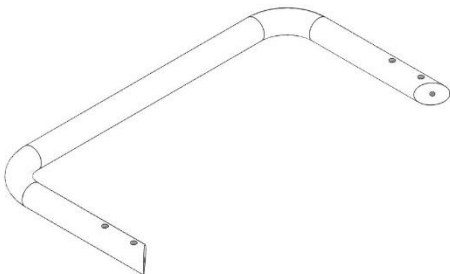

Lid Handle

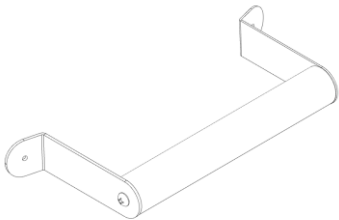

Lid Hinge Bracket

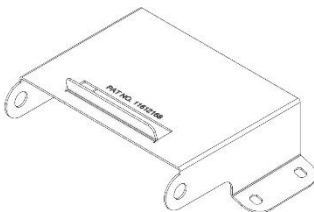

Tools Supplied:

No. 2 Phillips Screwdriver

Wrench

3. Assembly Instructions

Step 1: Unboxing

- Please exercise caution when unboxing the product. Begin by delicately detaching the straps securing the box, and subsequently lift the box utilizing the handle cutouts for removal.
- The smoker components have been thoughtfully organized for your convenience, facilitating the identification of unassembled parts, which include the Lid, Lid Handle, Lid Hinge, and Drum Handle.
- Within the smoker, various components are securely fastened using zip ties. To prevent any disruption during the assembly process, it is imperative to cut all zip ties and remove the individual parts from the smoker.
- Please disengage the drum smoker from the lower compartment and ensure that the locking mechanism on the front wheel is engaged to prevent any unintended movement.

Step 2: Lid Assembly

- Place the lid on the surface and proceed to identify the handle, which should have been included in your equipment package.
- Utilize the provided hardware and accompanying tools to securely affix the handle to the lid.

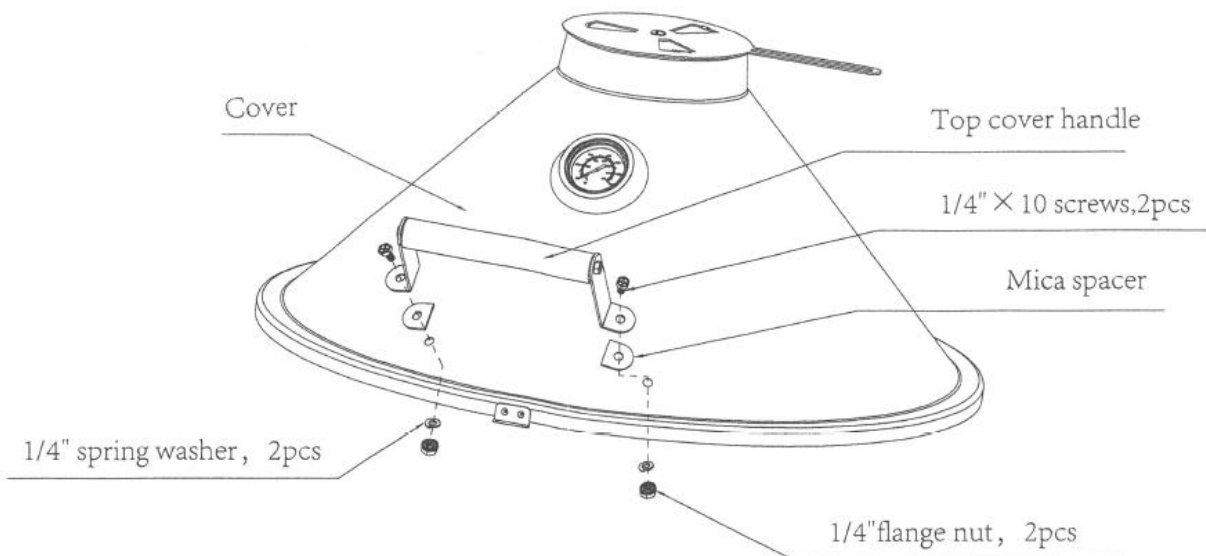

3. Assembly Instructions

Step 3: Handle

- For your convenience, we have pre-attached the Handle Mounting brackets to the drum.
- Insert the handle into the bracket as indicated.
- Utilize the provided hardware and accompanying tools to securely attach the handle to the drum.

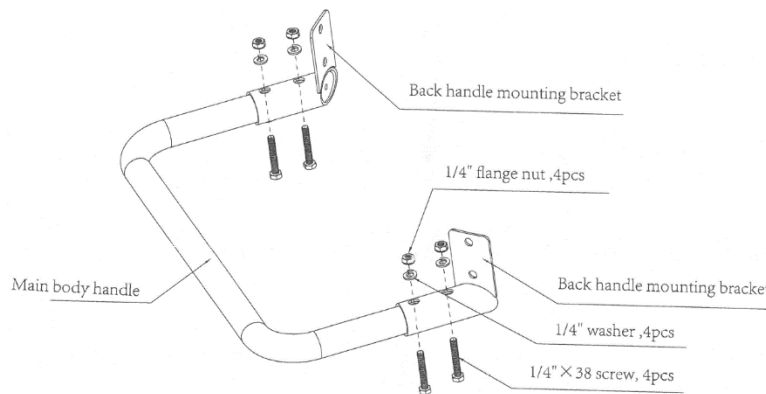

Step 4: Hinge and Lid

- Please locate the lid hinge bracket and proceed to detach the quick disconnect. Insert the bracket into the drum hinge bracket, ensuring that the tab on the lid hinge bracket is positioned on the inside. Next, insert the quick disconnect rod and secure it by attaching the clip.
- Please position the lid as shown and proceed to insert the associated hardware before firmly fastening the lid in place.

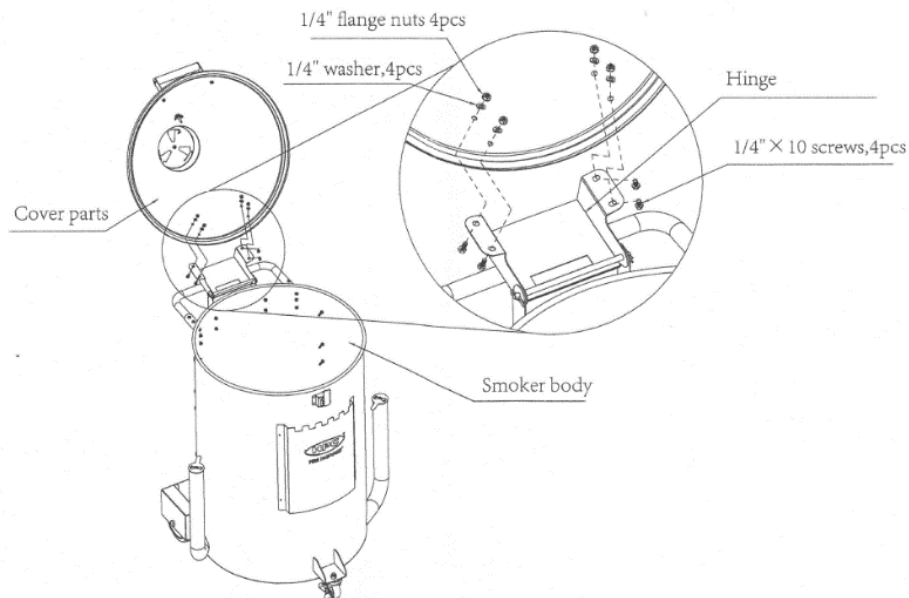

3. Assembly Instructions

Step 5: Final Check

The assembly of the drum smoker has been successfully completed. To ensure a safe operational environment, it is imperative that you verify the secure placement of all components prior to proceeding further. Place the remaining part inside the smoker.

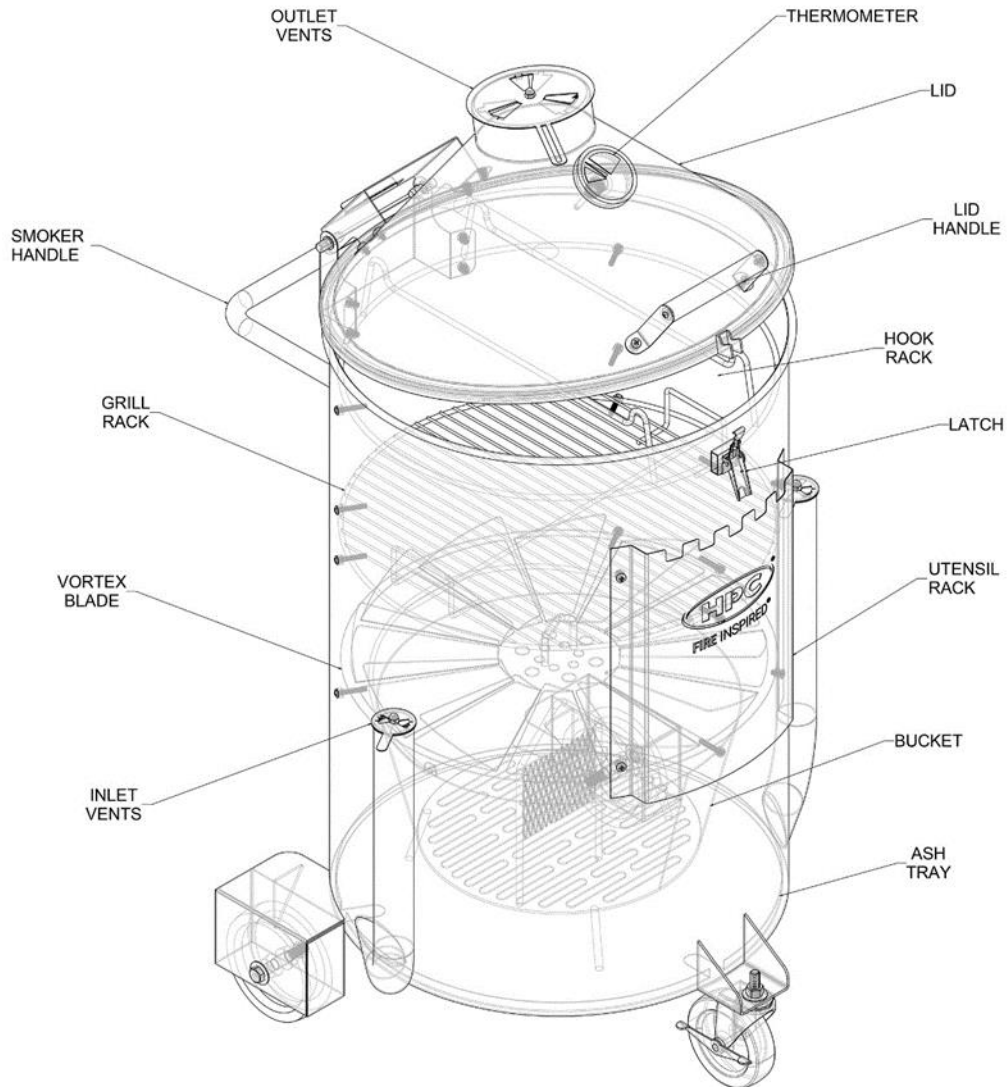

4. Operating Instructions

WARNING:

Before use, verify the following:

Assembly: Ensure that your drum smoker is properly assembled as per the instructions. Check that all parts are securely attached.

Location: Place your drum smoker on a level and stable surface, away from flammable materials, and at a safe distance from any structures or objects. Use your smoker outdoors only.

Charcoal: Use high-quality charcoal briquettes or lump charcoal. Fill the charcoal bucket inside the drum to the desired level based on your cooking needs. Place a few wood chunks or wood chips on top of the charcoal for added flavor.

1. Begin the process by unlatching the lid using the provided latch. Ensure that the lid is opened with caution to prevent accidents.
2. Carefully extract the Hook Rack, Grill Rack, and Vortex Blade from the Drum.
3. Place charcoal briquettes or lump charcoal into the designated Bucket. Ensure it is placed safely within the container.
4. Introduce the fire starter and ignite it securely. Handle the fire starter carefully and responsibly, following all safety guidelines.
5. It is strongly advised to close the lid and fully open both the inlet and outlet vents to initiate the ignition process.

WARNING:

Extreme heat may be generated during this phase and maintain a safe distance.

6. After the charcoal has been ignited, adjust the inlet and outlet vents to achieve the desired cooking temperature. (Refer to the attached Meat Smoking Guide for guidance.)

WARNING:

Be cautious when adjusting to avoid burns from hot surfaces.

7. Once the desired temperature has been reached, carefully reposition the vortex blade, grill rack, or hook rack.
8. Place the food onto the cooking surface and subsequently lower the lid. Be cautious when positioning food to prevent burns or spills.
9. To optimize smoking results, refrain from frequently opening the lid. Consistent lid openings may result in temperature fluctuations and impact cooking outcomes.

5. Cleaning and Maintenance Instructions

Before Each Use:

Inspect the Smoker: Before every smoking session, inspect your smoker for any visible damage or issues. Make sure all the components, such as the grates, vents, and thermometer, are in good condition.

Clean Cooking Grates: Before each use, scrape the cooking grates with a grill brush or scraper to remove any leftover residue from previous smoking sessions. This will prevent old food bits from affecting the flavor of your new smoke.

Check Fuel Supply: Ensure you have enough charcoal and wood chunks or chips for your smoking session. Prepare these in advance to minimize interruptions during the smoking process.

After Each Use:

Let It Cool: Allow the smoker to cool down completely before starting any cleaning or maintenance tasks. This ensures your safety and prevents accidental burns.

Clean the Grates: Once the smoker is cool, clean the cooking grates thoroughly with a grill brush to remove any remaining residue. You can also use a damp cloth for a more thorough clean.

Clean the Interior: Remove any loose ash or debris from the interior of the smoker using a brush or vacuum cleaner. Make sure the vents and air inlets are clear for proper airflow.

Inspect the Seals: Check the smoker's seals and gaskets for any signs of wear or damage. Replace them if needed to maintain proper temperature control.

Empty Ashes: Carefully remove the ashes from the charcoal pan or ashtray. Dispose of them properly. This will prevent airflow issues and make it easier to start your next fire.

Storage: Close the lid, latch it, shut off all the vents, and avoid exposing it to wet weather.

Regular Maintenance:

Deep Cleaning: Perform a more in-depth cleaning. Remove the cooking grates and any other removable parts. Scrub them clean with warm soapy water and a brush or sponge.

Replenish Supplies: Stock up on charcoal, wood chips, and other smoking supplies, so you're always ready for your next smoke.

By following this cleaning and maintenance routine, you can keep your smoker in good working condition with minimal effort and enjoy consistent and flavorful smoked meats.



MEAT SMOKING GUIDE

Beef smoking times and temperatures			
<i>Meat Type</i>	<i>Smoker Temp</i>	<i>Finished Temp</i>	<i>Smoking Time</i>
Beef brisket	225 – 250°F	190 – 205°F	12 – 20 hours
Back ribs	225 – 250°F	185 – 190°F	3 – 4 hours
Short ribs	225 – 250°F	190 – 200°F	6 – 8 hours
Spareribs	225 – 250°F	190 – 203°F	5 – 6 hours
Prime rib	225 – 250°F	135°F for Medium	15 minutes/lb
Chuck roast	225 – 250°F	190 – 200°F	12 – 20 hours
Rump roast	225 – 250°F	145°F for Well Done	30 minutes/lb
Whole ribeye	225 – 250°F	135°F for Medium	25 minutes/lb
Tenderloin	225 – 250°F	130 – 140°F	2 ½ – 3 hours
Tri-tip	225 – 250°F	130 – 140°F	2 – 3 hours
Sausage	225 – 250°F	160°F	30 – 60 mins

Poultry smoking times and temperatures			
<i>Meat Type</i>	<i>Smoker Temp</i>	<i>Finished Temp</i>	<i>Smoking Time</i>
Chicken whole	275 – 350°F	170°F	2 – 3 hours
Chicken quarters	275 – 350°F	170°F	1 – 2 hours
Chicken thighs	275 – 350°F	170°F	1 ½ hours
Chicken wings	275 – 350°F	170°F	1 ¼ hours
Turkey whole	275 – 350°F	170°F	4 – 5 hours
Turkey leg	275 – 350°F	170°F	2 – 3 hours
Turkey wings	275 – 350°F	170°F	2 – 2 ½ hours
Turkey breast	275 – 350°F	165°F	4 hours
Quail / Pheasant	225°F	165°F	1 hour
Cornish Hens	240°F	165°F	2 hours
Whole duck	225 – 250°F	165°F	4 hours

Pork smoking times and temperatures			
<i>Meat Type</i>	<i>Smoker Temp</i>	<i>Finished Temp</i>	<i>Smoking Time</i>
Pork butt	225 – 250°F	205°F	1.5 hours/lb
Baby back ribs	225 – 250°F	180°F	5 hours
Spareribs	225 – 250°F	180 – 185°F	5 – 7 hours
Loin	225 – 250°F	145°F	4 – 5 hours
Belly bacon	less than 100°F	140°F	6 hours
Whole hog	225 – 250°F	205°F	16 – 18 hours
Tenderloin	225 – 250°F	160°F	2 ½ – 3 hours
Pork sausage	225 – 250°F	165°F	1 – 3 hours

Fish and seafood smoking times and temperatures			
<i>Meat Type</i>	<i>Smoker Temp</i>	<i>Finished Temp</i>	<i>Smoking Time</i>
Salmon whole	200°F	145°F	Starts to flake
Whole trout	225°F	145°F	1 hour
Salmon filet	220°F	145°F	1 hour
Tilapia filet	220°F	145°F	1 hour
Lobster tails	225°F	140°F	45 min
Oysters	225°F	N/A	30 – 40 min
Scallops	225°F	145°F	45 – 60 min
Shrimp	225°F	N/A	20 – 30 min

Lamb smoking times and temperatures			
<i>Meat Type</i>	<i>Smoker Temp</i>	<i>Finished Temp</i>	<i>Smoking Time</i>
Lamb leg	225 – 250°F	140 – 150°F	4 – 8 hours
Lamb shank	225 – 250°F	190°F	4 – 5 hours
Lamb shoulder	225 – 250°F	170°F	5 – 5 ½ hours
Lamb rack	200 – 225°F	135 – 140°F	1 ¼ hours