



**DUAL BREW  
SINGLE SERVE COFFEE MAKER**  
Instruction Manual



Thank You for your purchase

Register & sign up for special  
announcements and trendy recipes!

Tell us what you think!  
Rate, review or ask us a question.

@bellahousewares.com  
#getinspired



**BellaLife**



**BellaLifestyle**



## TABLE OF CONTENTS

Important Safeguards .....	2-4
Additional Important Safeguards .....	4-6
Notes on the Plug .....	5
Notes on the Cord .....	6
Plasticizer Warning .....	6
Electric Power .....	6
Getting To Know Your Coffee Maker .....	7
Control Panel .....	8
Before Using For The First Time .....	8-9
The Capsule Adaptor .....	9-10
Using The Ground Coffee Adaptor .....	11-12
Brewing Another Cup .....	12
User Maintenance Instructions .....	12-13
Descaling Instructions .....	13
Storing Instructions .....	14
Warranty .....	15-16

# IMPORTANT SAFEGUARDS

**WARNING: When using electrical appliances, basic safety precautions should always be followed, including the following:**

1. Read all instructions.
2. This appliance is not intended for use by persons (including children) with reduced physical, sensory, or mental capabilities, or lack of experience and knowledge, unless they are closely supervised and instructed concerning use of the appliance by a person responsible for their safety.
3. Close supervision is necessary when any appliance is used by or near children. Children should be supervised to ensure that they do not play with the appliance.
4. Do not touch hot surfaces. Use handles or knobs. Care must be taken, as burns can occur from touching hot parts or from spilled, hot liquid.
5. To protect against electric shock, do not place cord, plug, or coffee maker in water or other liquid.
6. Unplug from outlet when the coffee maker is not in use and before cleaning. Allow to cool before putting on or taking off parts and before cleaning the appliance.
7. Coffee maker must be operated on a flat surface away from the edge of counter to prevent accidental tipping.
8. Do not operate any appliance with a damaged supply cord or plug, or after the appliance malfunctions or has been dropped or damaged in any manner. Supply cord replacement and repairs must be conducted by the manufacturer, its service agent, or similarly qualified persons in order to avoid a hazard. Call the provided customer service number for information on examination, repair, or adjustment.

- 
- 
- 
9. The use of accessory attachments not recommended by the appliance manufacturer may cause injuries.
  10. Do not use outdoors.
  11. Do not let cord hang over edge of table or counter or touch hot surfaces, including stove.
  12. Do not place on or near a hot gas or electric burner, or in a heated oven.
  13. Avoid contacting moving parts.
  14. Be certain lid is securely in place during frothing or warming.
  15. To disconnect appliance, press control button(s) until power indicator light is no longer glowing and then remove plug from wall outlet.
  16. To unplug, grasp the plug and pull from the outlet. Never pull from the power cord.
  17. Do not place coffee maker in a cabinet when in use.
  18. **WARNING!** To avoid hot water spraying from the piercing needle, do not lift the lid during the brew process.
  19. Do not use appliance for other than intended use.
  20. **WARNING!** To reduce the risk of fire or electric shock, do not remove the bottom cover of the coffee maker. There are no user-serviceable parts inside. Repair should be done by authorized service personnel only.
  21. **CAUTION!** Cut Hazard: Removable single-serve capsule holder contains a sharp needle. Use caution when handling.
  22. **CAUTION!** Cut Hazard: Piercing needle is sharp. Use caution when cleaning.

- 
23. To reduce the risk of fire, do not store anything directly on top of the appliance surface when the appliance is in operation. **CAUTION:** There are two sharp needles that puncture the capsules. One is located inside the capsule adaptor and the other is located on the top underside of the adaptor compartment. To avoid risk of injury do not place fingers inside either part. Also exercise caution when cleaning the parts. **CAUTION:** There are boiling water in the front tab lid section during the brew process. Do not open the lid at any time for risk of injury.
  24. Only use capsules intended for this appliance. If the capsule does not fit, do not force the capsule into the appliance.
  25. **WARNING:** To avoid the risk of injury, do not open the brew chamber during the brew process.





# SAVE THESE INSTRUCTIONS FOR HOUSEHOLD USE ONLY

## ADDITIONAL IMPORTANT SAFEGUARDS



**THIS APPLIANCE GENERATES HEAT AND ESCAPING STEAM DURING USE. PROPER PRECAUTIONS MUST BE TAKEN TO PREVENT THE RISK OF BURNS, FIRES, OR OTHER INJURY TO PERSONS OR DAMAGE TO PROPERTY.**

1. All users of this appliance must read and understand this Instruction Manual before operating or cleaning this appliance.

- 
- 
2. The cord to this appliance should be plugged into a 120V AC electrical outlet only.
  3. Use water only in this appliance. Do not put any other liquids or food products in this appliance. Do not mix or add anything to the water placed in this appliance, except as instructed in the User Maintenance Instructions to clean the appliance.
  4. DO NOT attempt to move an appliance containing hot liquids. Allow appliance to cool completely before moving.
  5. Keep appliance at least 4 inches away from walls or other objects during operation. Do not place any objects on top of appliance while it is operating. Place the appliance on a surface that is resistant to heat.
  6. If this appliance begins to malfunction during use, immediately remove plug from wall outlet. Do not use or attempt to repair the malfunctioning appliance.
  7. Do not use this appliance after it has fallen into or has become immersed in water. Doing so could result in personal injury or property damage.
  8. It is recommended to let this appliance cool down before adding water or it could result in personal injury due to steam exposure.
  9. Always use fresh, cool water in your appliance. Warm water or other liquids, except as listed in cleaning section, may cause damage to the appliance.

### **NOTES ON THE PLUG**

This appliance has a polarized plug (one blade is wider than the other). To reduce the risk of electric shock, this plug will fit in a polarized outlet only one way. If the plug does not fit fully into the outlet, reverse the plug. If it still does not fit, contact a qualified electrician. Do not modify the plug in any way.

## NOTES ON THE CORD

- a) A short power-supply cord (or detachable power-supply cord) is provided to reduce risks resulting from becoming entangled in or tripping over a longer cord.
- b) Longer detachable power-supply cords or extension cords are available and may be used if care is exercised in their use.
- c) If a long detachable power-supply cord or extension cord is used:
  - 1) The marked electrical rating of the detachable power-supply cord or extension cord should be at least as great as the electrical rating of the appliance;
  - 2) If the appliance is of the grounded type, the extension cord should be a grounding- type 3-wire cord; and
  - 3) The longer cord should be arranged so that it will not drape over the countertop or tabletop where it can be pulled on by children or tripped over.

## PLASTICIZER WARNING

**CAUTION:** To prevent Plasticizers from migrating from the finish of the counter top or table top or other furniture, place **NON-PLASTIC** coasters or place mats between the appliance and the finish of the counter top or table top. Failure to do so may cause the finish to darken; permanent blemishes may occur, or stains can appear..

## ELECTRIC POWER

If the electrical circuit is overloaded with other appliances, your appliance may not operate properly. It should be operated on a separate electrical circuit from other appliances.

**WARNING: TO REDUCE THE RISK OF FIRE OR ELECTRICAL SHOCK, DO NOT REMOVE THIS COVER.NO USER SERVICEABLE PARTS INSIDE. REPAIR SHOULD BE DONE BY AUTHORIZED SERVICE PERSONNEL ONLY.**



## Getting To Know Your Coffee Maker

Product may vary slightly from illustration.

1. Front lid tab
2. Adaptor compartment lid
3. Adaptor compartment
4. Water outlet pin
5. Control panel
6. Main housing
7. Bottom cover
8. Water tank cover
9. Water tank
10. Drip tray cover
11. Drip tray
12. Ground coffee adapter
13. Capsule Adapter
14. Cleaning Pin (Stored in drip tray)

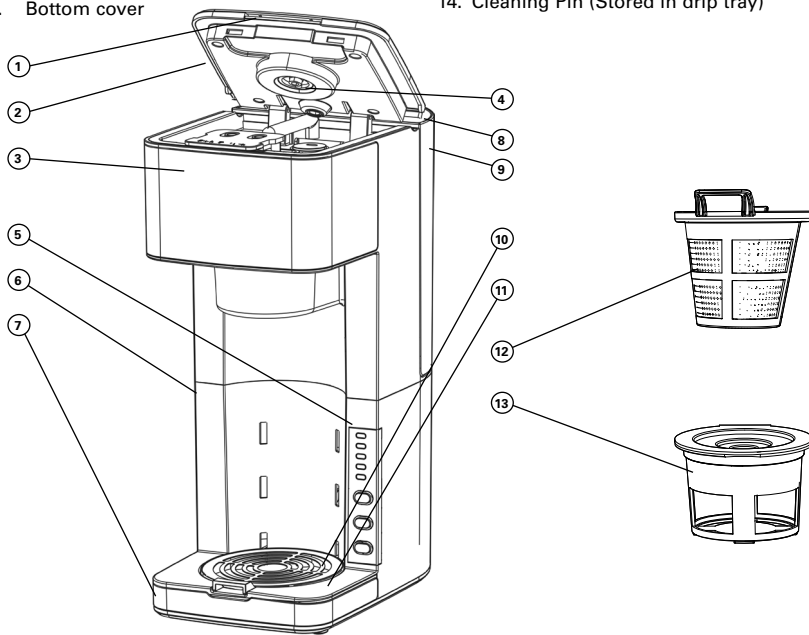

## Control Panel

1. Size Indicator Light (White)
2. Ground Coffee Button (White)
3. Size Button (White)
4. Capsule Button (White)
5. Clean Indicator Light (White) ?

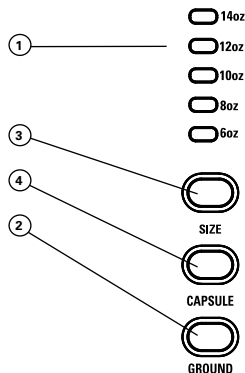

## Before Using For The First Time

**CAUTION:** To protect against electrical shock, do not immerse the Coffee Maker or allow the power cord to come into contact with water or other liquids. Remove all packing material and labels from the inside and outside of the Coffee Maker. Place the unit on a flat, clean surface. Make sure to remove both adaptors from the inner packaging.

1. Before use, thoroughly clean both adaptors with warm soapy water.
2. Clean the inside of the unit, it is recommended to brew a full tank of water, which corresponds to brew 3 to 4 tall cups.
3. Grasp the removal water tank using the designated grips. Lift the water tank up and remove it from the base of the unit.
4. Remove the lid and fill the water tank to the MAX indicator line with cold water.

**NOTE:** Never fill the water tank past the MAX indicator line and ensure water level is above the MIN indicator line.

5. Put the lid back and put the water tank back into place. Place down firmly to make sure it is securely in place.

6. Select the desired height for the drip tray, depending on the size of the cup, mug, or tumbler being used.
7. Place the empty cup, mug, or tumbler in position on the drip tray cover.

**NOTE:** Do not add any adaptor for this initial cleaning.

8. To select the brew size (6 oz, 8 oz, 10 oz, 12 oz, or 14 oz.), press the Size button until the indicator light illuminates the desired size.
9. Press either the Ground Coffee or Capsules button.
10. At the end of the cycle, the Coffee Maker enters standby mode.

**IMPORTANT:** Repeat this process twice to thoroughly clean the machine before using for the first time.

11. Unplug the Coffee Maker when not in use.



## The Capsule Adaptor

**WARNING:** Before brewing, it is recommended the water tank be filled at least to the MIN indicator line. To avoid damage to your Coffee Maker, never operate your Single Serve Coffee Maker when the water tank is empty.

1. Grasp the removal water tank using the designated grips. Lift the water tank up and remove it from the base of the unit.
2. Remove the lid and fill the water tank to the MAX indicator line with cold water.

**NOTE:** Never fill the water tank past the MAX indicator line and ensure water level is above the MIN indicator line. **IMPORTANT:** For optimal flavor, distilled water is preferred.

3. Put the lid back and put the water tank back into place.
4. Place down firmly to make sure it is securely in place.
5. Select the desired height for the drip tray, depending on the size of the cup, mug, or tumbler being used.
6. Place the empty cup, mug, or tumbler in position on the drip tray cover.
7. Pull the adaptor compartment lid's front lid tab up to unlock and lift the lid.

- 
- 
- 
8. Choose the capsule adaptor. Add the capsule of your choice into the adaptor. Press down on the capsule until it is flush with the adaptor. You will hear a pierce as the needle penetrates the capsule.
  9. Place the capsule adaptor into the adaptor compartment.
  10. Press the adaptor compartment lid down firmly. An audible click can be heard as the lid is locked firmly into position, and the top of the capsule will be punctured.
  11. Plug the Coffee Maker into a 120V AC electrical wall outlet.
  12. To select the brew size (6 oz, 8 oz, 10 oz, 12 oz, or 14 oz), press the Size button until the white indicator light illuminates the desired size.
  13. Press the Capsule button to begin the brew cycle.
  14. The Coffee Maker begins heating the water.
  15. The pump will then activate, and coffee will begin to stream through the nozzle.
  16. To interrupt the brewing cycle at any time, press the Capsule button. Then remove the plug from the wall outlet.
  17. At the end of the cycle, the Coffee Maker enter standby mode.
  18. Allow unit to cool before removing the used capsule to discard.
  19. Unplug the Coffee Maker when not in use.

**CAUTION:** There are two sharp needles that puncture the capsules. One is located inside the capsule adapter and the other is located on the top underside of the adapter compartment. To avoid risk of injury, do not place fingers inside either part. Also exercise caution when cleaning the parts.

## Using The Ground Coffee Adaptor

The ground coffee adaptor allows you to create your own favorite blend of coffee. Personalize your blends by adding a dash of cinnamon, orange peel, cardamom, or vanilla bean for flavoring, to name a few options.

**NOTE:** For best results, use medium ground coffee.

**WARNING:** Before brewing, it is recommended the water tank be filled at least to the MIN indicator line. To avoid damage to your Coffee Maker, never operate your Single Serve Coffee Maker when the water tank is empty.

1. Grasp the removal water tank using the designated grips. Lift the water tank up and remove it from the base of the unit. (See Figure 1)
2. Remove the lid and fill the water tank to the MAX indicator line with cold water.

**NOTE:** Never fill the water tank past the MAX indicator line and ensure water level is above the MIN indicator line.

**IMPORTANT:** For optimal flavor, distilled water is preferred.

3. Put the lid back and put the water tank back into place. Place down firmly to make sure it is securely in place.
4. Select the desired height for the drip tray, depending on the size of the cup, mug, or tumbler being used.
5. Place the empty cup, mug, or tumbler in position on the drip tray cover.
6. Pull the adaptor compartment lid's front lid tab up to unlock and lift the lid.
7. Choose the ground coffee adaptor and fill it in with drip or regular ground coffee.
8. Press the adaptor compartment's lid down firmly. An audible click can be heard as the lid is locked firmly into position.
9. Plug the Coffee Maker into a 120V AC electrical wall outlet.
10. To select the brew size (6 oz, 8 oz, 10 oz, 12oz, or 14 oz), press the Size button until the white indicator light illuminates the desired size.
11. Press the Ground Coffee button to begin the brew cycle. The white BREW light will illuminate.
12. The Coffee Maker begins heating the water.

- 
13. When the water has reached the optimum temperature, the pump will then activate and coffee will begin to stream through the nozzle.
  14. To interrupt the brewing cycle at any time, press the Ground Coffee button. Then remove the plug from the wall outlet.
  15. At the end of the cycle, the Coffee Maker enter standby mode.
  16. Allow unit to cool before removing the used capsule to discard.
  17. Unplug the Coffee Maker when not in use.

## Brewing Another Cup

You can brew cup after cup of your favorite hot beverage

## User Maintenance Instructions



This appliance requires little maintenance. It contains no user-serviceable parts. Any servicing requiring disassembly other than cleaning must be performed by a qualified appliance repair technician.

1. Always make sure Coffee Maker is unplugged and the drip tray and cover are cool before removing from the base.
  2. Rinse drip tray and cover and replace in the Coffee Maker base.
  3. Press the adaptor compartment's front lid to unlock and lift the lid.
  4. Remove the used capsule from the capsule adaptor and discard. Rinse the capsule adaptor in warm water before each use.
  5. When using the reusable ground coffee adaptor, discard the used coffee. Wash adaptor in warm, soapy water, to remove all coffee grinds. Rinse well.
- 

**NOTE:** Both the capsule and the ground coffee adaptors are top rack dishwasher safe.



6. Use a damp paper towel or sponge to completely remove any residue from the adaptor compartment.

- 
7. Wipe the exterior of the Coffee Maker with a damp cloth to remove superficial stains. For stubborn stains, use a nylon or plastic pad with a non-abrasive cleanser. Do not use metal scouring pads or abrasive cleansers.
  8. During use, if you notice the coffee maker isn't working properly, check whether the water outlet hole and/or the capsule adapter have a blockage. Use the cleaning pin to clean out the corresponding blocked hole(s).
  9. When cleaning, also check whether the hole on the water outlet pin and capsule adapter are clear. If there is a blockage, use the cleaning pin to pass through the corresponding blocked hole(s).

## Descaling Instructions

Special cleaning of your Coffee Maker is recommended at least twice a year, depending on frequency of use and quality of water used in the unit. If water in your area is especially hard, the following cleaning procedure should be performed more often since minerals in water can detract from the flavor of the coffee and possibly lengthen brew time.

**NOTE:** If the CLEAN red light on the control panel flashes, it means must be cleaned

- 
1. Fill water tank with 1-part white vinegar to 3-parts cold water Do not add any adaptor.
  2. Place an empty tumbler in position on the drip tray cover.
  3. Press and hold the Size button and Capsule button at the same time to start the product and start cleaning.
  4. The CLEAN red indicator is always on, and the Capsule button white indicator is always on.
  5. The heater will start to heat up. After heating, it will be pre-soaked for a period of time, and then the hot water will be pumped out to complete a cleaning procedure.
  6. Repeat steps 3 to 6 until the water tank is empty.
  7. Following the same procedure, continue to run clean water through the Coffee Maker three times.
  8. Unplug the Coffee Maker when not in use.
  9. Dry parts thoroughly. Wipe the Coffee Maker's exterior with a dry cloth.
- 

## Storing Instructions

1. Unplug unit and allow to cool.
2. Never wrap cord tightly around the appliance. Do not put any stress on the cord where it enters the unit, as it could cause the cord to fray and break.
3. Store one clean adaptor in the Coffee Maker's adaptor compartment.
4. Store the other adapter with the unit.
5. Store the Coffee Maker in a cool, dry place.
6. Never store unit while it is still plugged in.



## Limited Two-Year Warranty

SENSIO Inc. hereby warrants that for a period of **TWO YEARS** from the date of purchase, this product will be free from mechanical defects in material and workmanship, and for 90 days in respect to non-mechanical parts. At its sole discretion, SENSIO Inc. will either repair or replace the product found to be defective, or issue a refund on the product during the warranty period.

### Exclusions:

The warranty does not cover normal wear of parts or damage resulting from any of the following: negligent use of the product, use of improper voltage or current, improper routine maintenance, use contrary to the operating instructions, disassembly, repair, or alteration by anyone other than qualified SENSIO Inc. personnel. Also, the warranty does not cover Acts of God such as fire, floods, hurricanes, or tornadoes.

SENSIO Inc. shall not be liable for any incidental or consequential damages caused by the breach of any express or implied warranty. Apart from the extent prohibited by applicable law, any implied warranty of merchantability or

The warranty is only valid for the original retail purchaser from the date of initial retail purchase and is not transferable. Keep the original sales receipt, as proof of purchase is required to obtain warranty validation. Retail stores selling this product do not have the right to alter, modify, or in any way revise the terms and conditions of the warranty.

fitness for a particular purpose is limited in time to the duration of the warranty. Some states, provinces or jurisdictions do not allow the exclusion or limitation of incidental or consequential damages, or limitations on how long an implied warranty lasts, and therefore, the above exclusions or limitations may not apply to you. The warranty covers specific legal rights which may vary by state, province and/or jurisdiction.

### **How To Obtain Warranty Service:**

You must contact Customer Service at our toll-free number: 1-866-832-4843. A Customer Service Representative will attempt to resolve warranty issues over the phone. If the Customer Service Representative is unable to resolve the problem, you will be provided with a case number and asked to return the product to SENSIO Inc. Attach a tag to the product that includes: your name, address, daytime contact telephone number, case number, and description of the problem.

Also, include a copy of the original sales receipt. Carefully package the tagged product with the sales receipt, and send it (with shipping and insurance prepaid) to SENSIO Inc.'s address. SENSIO Inc. shall bear no responsibility or liability for the returned product while in transit to SENSIO Inc.'s Customer Service Center.





**For customer service questions or comments**  
**1-866-832-4843**  
**[bellahousewares.com](https://bellahousewares.com)**

Sensio Inc.  
New York, NY 10016/USA

90192 R1