

Capsule size :

Serial :



MADE IN BELGIUM

FETON INTERNATIONAL SRL

DATASHEET

COMPACT 60

Rue de la Croix du Maieur, 8 - 7110 Strépy-Bracquegnies - Belgium
Tel : +32-2-420 52 00 / contact@feton.com
TVA BE 0674 542 750 / ING BE07-3630665252-66 / BIC : BBRUBEBB



FETON International SRL

 **Rue de la Croix du Maieur, 8
7110 Strépy-Bracquegnies.
Belgium**

 **Tel : +32-2-420 52 00**

 **contact@feton.com**

TVA BE 0674 542 750
ING BE07-3630665252-66
BIC : BBRUBEBB

CONTENTS

1	PRODUCT PRESENTATION	5
2	SAFETY INFORMATION AND DISCLAIMER	5
3	TECHNICAL DATA	6
4	HOW TO USE	8
5	HOW TO CLEAN	10

1 PRODUCT PRESENTATION

- Each machine does one single capsule size.
- No adjustment necessary.
- PMMA plates.
- Stainless steel frame and small parts.
- Exist for all sizes of capsules 000 00 1 2 3 and 4.
- 60 Capsules capacity.
- Easy to clean.



2 SAFETY INFORMATION AND DISCLAIMER

All material should be cleaned before every use. (refer to section 5)

Many parts are heavy and might cause injury if mishandled or in case of fall.

Always work on a stable and flat surface, at a height that is comfortable to work while standing. Have sufficient free space around the machine you are working with.

As the filling is manual, results may vary depending on the user. Other factors can influence the results such as but not limited to: type of powder, number of tamps, filling weight, capsule size, vibration type and intensity. It is the responsibility of the user to make sure the prescribed dose is respected. Feton International is not responsible for wrong dosing.

Illustrations, descriptions and specifications are not contractual and are subject to change without prior notice.

Feton International srl declines all liability in the event of improper use of its products.

3 TECHNICAL DATA

3.1 COMPONENTS LIST AND MATERIALS

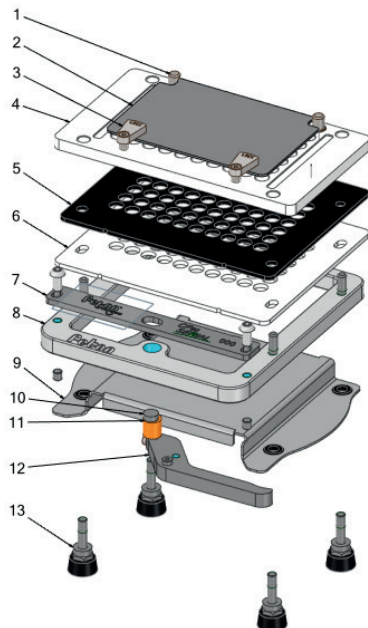

Item N°	Quantity	Name	Material
1	2	Hinge	304 Stainless Steel
2	1	Lid	316 Stainless Steel
3	2	Lock	316 Stainless Steel
4	1	Top Plate	PMMA
5	1	Filling Plate	PMMA
6	1	Bottom Plate	PMMA
7	1	Plate Pusher	316 Stainless Steel
8	1	Frame	304 Stainless Steel
9	1	Base Plate	316 Stainless Steel
10	1	Eccentric Pin	304 Stainless Steel
11	1	Bushing	Bronze
12	1	Lever	304 Stainless Steel
13	4	Foot	Rubber

3.2 DIMENSIONS AND WEIGHT

Number of Capsules	Capsules Sizes options	Weight
60	000-00-0-1-2-3-4	1,7 kg

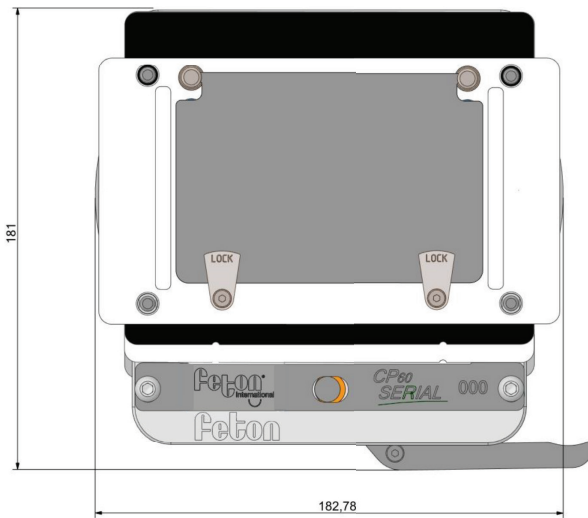
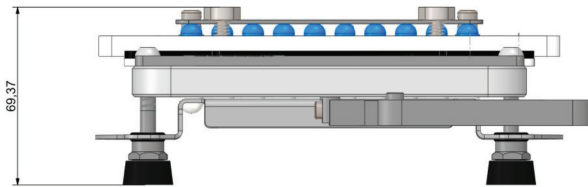

4 HOW TO USE

NOTE : Operate your capsule filler at least one time without filling the capsules (steps 3-4-5-8) at the start of every preparation.
This will allow you to check that everything is working correctly.

See table below for visual instructions. (p.09)

1. Prepare your material. Install the plates in this order: Bottom Plate, Filling Plate, Top Plate. Be careful to orient the Bottom and Filling plates with the notches forward.
2. Load the Capsules. You can place them by hand or with a Feton capsule Loader. (or FetonCards).
3. Pull the Lever to lock the Capsules' bodies.
4. Pull the Top Plate upwards, starting from the back side for easier separation. Push with your thumbs on the Filling Plate in the back corners and pull with the fingers on the Top Plate.
5. Release the Lever. If needed, push on the Capsules's bodies so that they are flush with the Filling Plate.
Fill the Capsules. Use a tamper if needed.
6. Place the Top Plate. Pull the Base Plate to push the Capsules' bodies into the Capsules' heads. The capsules are now "pre-closed".
7. Take the Top Plate and turn it upside down on your table. If you have a Serial Closer, use it to close the Capsules in one smooth motion. If you do not have a Serial Closer, close the capsules by hand.
8. Your Capsules are now ready.

1

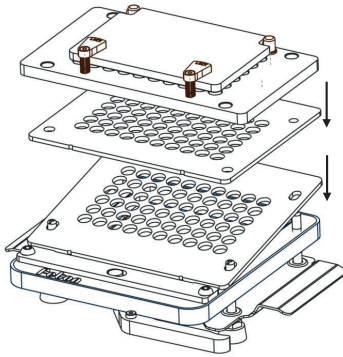

2

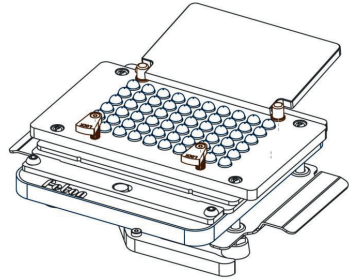

3

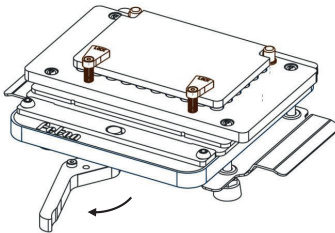

4

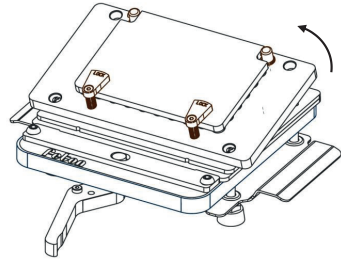

5

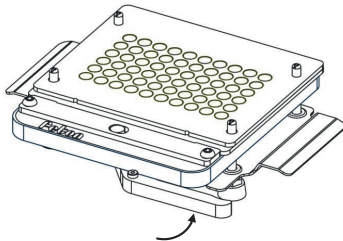

6

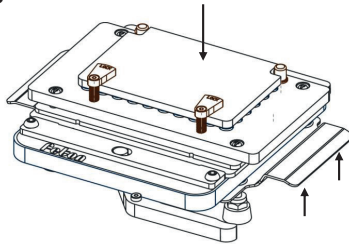

7

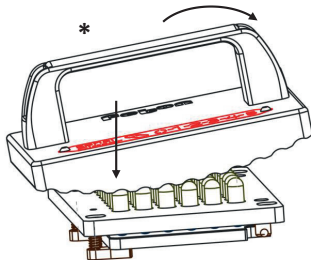

8

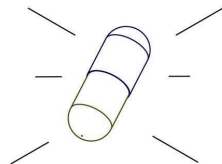

* Optional accessory : Serial Closer : REF : SECL-0/1/2/3/4/5 or SECL-000/00

OPTIONAL : Capsule Loader available :

- Manufactured in certified plastic (POM).
- Frame made in one piece.
- Easier removal of excess capsules.
- Machine washable up to 40°C.

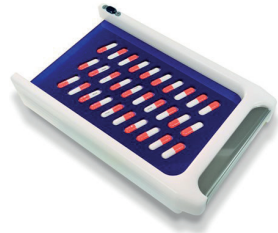

REF. CH60

5 HOW TO CLEAN

It is important to clean the parts in contact with the capsules or the powder thoroughly between each use to avoid contamination. Cleaning can be done by hand, in a dishwasher or in an autoclave. If done by hand, use warm water and soap.

Use a maximum temperature of 110°C / 230°F for all the metallic parts.

Use a maximum temperature of 40°C / 104°F for all the plastic parts.

If you have difficulties cleaning the inside of holes on the plates, use the small Feton-cleaning brush :



REF. BRU

