

Class 250 Iron Body Gate Valves

Bolted Bonnet • Outside Screw and Yoke • Solid Wedge • Bronze Mounted

500 PSI/34.5 bar non-shock cold working pressure to -20°F to 150°F/-29°C to 66°C*
Maximum working temperature 450°F/232°C at 250 PSI/17.2 bar
250 PSI/17.2 bar saturated steam to 406°F/208°C

CONFORMS TO MSS SP-70 • APPROVED BY THE
NEW YORK CITY B.S.A. 143-69-SA AT 350 PSI
NON-SHOCK COLD WATER

MATERIAL LIST

PART	SPECIFICATION
1. Stem	Copper Alloy, ASTM B16 C36000
2. Nut, Handwheel	Cast Copper Alloy, ASTM B584 C84400
3. Nameplate, I.D.	Aluminum
4. Handwheel, Blue	Cast Iron, ASTM A126-B
5. Bushing, Yoke	Cast Copper Alloy, ASTM B584 C84400
6. Screw, Hex - Bonnet Cap	Steel, ASTM A307 / SAE J429
7. Cap, Bonnet	Ductile Iron, ASTM A536
8. Nut, Square - Bonnet Cap	Steel, ASTM A563
9. Bonnet	Cast Iron, ASTM A126-B
10. Nut, Heavy Hex - GLD Follow	Steel, ASTM A563
11. Gland Follower	Ductile Iron, ASTM A536
12. Pack Gland	Powdered Metal, ASTM B783
13. Pack Ring	Aramid Fibers / Graphite
14. Bolt, SQ Head - GLD Follow	Steel, ASTM A307 / SAE J429
15. Screw, Hex - Body	Steel, ASTM A307 / SAE J429
16. Gasket, Body	Reinforced Flexible Graphite
17. Nut, Hex - Body	Steel, ASTM A563
18. Collar, Stem	Copper Alloy, ASTM B16 C36000
19. Wedge Nut	Cast Copper Alloy, ASTM B584 C84400
20. Wedge Seat Ring	Cast Copper Alloy, ASTM B584 C84400
21. Wedge Pin	Copper Alloy, ASTM B140 C31600
22. Wedge	Cast Iron, ASTM A126-B
23. Body Seat Ring	Cast Copper Alloy, ASTM B584 C84400
24. Body	Cast Iron, ASTM A126-B

¹ Sizes thru 6", Yoke and Bonnet are integral. 8" and 12" sizes separate Yoke is bolted to Bonnet.

² Sizes 2" thru 3" have Cast Copper Alloy Wedges. Sizes 4" thru 12" made with Cast Iron Wedge with Cast Copper Alloy Face Rings.

³ Cast Copper Wedge Nuts used on Sizes 5" thru 12".

⁴ 2" to 8" have Aramid Fibers with Graphite packings. 10" & 12" have wire reinforced carbon yarn with resilient core and graphite and Zinc finish.

DIMENSIONS—WEIGHTS—QUANTITIES

Size	Dimensions						Weight						
	A	B	C	D	E	Lbs.	Kg.						
In. mm.	In. mm.	In. mm.	In. mm.	In. mm.	In. mm.								
2	50	8.50	216	16.06	408	8.00	203	6.50	165	0.87	22	56	25
2½	65	9.50	241	18.31	465	8.00	203	7.50	191	1.00	25	74	34
3	80	11.12	282	21.46	545	10.25	260	8.25	210	1.12	28	122	55
4	100	12.00	305	23.53	598	10.25	260	10.00	254	1.25	32	193	88
5	125	15.00	381	29.74	755	14.00	356	11.00	279	1.37	35	297	135
6	150	15.87	403	33.11	841	16.25	413	12.50	318	1.44	37	411	187
8	200	16.50	419	45.84	1164	16.25	413	15.00	381	1.62	41	637	290
10	250	18.00	457	54.43	1383	20.00	508	17.50	445	1.87	47	897	408
12	300	19.75	502	57.96	1472	20.00	508	20.50	521	2.00	51	1172	533

FREEZING WEATHER PRECAUTION: Subsequent to testing a piping system, valves should be left in an open position to allow complete drainage.

◆ For detailed Operating Pressure, refer to Pressure Temperature Chart on page 116.

Visit our website for the most current information.



F-667-O
Flanged

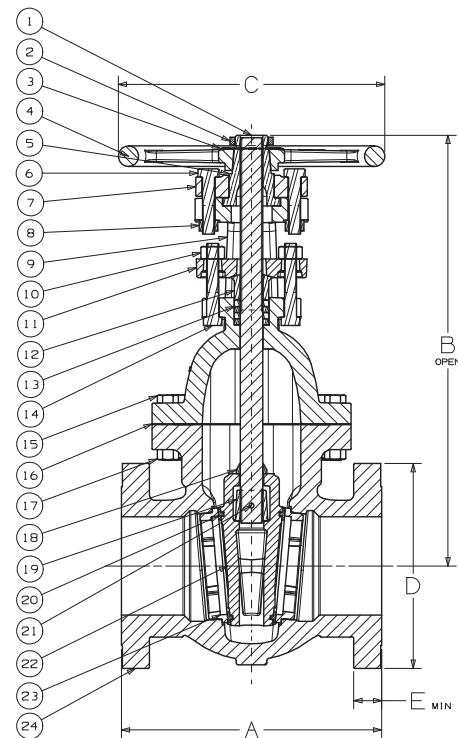

F-667-O
Flg x Flg

NOTE: NIBCO may substitute Ductile Iron ASTM A395 (60-40-18) for ASTM A126 Class B Cast Iron for the Body, Bonnet, Wedge, or Disc. NIBCO may substitute Ductile Iron ASTM A395 (60-40-18) or ASTM A536 (65-45-12) for all other ASTM A126 Class B Cast Iron components.



WARNING: This product can expose you to chemicals including lead, which is known to the State of California to cause cancer and birth defects or other reproductive harm. For more information go to www.P65Warnings.ca.gov.