

NIBCO® Press System Lead-Free Brass Ball Valves

Features: Press End Leak Detection • PEX end F1960 Cold Expansion • Two-Piece Body • PTFE Seats • Blowout-Proof Stem • Double Stem Seal

Approvals: MSS SP-110/145 • IAPMO/ANSI Z1157 • NSF/ANSI 14 61/372 • Conforms to ASME B16.51†

Size range: 1/2" - 2"

Pressure rating: 250 PSI non-shock cold working pressure

Maximum pressure / temperature: 225 PSI at 250° F

Lead-free markings: White handle and blue hang tag

Applications: Drinking Water • Domestic Hot & Cold Water • HVAC (condensors, chilled water, hot water heating) • Isolation and Throttling (half-open to full-open only) • Connect to Rigid Copper Tubing Manufactured per ASTM B88, Condition H (hard drawn)

Reference Press System catalog for updated Approved Tool and Jaw Compatibility Matrix list.

Not intended for steam or gas usage.

MATERIAL LIST

PART	SPECIFICATION
1. Body	Forged DZR Copper Alloy - C46500
2. Seat Seal (2)	PTFE
3. O-ring	EPDM - ASTM D2000
4. Packing	PTFE
5. Washer	Stainless Steel ASTM 321
6. Lock Nut	Stainless Steel 304
7. Handle	Steel, Plated
8. Nut	Brass
9. Stem	Brass
10. Ball	Chrome Plated Brass - C46500 (1/2"-1") Stainless Steel 316 (1 1/4"-2")
11. End Cap	Forged DZR Copper Alloy - C46500 (F1960 Cold Expansion)
12. O-ring	EPDM - ASTM D2000 (Leak Detect)
13. Metal Ring	Stainless Steel (1 1/4"-2")**

Options:

- Extended lever
- EPDM Seal for Press Ends
- Wing Handle



Handle Markings

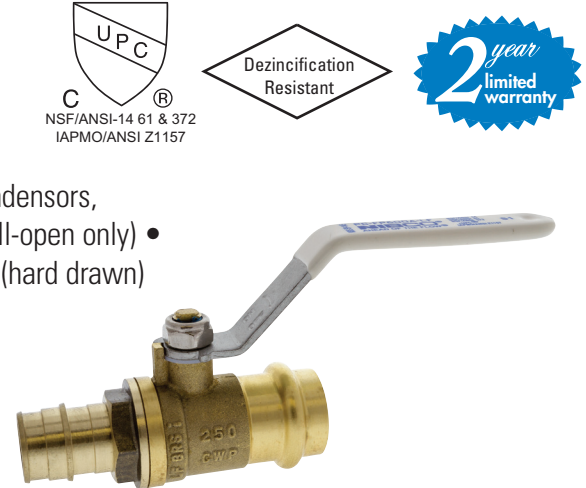

PCPXA-FP-600A-LF

Press x PEX (F1960 - Cold Expansion)

1/2" - 2"

Patent Pending sizes 1 1/4" - 2"

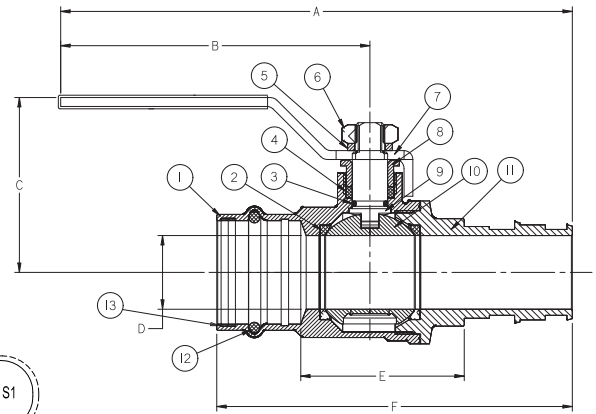

PCPXA-FP-600A-LF

Press x PEX (F1960 - Cold Expansion)

1/2" - 2" **

DIMENSIONS—WEIGHTS—QUANTITIES

SIZE	A		B		C		D		E		F		Weight	
In.	In.	mm.	In.	mm.	In.	mm.	In.	mm.	In.	mm.	In.	mm.	Lbs.	Kg.
1/2"	5.15	130.90	3.62	92.00	1.20	30.55	0.39	10.00	1.30	32.90	2.79	70.90	0.3400	0.1542
3/4"	5.48	139.20	3.62	92.00	1.34	34.00	0.60	15.30	1.48	37.70	3.33	84.70	0.5090	0.2308
1"	6.37	161.70	4.13	105.00	2.06	52.20	0.79	20.00	1.74	44.20	3.83	97.20	0.8620	0.3909
1 1/4"	7.09	180.00	4.37	111.00	2.58	65.5	0.98	25.00	2.19	55.50	4.75	120.70	1.5400	0.6900
1 1/2"	8.31	211.00	5.04	128.00	2.70	68.5	1.09	27.80	2.63	66.85	5.72	145.40	2.3300	1.0600
2"	10.19	258.80	6.22	158.00	3.16	80.2	1.57	40.00	3.12	79.20	6.92	175.70	3.6600	1.6600

IAPMO/ANSI Z1157: in addition to meeting ICG-157 test requirements, the IAPMO/ANSI Z1157 also requires Press ends to be fully tested to IAPMO PS-117 performance requirements which includes the following additional tests:

†Tested to the performance criteria of ASME B16.51

**Patent Pending

- | | | | |
|------------------------------------------------------------|----------------------------------------|-------------------------|------------------------------------------------|
| 1. Unrestrained Hydrostatic Pressure Test at 20 °C (68°F) | 4. Bending Test | 7. Vibration Test | 9. Alternate Thermal Cycling Test |
| 2. Unrestrained Hydrostatic Pressure Test at 93 °C (200°F) | 5. Vacuum Test | 8. Thermal Cycling Test | 10. Dynamic Torsion Test for Press Connections |
| 3. Static Torsion Test for Press Connections | 6. Hydraulic Shock (Water Hammer) Test | | |

WARNING: This product can expose you to chemicals including lead, which is known to the State of California to cause cancer and birth defects or other reproductive harm. For more information go to www.P65Warnings.ca.gov.

LEAD-FREE: Weighted average lead content ≤ 0.25%