

Class 150 Bronze Gate Valves

Bolted Bonnet • Non-Rising Stem • Split Wedge

150 PSI/10.3 bar saturated steam to 366°F/185°C
300 PSI/20.7 bar non-shock cold working pressure

CONFORMS TO MSS SP-80

MATERIAL LIST

PART	SPECIFICATION
1. Handwheel Nut	300 Series Stainless Steel
2. Identification Plate	Aluminum
3. Handwheel	Aluminum Commercial Alloy 380
4. Stem	Silicon Bronze ASTM B 371 Alloy C69400/C69430
5. Packing Nut	Bronze ASTM B 62 or ASTM B124 Alloy C36000 or Brass ASTM B16
6. Packing Gland	Bronze ASTM B 62 or ASTM B584 Brass ASTM B16 C36000
7. Packing	Aramid Fibers with Graphite
8. Stuffing Box	Bronze ASTM B 62
9. Bonnet	Bronze ASTM B 62
10. Bonnet Bolt	Zinc Plated Steel
11. Bonnet Gasket	Aramid Fibers with Graphite
12. Body	Bronze ASTM B 62
13. Wedge	Bronze ASTM B 62
14. Wedge Holder	Bronze ASTM B 62

DIMENSIONS—WEIGHTS—QUANTITIES

Size	Dimensions						T-136		S-136		Master Ctn. Qty.	
	A		B		C		Lbs.	Kg.	Lbs.	Kg.		
In.	mm.	In.	mm.	In.	mm.	In.	mm.	Lbs.	Kg.	Lbs.	Kg.	
4	100	6.44	164	12.25	311	3.56	90	43.85	19.89	42.13	19.13	1

NOTE: Split wedge with wedge holder.

FREEZING WEATHER PRECAUTION: Subsequent to testing a piping system, valves should be left in an open position to allow complete drainage.

◆ For detailed Operating Pressure, refer to Pressure Temperature Chart on page 116.

WARNING: This product can expose you to chemicals including lead, which is known to the State of California to cause cancer and birth defects or other reproductive harm. For more information go to www.P65Warnings.ca.gov.

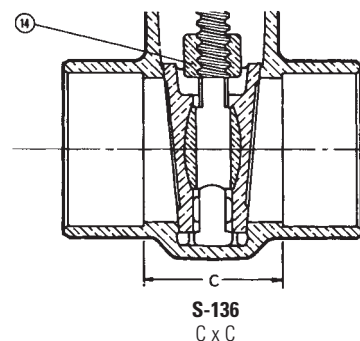
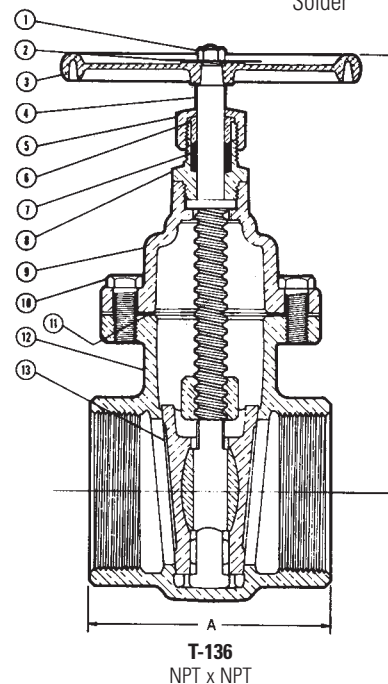
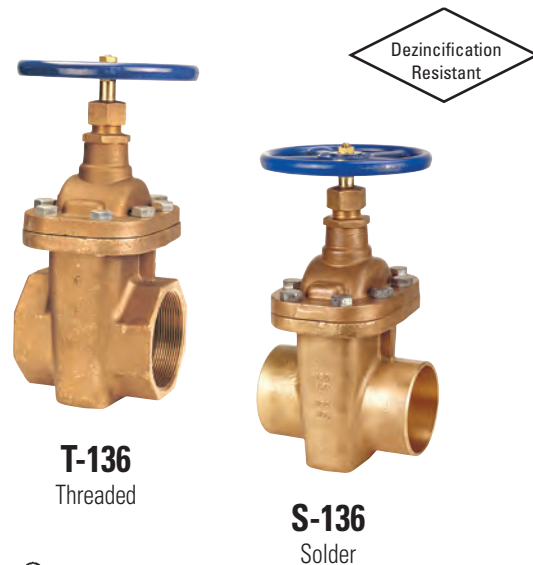

Visit our website for the most current information.