

1805-LF Lead-Free NSF/ANSI 61 & 372* DZR Brass Fixed Orifice Circuit Balancing Valve - 1/2" to 2"

**Model: MTPC-1805-LF20, MTPC-1805R-LF20, MTPC-1805-LF66 & MTPC-1805R-LF66
TPC-1805-LF20, TPC-1805R-LF20, TPC-1805-LF66 & TPC-1805R-LF66
SPC-1805-LF20, SPC-1805R-LF20, SPC-1805-LF66 & SPC-1805R-LF66**

MATERIAL LIST	
PART	SPECIFICATION
Body	Brass - UNS C46500 (DZR)
End Connector	Brass - UNS C46500 (DZR)
Ball valve seats	PTFE
Ball	Stainless Steel - UNS S30400
Stem - 1/2" to 1" - LF20	Brass - UNS C46500 (DZR)
Stem - 1/2" to 1" - LF66	Stainless Steel - UNS S30400
Stem - 1 1/4" to 2" - LF66	Stainless Steel - UNS S30400
O-rings	EPDM
Lever	Steel - Zinc Plated
Washer head screws	Stainless Steel - UNS S30400
Memory stop	Steel - Zinc Plated
Union nut	Brass - CW617N
Plug	Brass - UNS S46500 (DZR)
Venturi	Brass - UNS S46500 (DZR)
Test Point (2)	Brass - CZ132A (DZR)
Press End	Copper - ASTM B75 C12200
Press End O-ring	EPDM

RECOMMENDED FLOW RANGE			
		Flow Range - gpm	
Size - In.	Venturi No.	Min	Max
1/2" & 3/4"	V-1	0.24	2.0
1/2" & 3/4"	V-2	0.8	6.0
3/4" & 1"	V-3	1.0	8.0
3/4" & 1"	V-4	2.3	18.0
1"	V-5	2.2	18.0
1 1/4"	V-6	4.3	35.0
1 1/2"	V-7	4.8	50.0
2"	V-8	6.0	80.0



*Weighted average lead content ≤0.25%

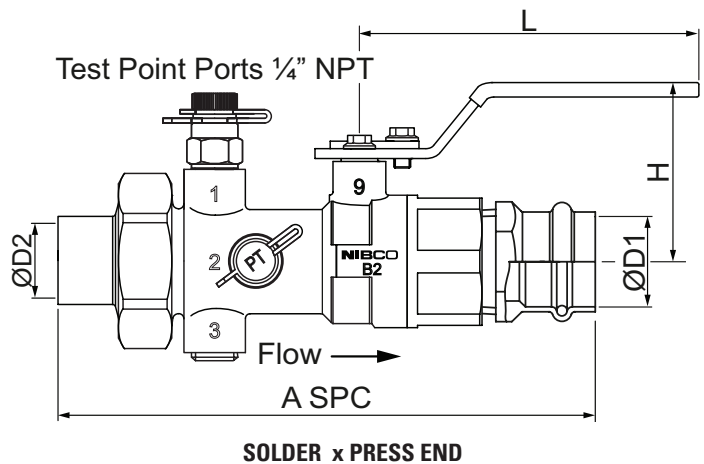
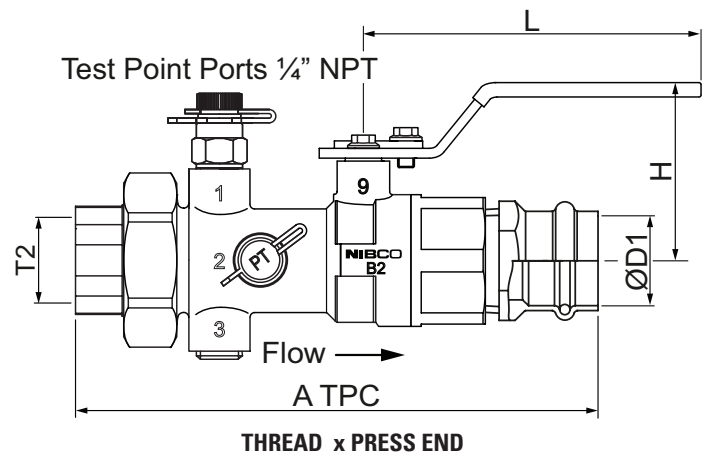
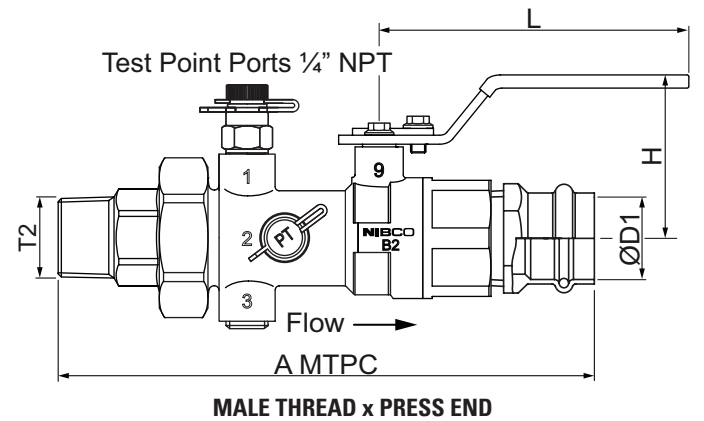

1805-LF Lead-Free NSF/ANSI 61 & 372* DZR Brass Fixed Orifice Circuit Balancing Valve - 1/2" to 2"

**Model: MTPC-1805-LF20, MTPC-1805R-LF20, MTPC-1805-LF66 & MTPC-1805R-LF66
TPC-1805-LF20, TPC-1805R-LF20, TPC-1805-LF66 & TPC-1805R-LF66
SPC-1805-LF20, SPC-1805R-LF20, SPC-1805-LF66 & SPC-1805R-LF66**

DIMENSIONS - In.											
						Male Thread		Thread		SOLDER	
Body	T2 - Thread	D1	D2	H	L	A MTPC	Weight Lbs	A TPC	Weight Lbs	A SPC	Weight Lbs.
B1	1/2" - 14 NPT	0.63	0.63	2.01	3.98	6.04	1.49	5.37	1.42	5.36	1.42
B1	3/4" - 14 NPT	0.88	0.88	2.01	3.98	6.59	2.06	6.56	1.97	6.03	1.83
B1	1/2" - 14 NPT	0.88	0.63	2.10	3.98	6.54	2.02	6.09	1.88	5.87	1.96
B2	1/2" - 14 NPT	0.88	0.63	2.01	3.98	6.80	2.02	5.87	1.96	5.66	1.96
B2	1/2" - 14 NPT	1.13	0.63	2.07	3.98	6.93	2.49	6.26	2.36	5.79	2.36
B2	3/4" - 14 NPT	1.13	0.88	2.07	3.98	6.93	2.53	6.26	2.37	5.56	2.37
B3	1" - 11.5 NPT	1.13	1.13	2.24	5.34	7.48	2.60	7.43	2.60	6.72	2.60
B3	1/2" - 14 NPT	1.13	0.63	2.24	5.34	7.22	2.49	6.55	2.36	6.60	2.36
B3	3/4" - 14 NPT	1.13	0.88	2.24	5.34	7.28	2.53	6.55	2.37	6.70	2.37
B4	1 1/4" - 11.5 NPT	1.38	1.38	2.43	5.34	9.19	5.07	8.39	4.90	8.82	5.13
B4	3/4" - 14 NPT	1.38	0.88	2.43	5.34	9.19	4.93	8.18	4.77	8.65	4.45
B4	1" - 11.5 NPT	1.38	1.13	2.43	5.34	9.19	4.91	8.38	4.82	8.78	4.44
B5	1 1/2" - 11.5 NPT	1.63	1.63	2.87	5.94	10.2	6.82	10.57	7.80	9.55	8.03
B5	1" - 11.5 NPT	1.63	1.13	2.87	5.94	10.2	6.64	9.36	6.32	9.79	6.34
B5	1 1/4" - 11.5 NPT	1.63	1.38	2.87	5.94	10.2	6.80	9.38	6.40	9.81	6.52
B6	2" - 11.5 NPT	2.13	2.13	3.11	5.94	11.4	10.23	11.8	11.6	10.9	10.8
B6	1 1/4" - 11.5 NPT	2.13	1.38	3.11	5.94	11.4	10.09	11.4	9.82	10.9	9.52
B6	1 1/2" - 11.5 NPT	2.13	1.63	3.11	5.94	11.4	10.23	11.4	10.0	11.0	9.63

Threaded & Solder

Maximum Working Pressure 600 PSI @ 100°F

Maximum Temperature 250°F @ 150 PSI

Press End

Maximum Working Pressure 200 PSI @ 230°F

Maximum Temperature 250°F @ 150 PSI

Flow Measurement Accuracy

Reference Figure 1805 Series Flow Rate Brochure for specific information regarding flow and accuracy characteristics.

Project: _____

Contractor: _____

PO/Job No.: _____

Engineer: _____

Representative: _____

Date: _____