

5th Edition

GAS PRESSURE REGULATOR CATALOG



MAXITROL®

▲ WARNING

Service and installation must be performed by a trained/experienced service technician.

All products used with combustible gas **must** be installed and used **strictly** in accordance with the instructions of the Original Equipment Manufacturer (OEM) and with all applicable government codes and regulations, e.g. plumbing, mechanical, and electrical codes and practices. Maxitrol products should be installed and operated in accordance with Maxitrol Safety Warning Instructions.

Maxitrol Company is NOT responsible for any errors or omissions in reliance by anyone of any information set forth in this catalog without additional reference to local requirements and applicable ordinances or codes.

Other worldwide approvals and certifications available upon inquiry.



SR SERIES

2 Stage Design

An ideal replacement for dual manifold systems, the SR series combines gas pressure regulating and flame staging in a single unit. Applications include direct-fired heaters with two speed fans, hi-lo control for outdoor heaters, LP natural gas switchover and industrial processing.



SR400

Specifications

Pipe Sizes 3/8" thru 1" threaded connections with NPT or ISO7-1 threads.

Housing Material SR400, SR500, SR600: aluminum.

Mounting Mount in an upright position only.

NOTE: All Maxitrol gas pressure regulators should be installed and operated in accordance with Maxitrol Safety Warning Instructions (see SELMMRSR_MI_EN.FR.ES).

Certifications SR400, SR500, SR600: ANSI Z21.18/CSA 6.3 Gas Appliance Pressure Regulators (except suffix -2 models).

Gas Types Suitable for natural, manufactured, mixed gases, liquefied petroleum gases, and LP gas-air mixtures.

Rated Inlet Pressure CSA Certified: 1/2 psi (3.4 kPa)

Maxitrol Tested 1 psi (6.9 kPa)

Flow Rates..... up to 1,000 CFH (28.32 m³/h)

Emergency Exposure Limits..... 2.5 psi (17.2 kPa)

Ambient Temperature Ranges..... -40 to 175°F (-40 to 79°C)

Minimum Regulation..... SR400, SR500: 5 CFH; SR600: 60 CFH

NOTE: SR400-2, SR500-2, SR600-2 models are designed primarily for LP gas applications.

NOTE: All models may be powered by a 24 volt AC transformer. When the coil is energized, the appliance is at low fire. When the coil is de-energized, it is high fire. Continuous regulation is maintained to hold the electrically set outlet pressure constant.

NOTE: Suffix "W" refers to an aluminum terminal enclosure.



Capacities and Pressure Drop: inches w.c. (kPa)

Model Number	Pipe Size	Flow Rate - CFH (m³/h)								
		CSA MAX	100 (2.83)	200 (5.66)	300 (8.50)	400 (11.33)	500 (14.16)	600 (16.99)	750 (21.24)	1000 (28.32)
SR400	3/8" x 3/8"	150 (4.02)	0.33 (0.08)	1.30 (0.32)	---	---	---	---	---	---
	1/2" x 1/2"	170 (4.8)	0.27 (0.07)	1.10 (0.27)	---	---	---	---	---	---
SR500	1/2" x 1/2"	360 (10.2)	0.08 (0.02)	0.30 (0.08)	0.68 (0.17)	1.20 (0.30)	---	---	---	---
	3/4" x 3/4"	400 (11.2)	0.05 (0.01)	0.21 (0.05)	0.47 (0.12)	0.83 (0.20)	1.30 (0.32)	---	---	---
SR600	3/4" x 3/4"	600 (16.8)	---	0.09 (0.02)	0.20 (0.05)	0.36 (0.09)	0.56 (0.14)	0.81 (0.20)	1.25 (0.31)	---
	1" x 1"	600 (16.8)	---	0.07 (0.02)	0.16 (0.04)	0.29 (0.07)	0.45 (0.11)	0.66 (0.16)	1.00 (0.25)	1.75 (0.44)

NOTE: Capacities expressed in CFH (m³/h) @ 0.64 sp gr gas

CSA maximum capacities vary with spring range and pipe size. Please contact Maxitrol directly for CSA maximums. See pages 58-59 for Regulator Sizing Requirements and Examples.

Spring Selection: inches w.c. (kPa)

Model	Available Springs					
SR400 (-1)	Maximum	3 to 5 (0.75 to 1.25) S. Steel	2.5 to 3.5 (0.62 to 0.87) White	4 to 6 (1 to 1.5) S. Steel	3 to 5 (0.75 to 1.25) White	---
	Minimum	0.3 to 1.2 (0.07 to 0.3) Plated	0.3 to 1.2 (0.07 to 0.3) Plated	1 to 2.8 (0.25 to 0.7) Blue	1 to 2.8 (0.25 to 0.7) Blue	2.5 to 4 (0.62 to 1) Black
SR400-2*	Maximum	7.5 to 12 (1.87 to 3) - Blue				
SR500 (-1)	Maximum	3 to 5 (0.75 to 1.25) S. Steel	1.5 to 3.5 (0.37 to 0.87) White	3.5 to 6 (0.87 to 1.5) S. Steel	2 to 4.5 (0.5 to 1.12) White	---
	Minimum	0.3 to 1.2 (0.07 to 0.3) Plated	0.3 to 1.2 (0.07 to 0.3) Plated	1 to 2.8 (0.25 to 0.07) Blue	1 to 2.8 (0.25 to 0.7) Blue	2.5 to 4 (0.62 to 1) Black
SR500-2*	Maximum	7.5 to 12 (1.87 to 3) - Blue				
SR600 (-1)	Maximum	3 to 5 (0.75 to 1.25) S. Steel	2.5 to 4 (0.62 to 1) White	4 to 6 (1 to 1.5) S. Steel	3 to 5.5 (0.75 to 1.37) White	---
	Minimum	0.5 to 1.2 (0.12 to 0.3) Plated	0.5 to 1.2 (0.07 to 0.3) Plated	1 to 2.8 (0.25 to 0.7) Blue	1 to 2.8 (0.25 to 0.7) Blue	2.5 to 4 (0.62 to 1) Black
SR600-2*	Maximum	7.5 to 12 (1.87 to 3) - Blue				

* For LP application - may be used with any minimum spring.

NOTE: See pages 56-57 for complete Spring Selection Chart.

SR SERIES

2 Stage Design

Dimensions

Model	Pipe Size	Vent Connection	Dimensions			
			A	B	C	D
SR400	3/8", 1/2"	1/8" NPT, 12A06 vent limiting device installed.	4" (102 mm)	1" (25 mm)	2.2" (56 mm)	2" (51 mm)
SR500	1/2", 3/4"	1/8" NPT, 12A06 vent limiting device installed.	5.3" (135 mm)	1.2" (30 mm)	3.4" (86 mm)	3.2" (81 mm)
SR600	3/4", 1"	1/8" NPT, 12A06 vent limiting device installed.	7" (178 mm)	1.5" (38 mm)	4" (102 mm)	3.9" (99 mm)

NOTE: Dimensions are maximums and to be used only as an aid in designing clearance for the valve. Actual production dimensions may vary somewhat from those shown.

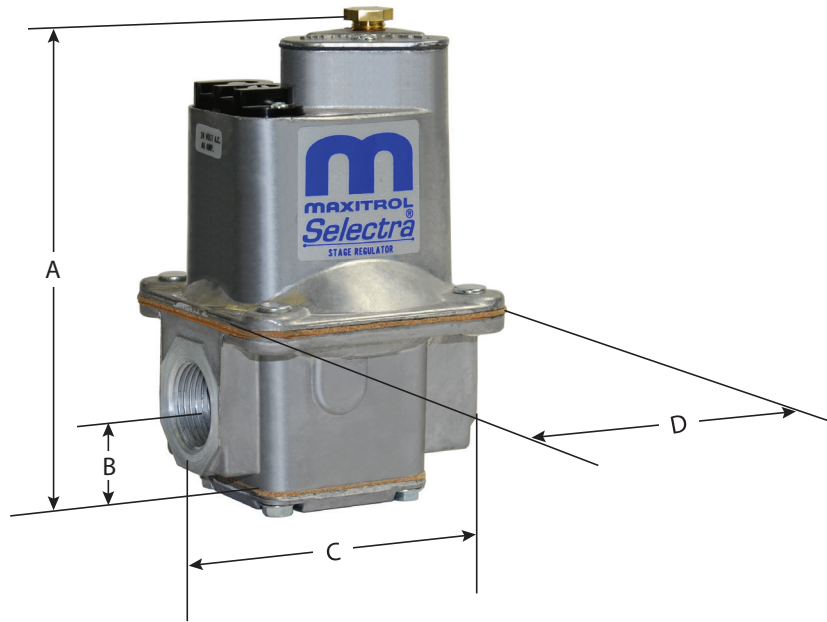

SR400, SR500, SR600

2 Stage Design

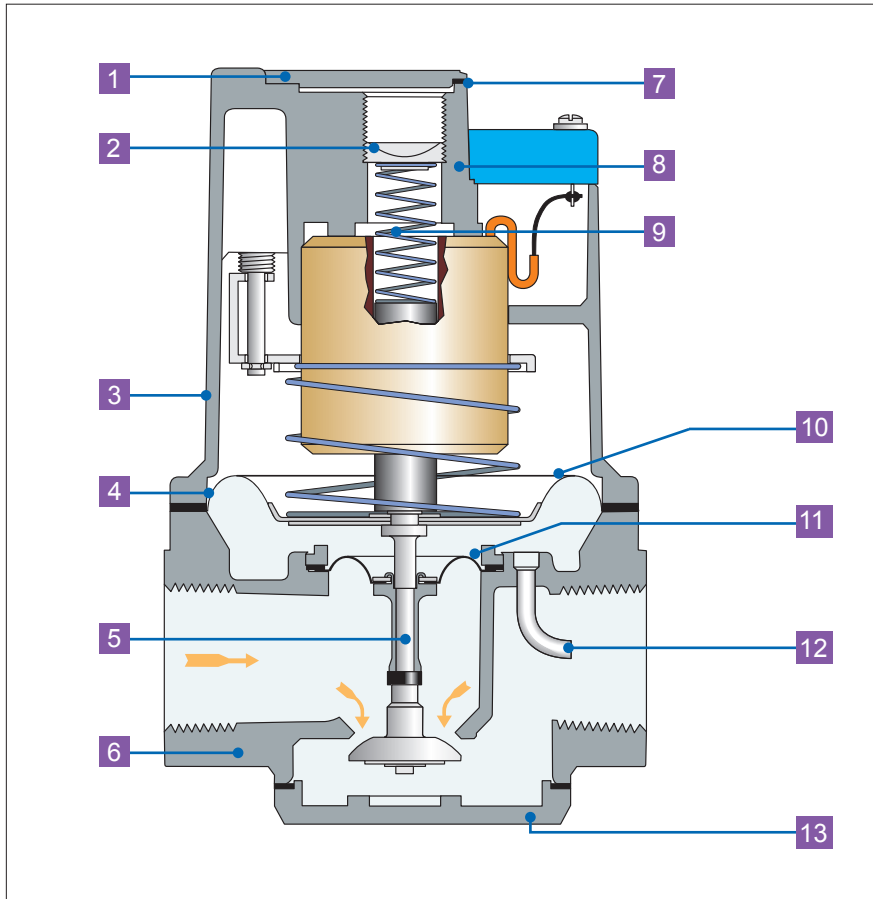

- 1 Seal Cap
- 2 Adjusting Screw
- 3 Top Housing
- 4 Regulating Diaphragm
- 5 Stem & Valve
- 6 Bottom Housing
- 7 Seal Cap Gasket
- 8 Stack
- 9 Spring
- 10 Diaphragm Plates
- 11 Balancing Diaphragm
- 12 Sensing Tube
- 13 Bottom Plate

NOTE: Diagrams are graphical representations only and may differ from actual product.

SIZING A REGULATOR

See www.maxitrol.com for our Regulator Sizing Program. Please contact Maxitrol directly for more information on sizing a regulator.

System Requirements

When sizing a regulator the following must be known:

- Gas Type
- Available Inlet Pressure
- Desired Outlet Pressure
- Zero Governor Application (indicated by model number ending in "Z")
- Will the regulator control main burner and pilot load OR main burner only?
- Required minimum and maximum flow rate in cfh or m³/h or Btu/h
- Pipe Size

In most cases, the manifold pipe size has already been selected on the basis of good engineering practice, and the regulator pipe size should conform to this size.

The capacity of any regulator is not an absolute value but will vary with the application depending on the prevailing differential pressure.

▲ WARNING

Service and installation must be performed by a trained/experienced service technician.

All products used with combustible gas must be installed and used strictly in accordance with the instructions of the Original Equipment Manufacturer (OEM) and with all applicable government codes and regulations, e.g. plumbing, mechanical, and electrical codes and practices. These instructions do NOT supersede OEM's installation or operating instructions.

All Maxitrol products should be installed and operated in accordance with Maxitrol Safety Warning Instructions.

HOW TO CALCULATE PRESSURE DROP AT VARIOUS FLOW RATES FROM CAPACITY CHART

LP Applications - When using natural gas pressure drop chart to determine LP pressure drop in terms of Btu/h, multiply NAT Btu/h by 1.61; in terms of CFH multiply NAT CFH by 0.645.

$$\text{Formula: } P_2 = P_1 \times (Q_2/Q_1)^2$$

P₂ = Pressure drop at desired flow rate

P₁ = Known pressure drop

Q₂ = Desired flow rate

Q₁ = Known flow rate

A. Check Capacity Chart, ensuring regulator has ample range of regulation and individual load capacities (for use with pilot) for the application.

B. Know the minimum encountered inlet pressure. MINIMUM INLET PRESSURE MINUS "P₂" MUST BE GREATER THAN DESIRED OUTLET PRESSURE. Solve for "P₂" using the formula above. (See examples on page 59.)

Sizing Examples

RUBBER SEAT POPPETS

For main burner and pilot load applications.

Example: To select an RV type regulator:

- Known: Single 150,000 Btu/h main burner; pipe size 1/2"; inlet pressure 7" w.c.; outlet pressure 4" w.c.
- Solution: The RV48 (1/2") has a maximum capacity of 230,000 Btu/h and a maximum individual load of 160,000 Btu/h. The pressure drop at a flow rate of 150,000 Btu/h is 0.4" w.c., well below the available differential of 3" w.c. The RV48 (without "L" fixed orifice) is the correct regulator to use for the application.

STRAIGHT-THRU-FLOW (S-T-F)

For main burner only applications not requiring a lockup type regulator. When sizing the S-T-F series, it is recommended that pressure drop not exceed 1/2 of available differential pressure.

Example: To select an RV type regulator:

- Known: Flow rate 2,000,000 Btu/h; pipe size 1 1/4"; inlet pressure 9" w.c.; outlet pressure 5" w.c.
- Solution: The RV81(1 1/4") has a maximum capacity of 2,500,000 Btu/h. The pressure drop at a flow of 2,000,000 Btu/h is 0.66" w.c. The RV81 (1 1/4") is the correct regulator to use with this application. The pressure drop of the RV61 (1 1/4") at a flow rate of 2,000,000 Btu/h is 2.64" w.c. This is within the available differential but exceeds the recommended 50% maximum.

LEVER ACTING

For main burner and pilot load application requiring positive dead-end lockup (see Definitions page 63).

Example: To select a 325 series regulator:

- Known: Single 145,000 Btu/h burner; pipe size 1/2"; inlet pressure 2 psi; outlet pressure 7" w.c.
- Solution: The 325-3's pressure drop at a flow rate of 145,000 Btu/h is 7" w.c., well below the available differential of 1 3/4 psi. However, the Maximum Individual Load for the 325-3 is only 100,000 Btu/h. The 325-5 (1/2") is the correct regulator to use with this application.

BALANCED VALVE

For main burner and pilot load application requiring a lockup type regulator or zero governor usage (see Definitions page 63).

Example: To select a 210 or R/RS series regulator:

- Known: Desired flow rate 6,000,000 Btu/h; pipe size 1 1/2"; inlet pressure 1 psi; outlet pressure 9" w.c.
- Solution: The 210E (1 1/2") has a maximum capacity of 10,000,000 Btu/h. The 210D (1 1/2") has a capacity of 6,000,000 Btu/h. Therefore, the 210E (1 1/2") will give you the desired outlet pressure of 9" w.c. and is the correct regulator to use for the application.

North America

Maxitrol Company, Inc.
23555 Telegraph Rd., PO Box 2230
Southfield, MI 48037-2230
USA
Tel: +1 248-356-1400
Fax: +1 248-356-0829

Europe

Maxitrol GmbH & Co. KG
Warnstedter Str. 3
06502 Thale
Germany
Tel: + 49 3947 400-0
Fax: + 49 3947 400-200

www.maxitrol.com