



PL-FC3318DB

Farmhouse Series
Fireclay Sink

Features

- Double Bowl
- Reversible Front Design
- Nonporous Gloss - Hygienic

Material

- Clay and Various Minerals

Installation

- Apron Front, Undermount



6140 Ulmerton Road Clearwater, FL 33760

Phone: (727) 388-9895

Fax: (727) 362-1281

For the most current Specification Sheet, go to www.pelicansinks.com





PL-FC3318DB

Farmhouse Series
Fireclay Sink

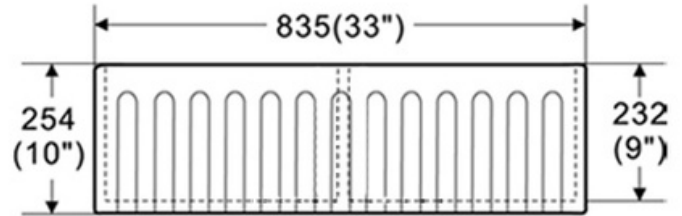
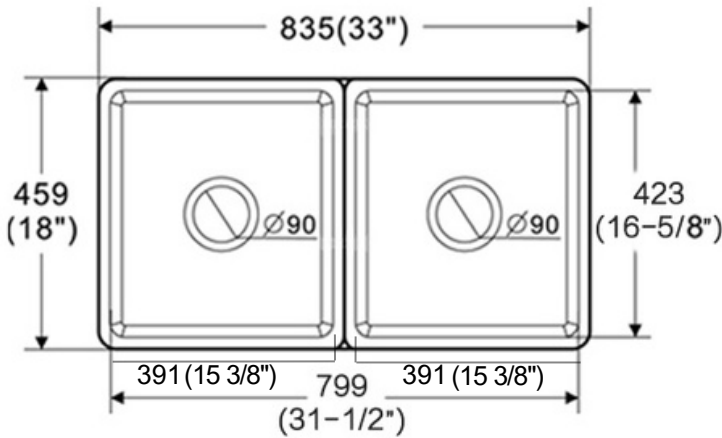

fluted

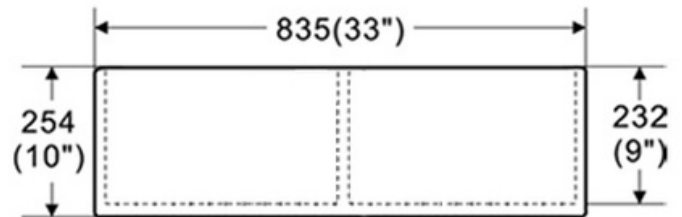

plain

Technical Information

All product dimensions are nominal

Exterior Measurements: 33" x 18" x 10"

Bowl Measurements: 15 3/8" x 16 5/8" x 9"

Bowl Configuration: Double

Installation Information

Install this product according to the installation instructions.

Limited Lifetime Warranty

See website for detailed warranty information.

6140 Ulmerton Road Clearwater, FL 33760

Phone: (727) 388-9895

Fax: (727) 362-1281

For the most current Specification Sheet, go to www.pelicansinks.com

